

NOTES

FOAM JOINTS SHALL BE INSTALLED AS PER MANUFACTURER'S RECOMMENDATIONS.

FOR FOAM JOINT SEALS FOR PRESERVATION, SEE SPECIAL PROVISIONS.

FOR BRIDGE JOINT DEMOLITION, SEE SPECIAL PROVISIONS.

THE INSTALLED FOAM JOINTS SHALL BE WATER TIGHT.

THE FOAM JOINTS SHALL MEET THE MANUFACTURER'S RECOMMENDATION FOR THE SIZE OF OPENING ON THE PLANS, AND ACCOMMODATE THE MINIMUM EXPANSION SHOWN ON THE PLANS.

THE CONTRACTOR WILL NOT BE PERMITTED TO FORM THE JOINTS IN LIEU OF SAWING THE JOINT.

THE MANUFACTURER IS TO PROVIDE THE NOMINAL UNCOMPRESSED SEAL WIDTH OF THE FOAM JOINT SEAL BASED ON JOINT OPENINGS AT THE END BENTS 1 AND 2.

FOR ELASTOMERIC CONCRETE FOR PRESERVATION, SEE SPECIAL PROVISIONS.

CONTRACTOR SHALL FIELD VERIFY THE EXISTING JOINT OPENING PRIOR TO ORDERING JOINT SEAL MATERIAL. IF ACTUAL JOINT OPENING VARIES FROM OPENING INDICATED IN DETAIL BY MORE THAN 1/4", NOTIFY ENGINEER REVISION TO THE JOINT SEAL SIZE MIGHT BE NECESSARY.

DEMOLISH BRIDGE JOINT AREA TO THE NECESSARY DEPTH, SUCH THAT ELASTOMERIC CONCRETE SHALL BE FOUNDED ON SOUND CONCRETE OR REPAIR CONCRETE SUBSTRATE. IF SUCH EXCAVATION EXTENDS MORE THAN 2" BELOW THE BOTTOM OF THE PLANNED ELASTOMERIC CONCRETE HEADER, AS SHOWN, APPROVED CONCRETE REPAIR MATERIAL SHALL BE PLACED IN THE EXCAVATED AREA TO THE ELEVATION AT THE BOTTOM OF THE ELASTOMERIC CONCRETE.

FINAL SURFACE OF THE JOINT DEMOLITION AREA PRIOR TO PLACEMENT OF ELASTOMERIC CONCRETE AND/OR REPAIR CONCRETE SHALL BE REASONABLY FLAT AND LEVEL. ENGINEER SHALL DETERMINE THE ACCEPTABILITY OF THE SURFACE PRIOR TO PLACEMENT OF ELASTOMERIC CONCRETE OR CONCRETE REPAIR MATERIAL.

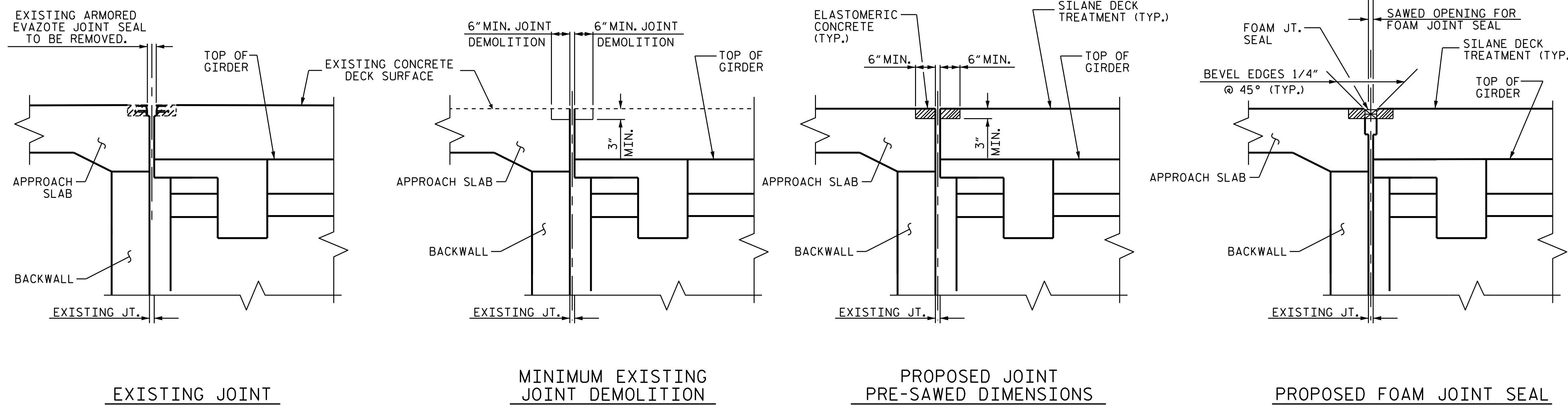

JOINT INSTALLATION SEQUENCE AT END BENTS SECTION A-A

JOINT REPAIR QUANTITY TABLE						
	BRIDGE JOINT DEMOLITION		ELASTOMERIC CONCRETE FOR PRESERVATION		FOAM JOINT SEALS FOR PRESERVATION	
	ESTIMATED	ACTUAL	ESTIMATED	ACTUAL	ESTIMATED	ACTUAL
END BENT 1	47.0 SF		11.8 CF		47.0 LF	
END BENT 2	47.0 SF		11.8 CF		47.0 LF	
* TOTAL	94.0 SF		23.6 CF		94.0 LF	

* BASED ON THE MINIMUM BLOCKOUT SHOWN.

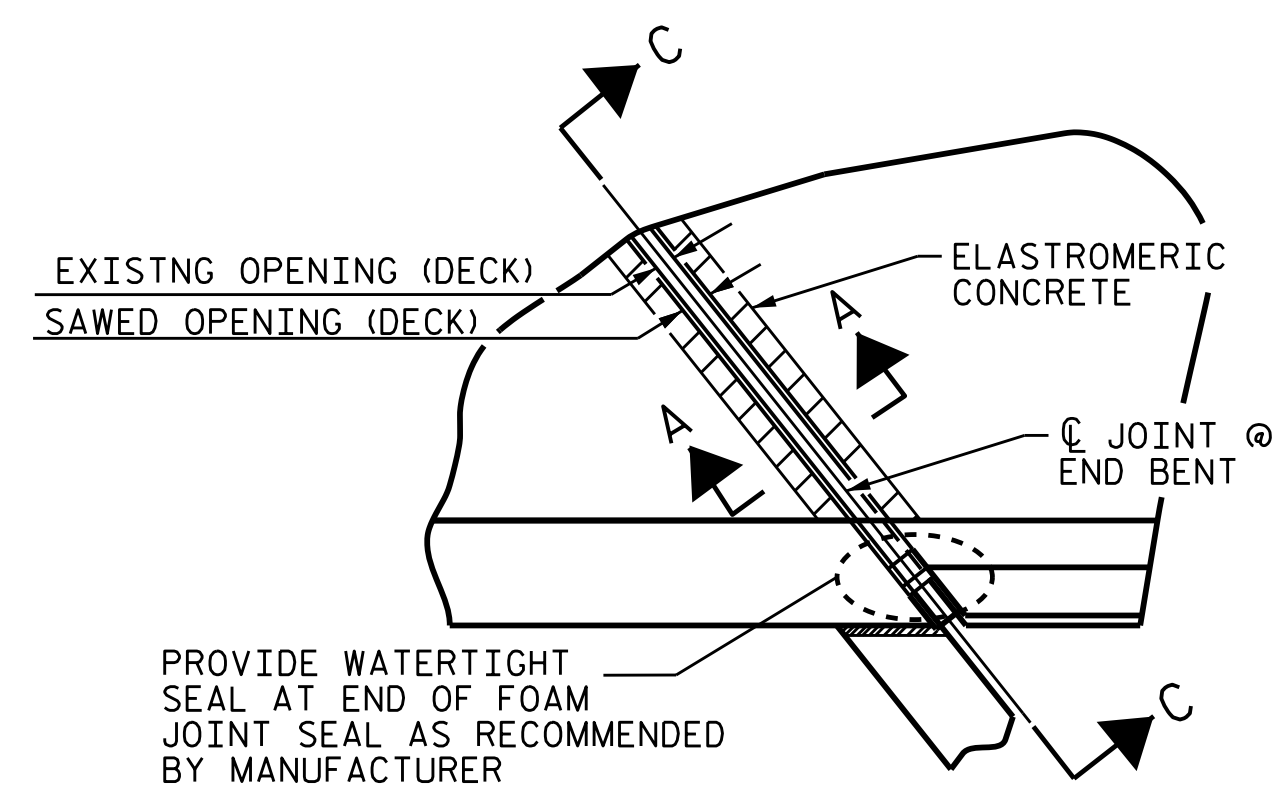

PLAN
(@ END BENT)

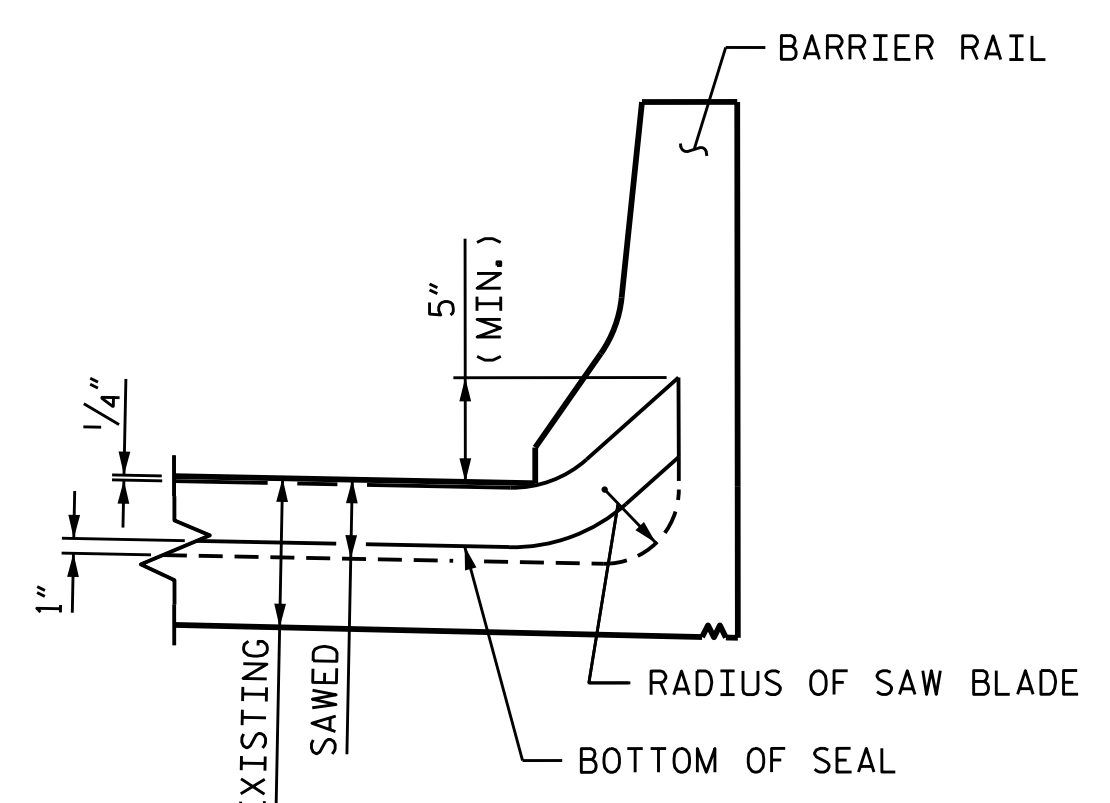

SECTION C-C

JOINT SEAL DETAILS AT END BENTS

PROJECT NO. I-5946B
RICHMOND COUNTY
 BRIDGE NO. 760183

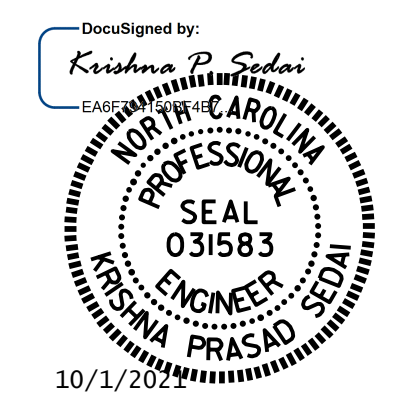

STATE OF NORTH CAROLINA
 DEPARTMENT OF TRANSPORTATION
 RALEIGH

**SUPERSTRUCTURE
 JOINT DETAILS**

DRAWN BY : C. RUIZ DATE : 01/2020
 CHECKED BY : A. SORSENGINH DATE : 06/2021

DOCUMENT NOT CONSIDERED
 FINAL UNLESS ALL
 SIGNATURES COMPLETED

REVISIONS						SHEET NO.
NO.	BY:	DATE:	NO.	BY:	DATE:	
1			3			S1-04
2			4			TOTAL SHEETS 6