

**This electronic collection of documents is provided  
for the convenience of the user  
and is Not a Certified Document –**

**The documents contained herein were originally issued  
and sealed by the individuals whose names and license  
numbers appear on each page, on the dates appearing  
with their signature on that page.**

**This file or an individual page  
shall not be considered a certified document.**

8/2/2021 8:42:21 AM U:\Projects\Signings\CADD\Pavement Markings\U-4405A - Revised\Plan Sheets\U-4405.pmp\_1-1B.dgn  
jhambricht

**T.I.P.: U-4405A**

**CONTRACT: C204404**

**STATE OF NORTH CAROLINA  
DEPARTMENT OF TRANSPORTATION**

**PAVEMENT MARKING PLAN  
CUMBERLAND COUNTY**

TIP NO. U - 4405A	SHEET NO. PMP - 1
APPROVED: <small>—SE87B34F8743F—</small>	
DATE: 8/2/2021	
SEAL 	
<b>DOCUMENT NOT CONSIDERED FINAL UNLESS ALL SIGNATURES COMPLETED</b>	



**INDEX**

SHEET NO.	DESCRIPTION
PMP-1	PAVEMENT MARKING PLAN TITLE AND NOTES SHEET
PMP-1A	REVISED ROADWAY STANDARD DRAWING #1205.04 (SHEET 2 of 2)
PMP-1B	PAVEMENT MARKING SCHEDULE
PMP-1C	CURB RAMP TYPE AND LOCATIONS
PMP-2-12	PAVEMENT MARKING DETAILS

**GENERAL NOTES**

- THE FOLLOWING GENERAL NOTES APPLY AT ALL TIMES FOR THE DURATION OF THE CONSTRUCTION PROJECT, EXCEPT WHEN OTHERWISE NOTED IN THE PLAN, OR DIRECTED BY THE ENGINEER.
- A) INSTALL PAVEMENT MARKINGS AND PAVEMENT MARKERS ON THE FINAL SURFACE AS FOLLOWS:
- | ROAD NAME | MARKING TYPE  | MARKER TYPE      |
|-----------|---------------|------------------|
| ALL ROADS | THERMOPLASTIC | PERMANENT RAISED |
- B) TIE PROPOSED PAVEMENT MARKING LINES TO EXISTING PAVEMENT MARKING LINES.
- C) REMOVE/REPLACE ANY CONFLICTING/DAMAGED PAVEMENT MARKINGS AND MARKERS.
- D) STOP BAR LOCATIONS AT NON-SIGNALIZED INTERSECTIONS MAY BE ADJUSTED AS DIRECTED BY THE ENGINEER.
- E) UNLESS OTHERWISE SPECIFIED, HEATED-IN-PLACE THERMOPLASTIC MAY BE USED IN LIEU OF EXTRUDED THERMOPLASTIC FOR STOP BARS, SYMBOLS, CHARACTERS AND DIAGONALS. IF HEATED-IN-PLACE IS USED, IT SHALL BE PAID FOR USING THE EXTRUDED THERMOPLASTIC PAY ITEM.
- F) UNLESS OTHERWISE SPECIFIED, HEATED-IN-PLACE THERMOPLASTIC MAY BE USED IN LIEU OF COLD APPLIED PLASTIC FOR STOP BARS, SYMBOLS, CHARACTERS AND DIAGONALS ON ASPHALT OR CONCRETE ROADWAYS. IF HEATED-IN-PLACE IS USED, IT SHALL BE PAID FOR USING THE COLD APPLIED PAY ITEM.
- G) SEE ROADWAY PLANS FOR ALTERNATE CURB RAMP DESIGNS WHEN INDICATED ON PAVEMENT MARKING DETAIL SHEETS.

**ROADWAY STANDARD DRAWING**

THE FOLLOWING ROADWAY STANDARDS AS APPEAR IN "ROADWAY STANDARD DRAWINGS" - PROJECT SERVICES UNIT - N.C. DEPARTMENT OF TRANSPORTATION - RALEIGH, N.C., DATED JANUARY 2018 ARE APPLICABLE TO THIS PROJECT AND BY REFERENCE HEREBY ARE CONSIDERED A PART OF THESE PLANS:

STD. NO.	TITLE
1205.01	PAVEMENT MARKINGS - LINE TYPES AND OFFSETS
1205.02	PAVEMENT MARKINGS - TWO-LANE AND MULTILANE ROADWAYS
1205.04	PAVEMENT MARKINGS - INTERSECTIONS
1205.05	PAVEMENT MARKINGS - TURN LANES
1205.06	PAVEMENT MARKINGS - LANE DROPS
1205.07	PAVEMENT MARKINGS - PEDESTRIAN CROSSWALKS
1205.08	PAVEMENT MARKINGS - SYMBOLS AND WORD MESSAGES
1205.09	PAVEMENT MARKINGS - PAINTED ISLANDS
1205.10	PAVEMENT MARKINGS - SCHOOL AREAS
1205.15	PAVEMENT MARKINGS - SUPERSTREETS
1250.01	RAISED PAVEMENT MARKERS - INSTALLATION SPACING
1251.01	RAISED PAVEMENT MARKERS - PERMANENT AND TEMPORARY
1261.01	GUARDRAIL AND BARRIER DELINEATORS - INSTALLATION SPACING
1261.02	GUARDRAIL AND BARRIER DELINEATORS - TYPES AND MOUNTING
1262.01	GUARDRAIL END DELINEATION

**PLAN REVIEWED BY: N.C.D.O.T. SIGNING AND DELINEATION UNIT**

<b>AYMAN ALQUDWAH, P.E.</b>	SIGNING & DELINEATION REGIONAL ENGINEER
<b>STACEY JOHNS</b>	SIGNING & DELINEATION PROJECT DESIGN ENGINEER

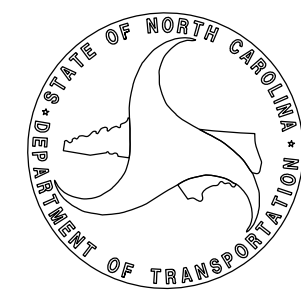

**PLAN PREPARED BY: Stantec Consulting Services, Inc.**

<b>BETSY L. WATSON, P.E.</b>	Senior Principal
<b>JAY WOOLARD, P.E.</b>	Senior Transportation Engineer
<b>JAMES HAMBRIGHT</b>	Senior Transportation Technician



Stantec Consulting Services Inc.  
801 Jones Franklin Road  
Suite 300  
Raleigh, NC 27606  
Tel. (919) 851-6866  
Fax. (919) 851-7024  
www.stantec.com  
License No. F-0672



TIP NO.	SHEET NO.
U-4405	AMP - 1A
APPROVED: <i>Matthew V. Springer</i>	
DATE: 8/13/2019	
SEAL	

STATE OF NORTH CAROLINA  
 DEPT. OF TRANSPORTATION  
 DIVISION OF HIGHWAYS  
 RALEIGH, N.C.

ENGLISH DETAIL DRAWING FOR  
**PAVEMENT MARKINGS**  
 INTERSECTIONS

SHEET 2 OF 2  
**1205D04**

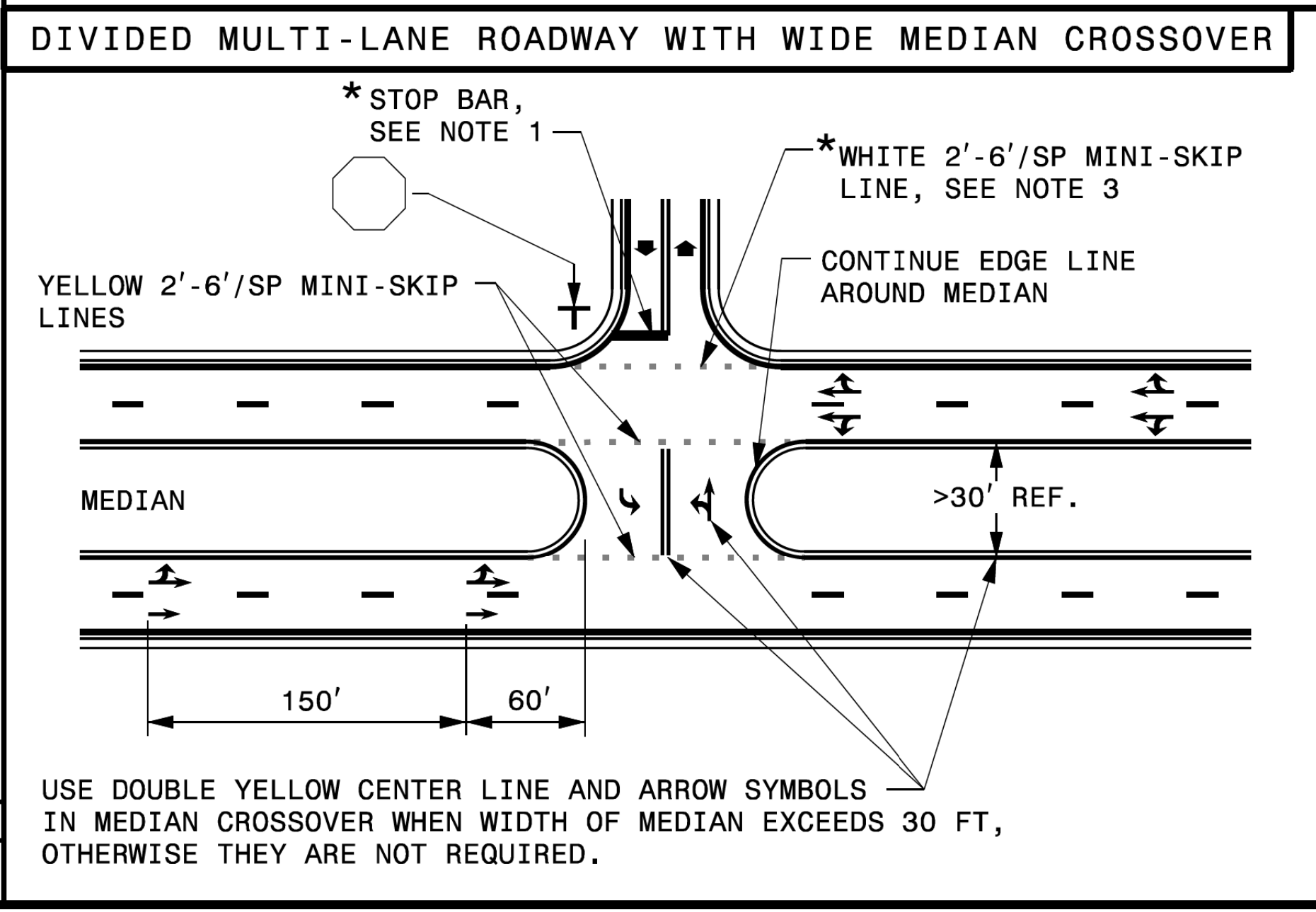
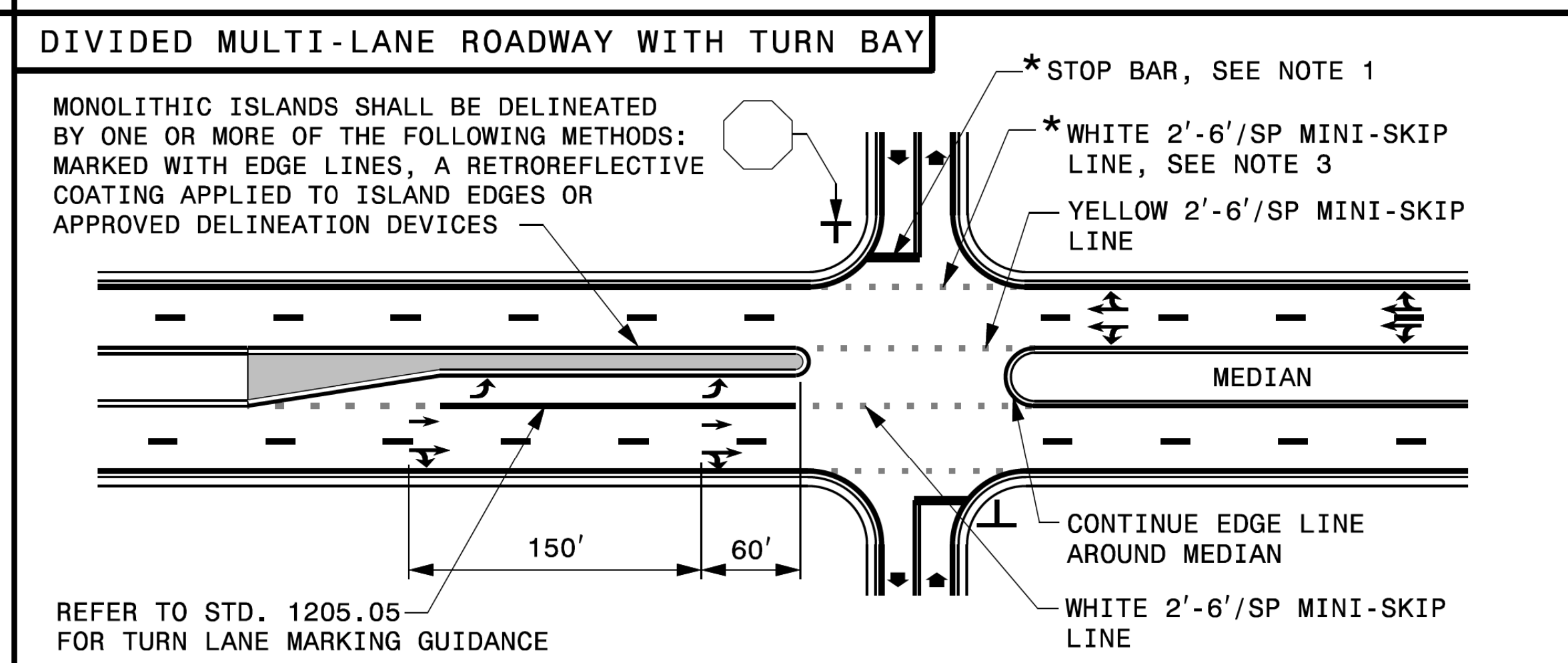
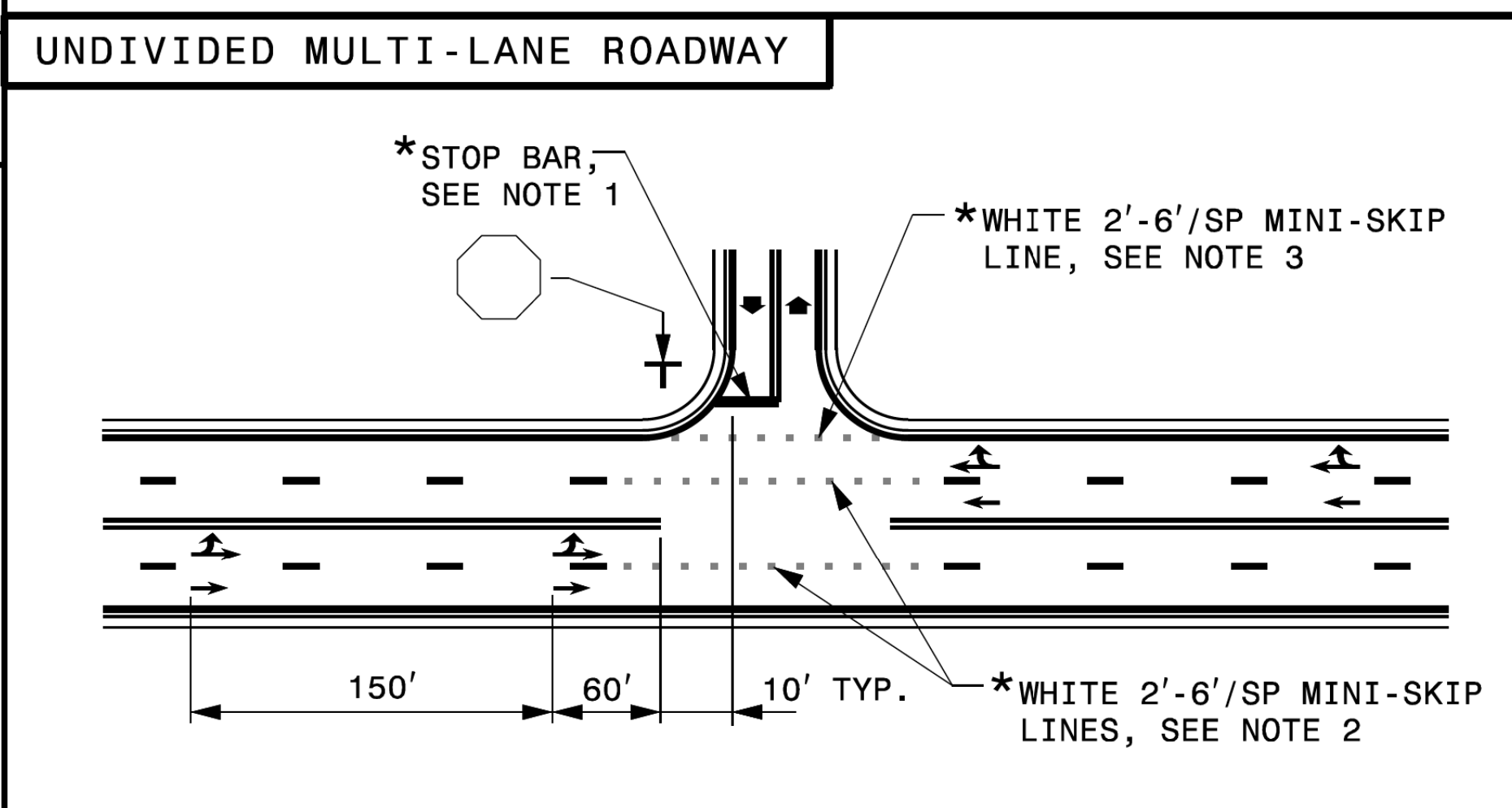
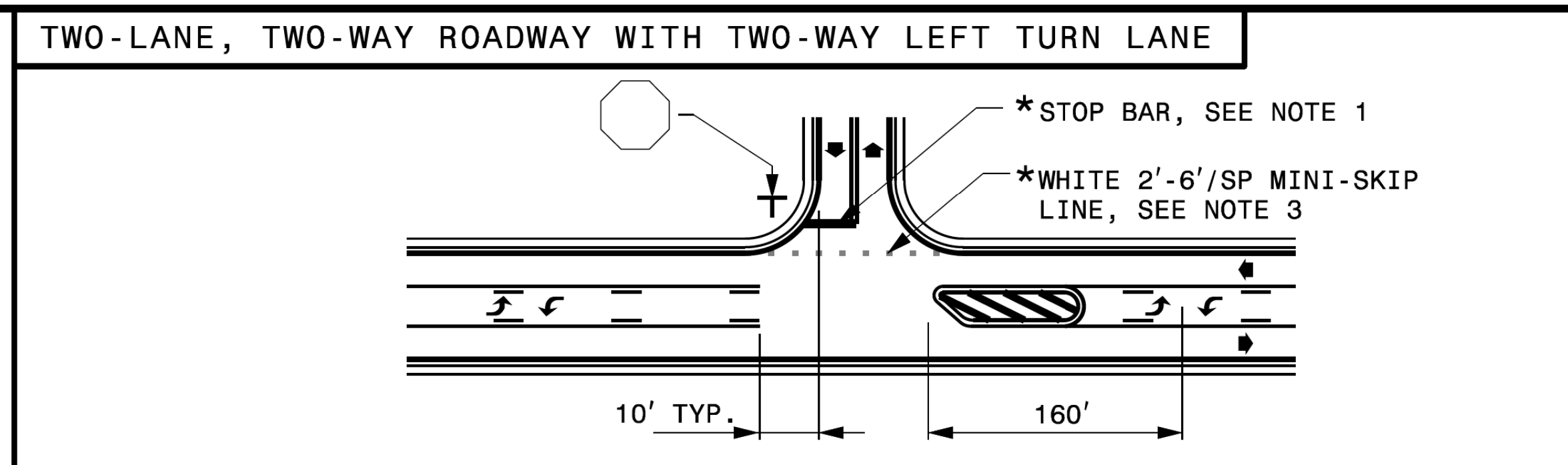
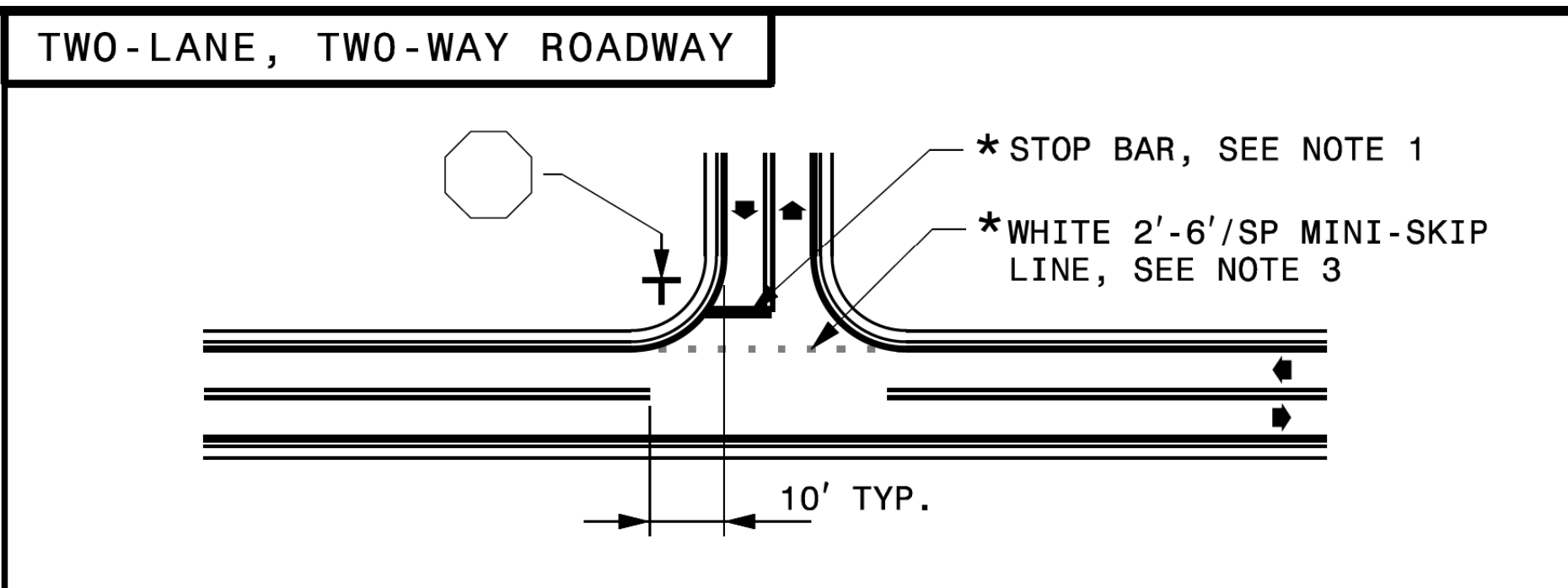

**GENERAL NOTES:**

- 1- PLACEMENT OF STOP BARS AT NON-SIGNALIZED INTERSECTIONS IS OPTIONAL AND USED WHERE IT IS IMPORTANT TO INDICATE THE POINT WHICH VEHICLES ARE REQUIRED TO STOP. PLACE STOP BARS NO LESS THAN 4 FEET AND NO MORE THAN 30 FEET FROM THE NEAREST EDGE OF THE INTERSECTING ROADWAY. USE 10 FEET AS THE TYPICAL SETBACK DISTANCE OR AS DIRECTED BY THE ENGINEER.
- 2- MINI-SKIP LANE LINE EXTENSIONS SHOULD BE USED AT INTERSECTIONS THAT HAVE REDUCED VISIBILITY CONDITIONS SUCH AS OFFSET, SKEWED, OR CURVED ROADWAYS.
- 3- MINI-SKIP EDGE LINE EXTENSIONS MAY BE PLACED THROUGH INTERSECTIONS AND MAJOR DRIVEWAYS.
- 4- REFER TO ROADWAY STANDARD DRAWINGS 1205.01, 1205.02, 1205.05, 1205.08 AND 1205.09 FOR ADDITIONAL PAVEMENT MARKING GUIDANCE.

**LEGEND**

STOP SIGN	STATIONARY SIGN
DIRECTION OF TRAFFIC FLOW	PAVEMENT MARKING SYMBOLS
* OPTIONAL	



SHEET 2 OF 2  
**1205D04**

STATE OF NORTH CAROLINA  
 DEPT. OF TRANSPORTATION  
 DIVISION OF HIGHWAYS  
 RALEIGH, N.C.

ENGLISH DETAIL DRAWING FOR  
**PAVEMENT MARKINGS**  
 INTERSECTIONS

SHEET 2 OF 2  
**1205D04**

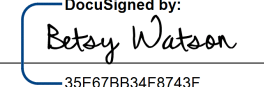
**REVISED PAVEMENT MARKING ROADWAY STANDARD DRAWING**

TIP NO. U - 4405A	SHEET NO. PMP - 1B
APPROVED:  DATE: 8/2/2021	
SEAL	
	
DOCUMENT NOT CONSIDERED FINAL UNLESS ALL SIGNATURES COMPLETED	





## PAVEMENT MARKING SCHEDULE

<u>THERMOPLASTIC (4", 90 MILS)</u>		
T1	WHITE EDGELINE (4", 90 MIL)	4685000000-E
T2	WHITE SOLID LANE LINE (4", 90 MIL)	4685000000-E
T3	10 FT. WHITE SKIP (4", 90 MIL)	4685000000-E
T4	3 FT. - 9 FT./SP WHITE MINISKIP (4", 90 MIL)	4685000000-E
T5	2 FT. - 6 FT./SP WHITE MINISKIP (4", 90 MIL)	4685000000-E
T10	YELLOW EDGELINE (4", 90 MIL)	4685000000-E
T11	YELLOW SINGLE CENTER (4", 90 MIL)	4685000000-E
T13	YELLOW DOUBLE CENTER (4", 90 MIL)	4685000000-E
T14	2 FT. - 6 FT./SP YELLOW MINISKIP (4", 90 MIL)	4685000000-E
<u>THERMOPLASTIC (8", 90 MILS)</u>		
T40	WHITE GORELINE (8", 90 MIL)	4695000000-E
T41	WHITE DIAGONAL (8", 90 MIL)	4695000000-E
T42	YELLOW DIAGONAL (8", 90 MIL)	4695000000-E
T43	WHITE SOLID LANE LINE (8", 90 MIL)	4695000000-E
T44	3 FT. - 9 FT./SP WHITE MINISKIP (8", 90 MIL)	4695000000-E
T46	WHITE CROSSWALK LINE (8", 90 MIL)	4695000000-E
<u>THERMOPLASTIC (24", 90 MILS)</u>		
T61	WHITE STOPBAR (24", 90 MIL)	4891000000-E
T62	WHITE CROSSWALK LINE (24", 90 MIL)	4891000000-E
<u>THERMOPLASTIC PAVEMENT MARKING SYMBOLS (90 MILS)</u>		
T70	LEFT TURN ARROW (90 MIL)	4725000000-E
T71	RIGHT TURN ARROW (90 MIL)	4725000000-E
T72	STRAIGHT ARROW (90 MIL)	4725000000-E
T73	COMBO. LEFT/STRAIGHT ARROW (90 MIL)	4725000000-E
T74	COMBO. RIGHT/STRAIGHT ARROW (90 MIL)	4725000000-E
T78	COMBO. LEFT/U-TURN ARROW (90 MIL)	4725000000-E
<u>THERMOPLASTIC PAVEMENT MARKING CHARACTER (90 MILS)</u>		
T100	ALPHANUMERIC CHAR. (90 MIL)	4720000000-E

8/2/2021 1:11:11 PM Us:\Traffic\Signing\CADD\Pavement\Markings\U-4405A - Revised\Plan Sheets\U-4405\_pmp-1B.dgn jhambright

PAVEMENT MARKING DETAIL

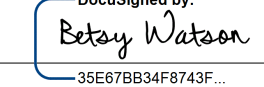

TIP NO.	SHEET NO.
U - 4405A	PMP - 1C
APPROVED: 	
DATE: 8/2/2021	
SEAL	
	
DOCUMENT NOT CONSIDERED FINAL UNLESS ALL SIGNATURES COMPLETED	





CURB RAMP NUMBER	CURB RAMP LOCATION		CURB RAMP TYPE
	STATION	OFFSET	
1	-Y50- Sta. 15+18 +/-	32.87' RT	STANDARD
2	-Y50- Sta. 15+45 +/-	44.09' LT	STANDARD
3	-L1- Sta. 96+34 +/-	64.10' LT	STANDARD
4	-L1- Sta. 96+35 +/-	49.45' RT	TYPE 2
5	-Y51- Sta. 11+62 +/-	16.17' RT	STANDARD
6	-Y51- Sta. 11+61 +/-	16.58' LT	STANDARD
7	-Y52- Sta. 11+43 +/-	25.99' RT	STANDARD
8	-Y52- Sta. 11+46 +/-	20.85' LT	STANDARD
9	-Y53- Sta. 12+33 +/-	25.86' RT	STANDARD
10	-Y53- Sta. 12+33 +/-	26.19' LT	STANDARD
11	-Y1- Sta. 14+62 +/-	44.66' RT	STANDARD
12	-Y1- Sta. 14+63 +/-	43.35' LT	STANDARD
13	-Y2- Sta. 10+88 +/-	21.67' RT	STANDARD
14	-Y2- Sta. 10+88 +/-	23.60' LT	STANDARD
15	-L- Sta. 25+37 +/-	62.77' LT	STANDARD
16	-L- Sta. 25+73 +/-	62.45' LT	STANDARD
17	-L- Sta. 28+86 +/-	94.95' LT	STANDARD
18	-L- Sta. 29+23 +/-	94.95' LT	STANDARD
19	-L- Sta. 31+65 +/-	70.06' LT	STANDARD
20	-L- Sta. 32+31 +/-	68.66' LT	TYPE 4A
21	-L- Sta. 32+36 +/-	64.33' LT	
22	-L- Sta. 32+36 +/-	12.90' LT	STANDARD
23	-L- Sta. 32+36 +/-	12.90' RT	STANDARD
24	-L- Sta. 32+36 +/-	40.50' RT	TYPE 3
25	-L- Sta. 35+97 +/-	62.66' LT	STANDARD
26	-L- Sta. 36+41 +/-	62.47' LT	STANDARD
27	-L- Sta. 39+41 +/-	59.88' LT	STANDARD
28	-L- Sta. 39+89 +/-	59.43' LT	STANDARD
29	-L- Sta. 41+63 +/-	59.43' LT	STANDARD
30	-L- Sta. 42+08 +/-	59.43' LT	STANDARD
31	-L- Sta. 44+72 +/-	57.28' RT	STANDARD
32	-L- Sta. 44+73 +/-	2.75' RT	MEDIAN CUT
33	-L- Sta. 44+73 +/-	13.75' LT	MEDIAN CUT
34	-L- Sta. 44+73 +/-	40.58' LT	STANDARD
35	-Y4- Sta. 17+89 +/-	37.23' RT	STANDARD
36	-Y4- Sta. 17+82 +/-	44.24' LT	STANDARD
37	-L- Sta. 45+95 +/-	54.57' LT	STANDARD
38	-L- Sta. 45+94 +/-	2.75' LT	MEDIAN CUT
39	-L- Sta. 45+94 +/-	13.75' RT	MEDIAN CUT
40	-L- Sta. 45+95 +/-	55.29' RT	STANDARD
41	-Y4- Sta. 19+11 +/-	48.66' LT	STANDARD
42	-Y4- Sta. 19+18 +/-	45.06' RT	STANDARD
43	-L- Sta. 48+12 +/-	59.73' RT	STANDARD
44	-L- Sta. 48+77 +/-	60.00' RT	STANDARD
45	-L- Sta. 49+53 +/-	59.54' LT	STANDARD
46	-L- Sta. 49+92 +/-	59.69' LT	STANDARD
47	-L- Sta. 50+67 +/-	60.02' RT	STANDARD
48	-L- Sta. 51+38 +/-	60.09' RT	STANDARD
49	-L- Sta. 56+61 +/-	59.26' LT	STANDARD
50	-L- Sta. 57+07 +/-	59.61' LT	STANDARD
51	-L- Sta. 56+97 +/-	59.73' RT	STANDARD
52	-L- Sta. 57+74 +/-	59.71' RT	STANDARD
53	-L- Sta. 64+86 +/-	59.30' RT	STANDARD
54	-L- Sta. 65+15 +/-	59.20' RT	STANDARD
55	-L- Sta. 66+17 +/-	59.17' RT	STANDARD
56	-L- Sta. 66+62 +/-	59.03' RT	STANDARD
57	-L- Sta. 66+66 +/-	85.47' LT	TYPE 2
58	-L- Sta. 67+08 +/-	84.01' LT	TYPE 2
59	-L- Sta. 66+94 +/-	60.42' RT	STANDARD

CURB RAMP NUMBER	CURB RAMP LOCATION		CURB RAMP TYPE
	STATION	OFFSET	
60	-L- Sta. 67+26 +/-	56.49' RT	TYPE 1
61	-L- Sta. 68+40 +/-	56.50' RT	TYPE 1
62	-L- Sta. 69+08 +/-	56.50' RT	TYPE 1
63	-L- Sta. 72+06 +/-	67.50' RT	TYPE 1
64	-L- Sta. 72+68 +/-	67.50' RT	TYPE 1
65	-L- Sta. 75+63 +/-	62.67' RT	STANDARD
66	-L- Sta. 75+64 +/-	2.75' RT	MEDIAN CUT
67	-L- Sta. 75+64 +/-	13.75' LT	MEDIAN CUT
68	-L- Sta. 75+64 +/-	49.76' LT	STANDARD
69	-Y5- Sta. 20+39 +/-	45.06' RT	STANDARD
70	-Y5- Sta. 20+39 +/-	53.42' LT	STANDARD
71	-L- Sta. 77+11 +/-	65.15' LT	STANDARD
72	-L- Sta. 77+10 +/-	53.59' RT	STANDARD
73	-Y5- Sta. 21+82 +/-	44.52' LT	STANDARD
74	-Y5- Sta. 21+87 +/-	64.05' RT	STANDARD
75	-L- Sta. 85+34 +/-	67.11' LT	STANDARD
76	-L- Sta. 86+27 +/-	68.42' LT	STANDARD
77	-Y6- Sta. 10+53 +/-	28.89' RT	STANDARD
78	-Y6- Sta. 10+56 +/-	33.20' LT	STANDARD
79	-L- Sta. 98+31 +/-	64.84' RT	STANDARD
80	-L- Sta. 98+31 +/-	75.47' LT	STANDARD
81	-Y7- Sta. 13+94 +/-	85.64' RT	STANDARD
82	-Y7- Sta. 13+98 +/-	53.67' LT	STANDARD
83	-L- Sta. 100+04 +/-	71.07' LT	STANDARD
84	-L- Sta. 100+05 +/-	76.96' RT	STANDARD
85	-Y7- Sta. 15+72 +/-	67.73' LT	STANDARD
86	-Y7- Sta. 15+72 +/-	68.10' RT	STANDARD
87	-L- Sta. 101+96 +/-	86.47' LT	STANDARD
88	-L- Sta. 102+40 +/-	87.63' LT	STANDARD
89	-L- Sta. 101+91 +/-	65.45' RT	STANDARD
90	-L- Sta. 102+39 +/-	65.16' RT	STANDARD

8/2/2021  
 Us\Traffic\Signing\CADD\Pavement\Markings\U-4405A - Revised\Plan Sheets\U-4405\_pmp-1c.dgn  
 jhambright

PAVEMENT MARKING DETAIL  
CURB RAMP LOCATION INFORMATION

TIP NO. U - 4405A	SHEET NO. PMP - 2
APPROVED: <i>Betsy Watson</i> DATE: 8/2/2021	
SEAL 	
DOCUMENT NOT CONSIDERED FINAL UNLESS ALL SIGNATURES COMPLETED	
	

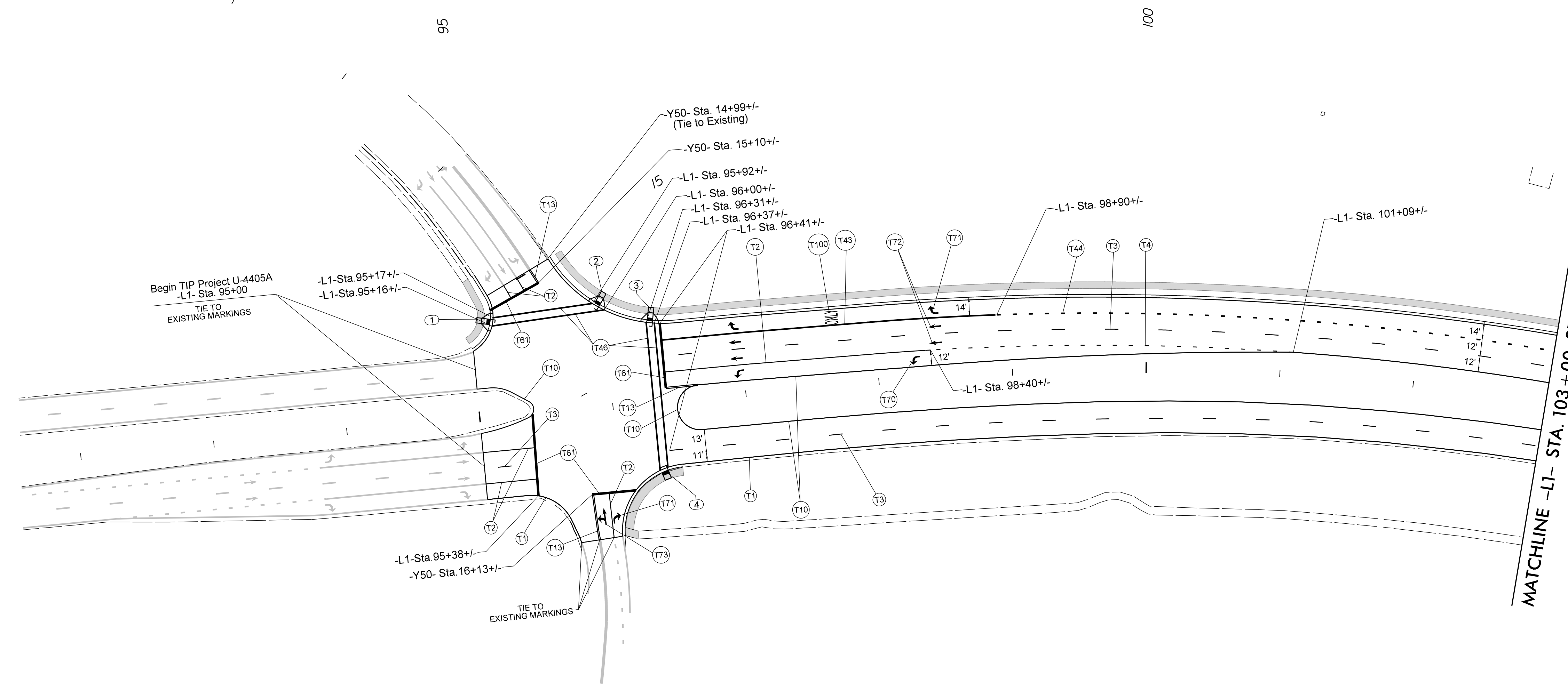

8/2/2021  
Us:\Traffic\Signing\CADD\Pavement\ Markings\U-4405A - Revised\Plan Sheets\U-4405\_pmp-2.dgn  
jhambricht

PAVEMENT MARKING DETAIL



TIP NO. U-4405A	SHEET NO. PMP-3
APPROVED: <i>Betsy Watson</i> <small>35E67BB34F8743F</small>	
DATE: 8/2/2021	
SEAL 	
DOCUMENT NOT CONSIDERED FINAL UNLESS ALL SIGNATURES COMPLETED	

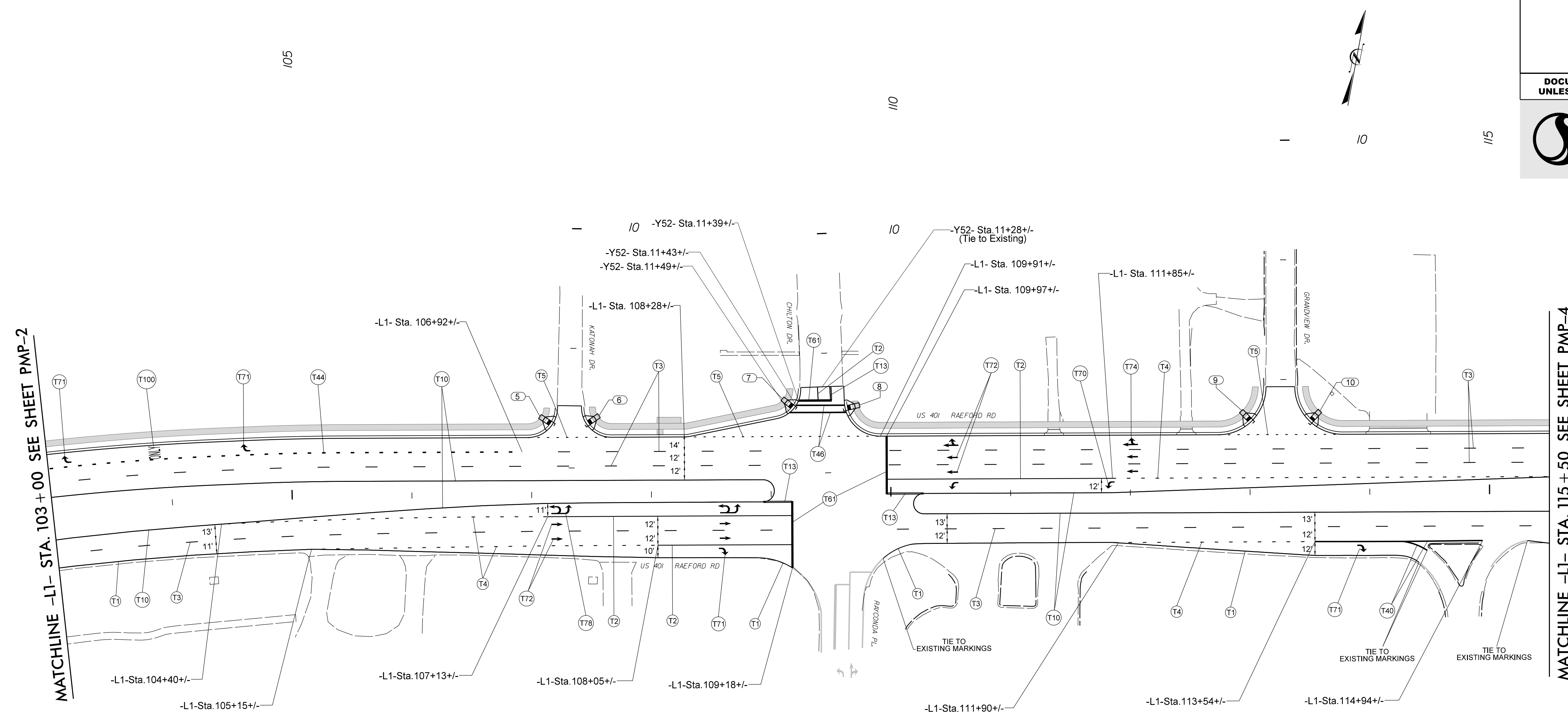

MATCHLINE -L1- STA. 103+00 SEE SHEET PMP-2

MATCHLINE -L1- STA. 115+50 SEE SHEET PMP-4

PAVEMENT MARKING DETAIL

8/2/2021  
Us:\Traffic\Signing\CADD\Pavement\ Markings\U-4405A - Revised\Plan Sheets\U-4405\_pmp\_3.dgn  
jhambricht

TIP NO. U-4405A	SHEET NO. PMP-4
APPROVED: <i>Betsy Watson</i> <small>35E878B84F8743F...</small>	
DATE: 8/2/2021	
SEAL 	
DOCUMENT NOT CONSIDERED FINAL UNLESS ALL SIGNATURES COMPLETED	



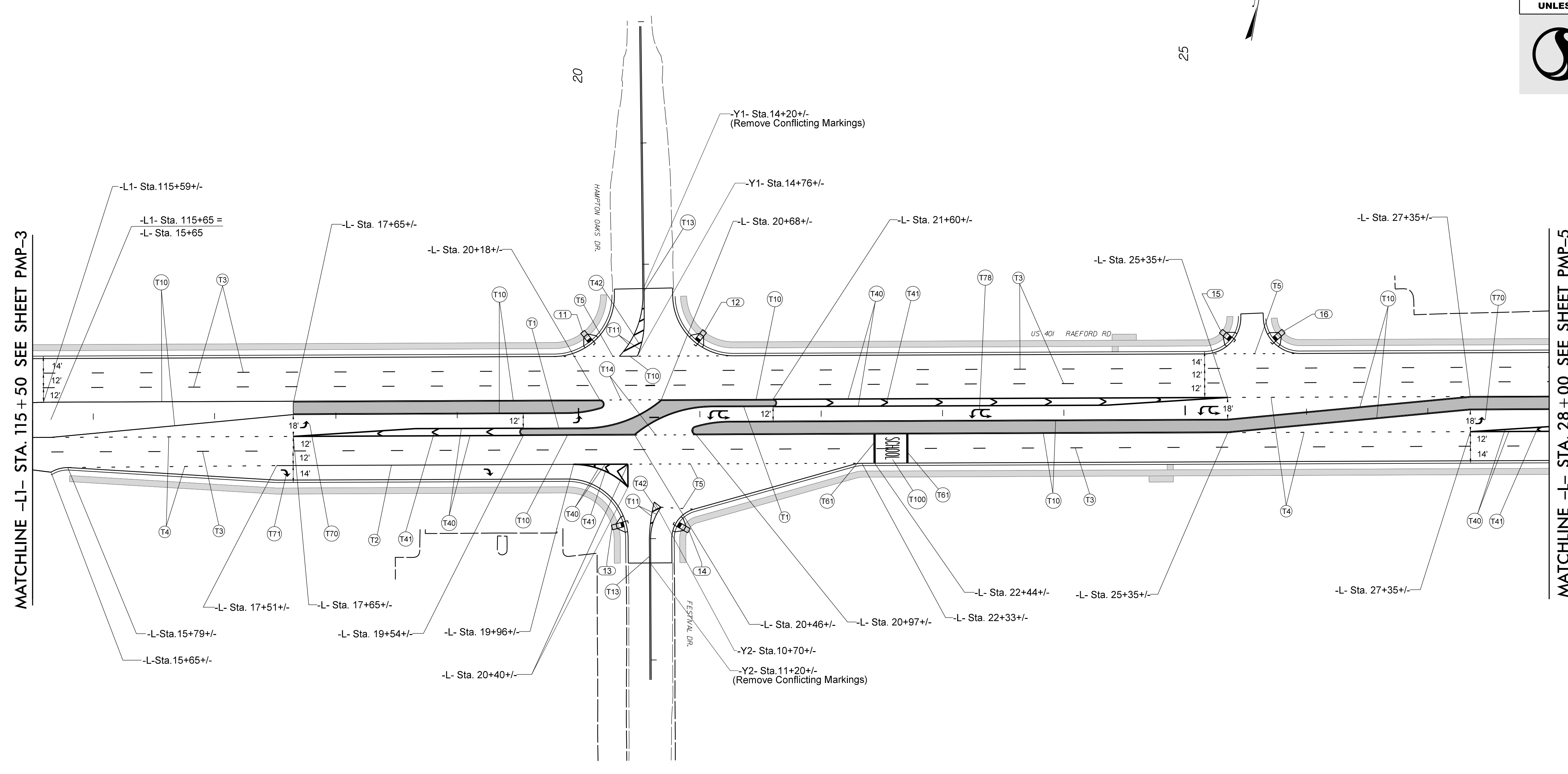
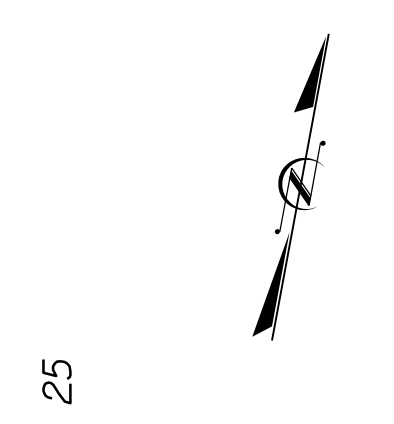

1/5



8/2/2021  
Us:\Traffic\Signing\CADD\Pavement\Markings\U-4405A - Revised\Plan Sheets\U-4405\_pmp\_4.dgn  
jhambricht

PAVEMENT MARKING DETAIL

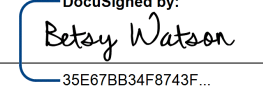

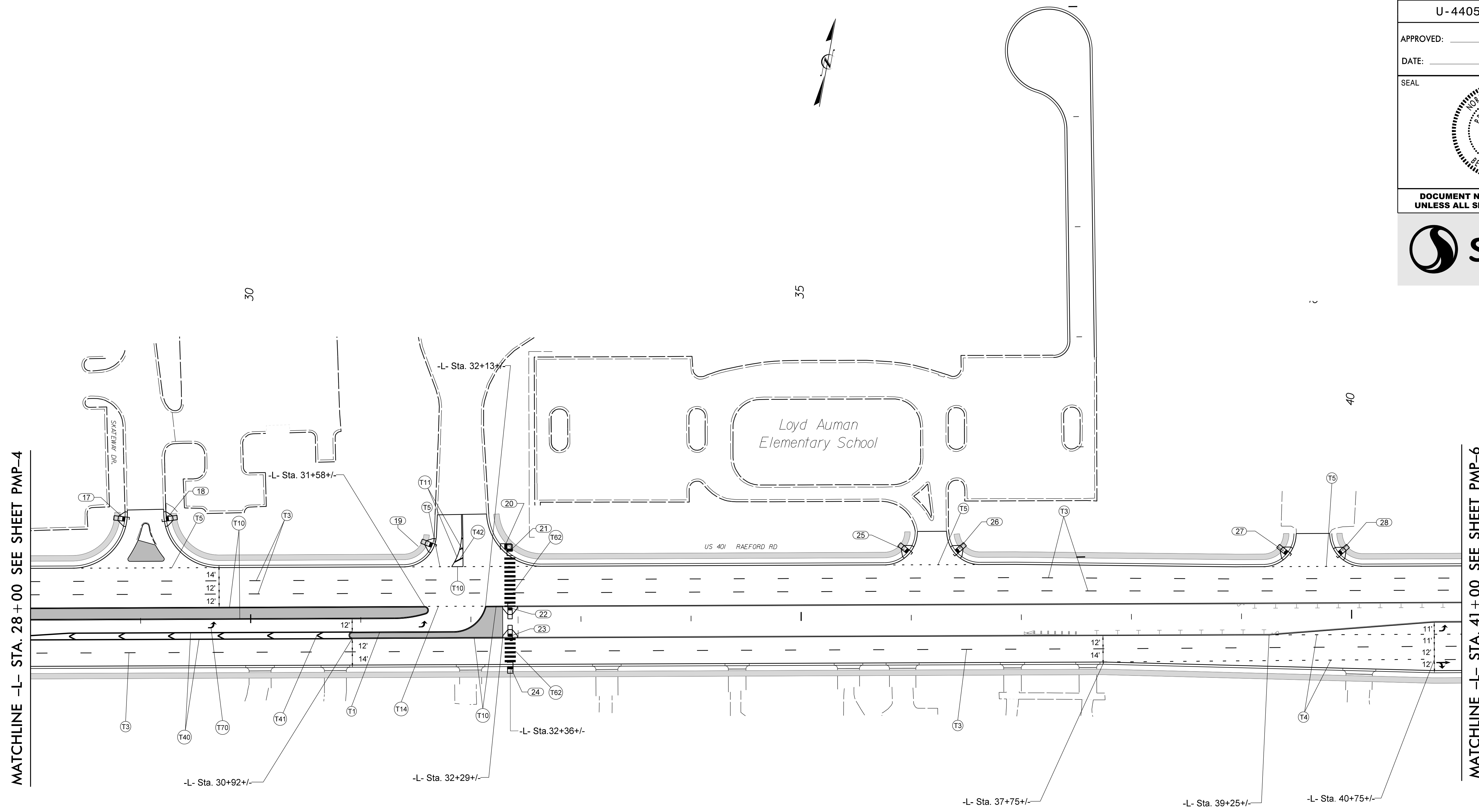

TIP NO. U-4405A	SHEET NO. PMP-5
APPROVED:  DATE: 8/2/2021	
SEAL 	
DOCUMENT NOT CONSIDERED FINAL UNLESS ALL SIGNATURES COMPLETED	
	

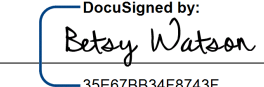

8/2/2021  
UsTraffic\Signing\CADD\Pavement\Markings\U-4405A - Revised\Plan Sheets\U-4405\_pmp\_5.dgn  
jhambright

PAVEMENT MARKING DETAIL

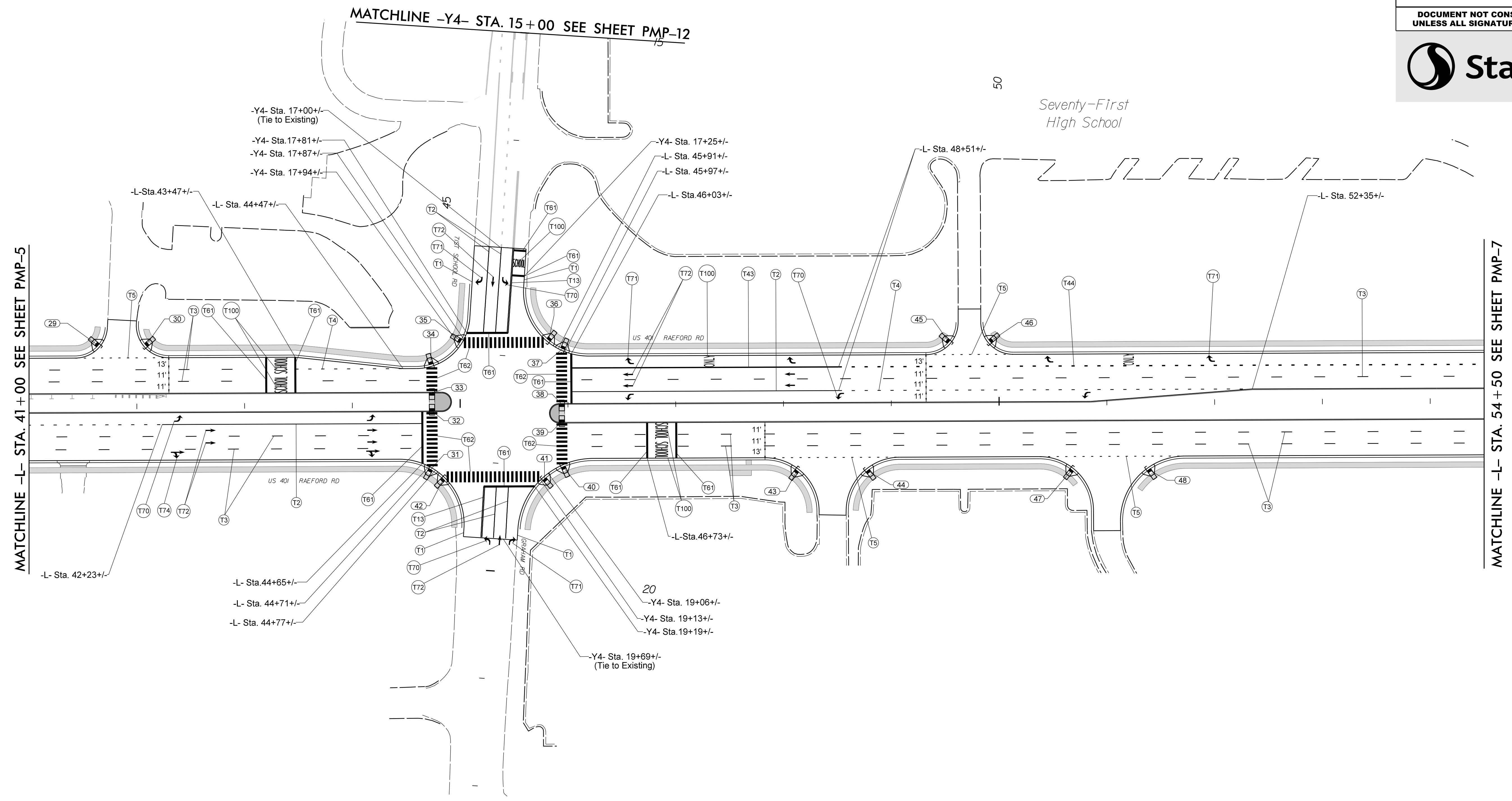

TIP NO. U - 4405A	SHEET NO. PMP - 6
APPROVED:  35E78B34F8743F	
DATE: 8/2/2021	
SEAL 	
DOCUMENT NOT CONSIDERED FINAL UNLESS ALL SIGNATURES COMPLETED	



8/2/2021  
UsTraffic\Signing\CADD\Pavement\Markings\U-4405A - Revised\Plan Sheets\U-4405-pmp-6.dgn  
jhambricht

PAVEMENT MARKING DETAIL

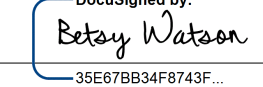

TIP NO. U-4405A	SHEET NO. PMP-7
APPROVED:  35E67B834F8743F	
DATE: 8/2/2021	
SEAL 	
DOCUMENT NOT CONSIDERED FINAL UNLESS ALL SIGNATURES COMPLETED	

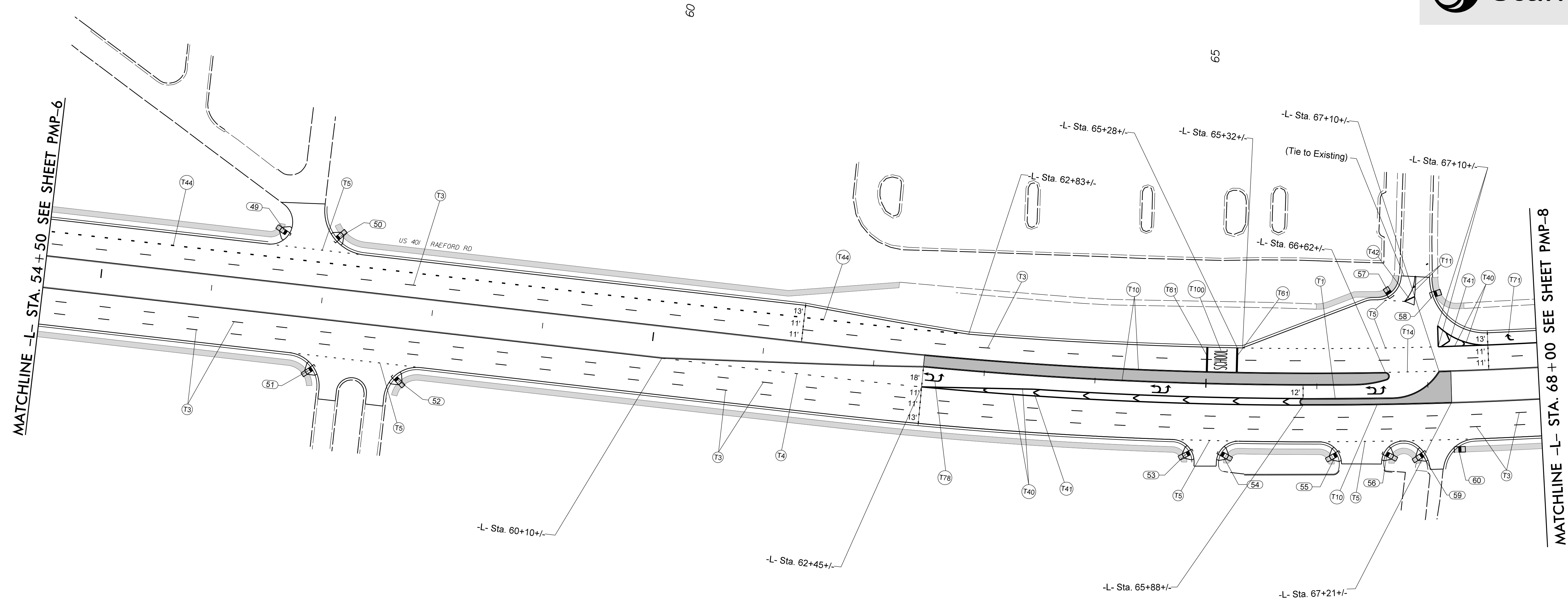

8/2/2021  
UsTraffic\Signing\CADD\Pavement\Markings\U-4405A - Revised\Plan Sheets\U-4405A.pmp-7.dgn  
jhambright

PAVEMENT MARKING DETAIL





TIP NO. U-4405A	SHEET NO. PMP-9
APPROVED: <i>Betsy Watson</i> 8/2/2021	
SEAL 	
DOCUMENT NOT CONSIDERED FINAL UNLESS ALL SIGNATURES COMPLETED	

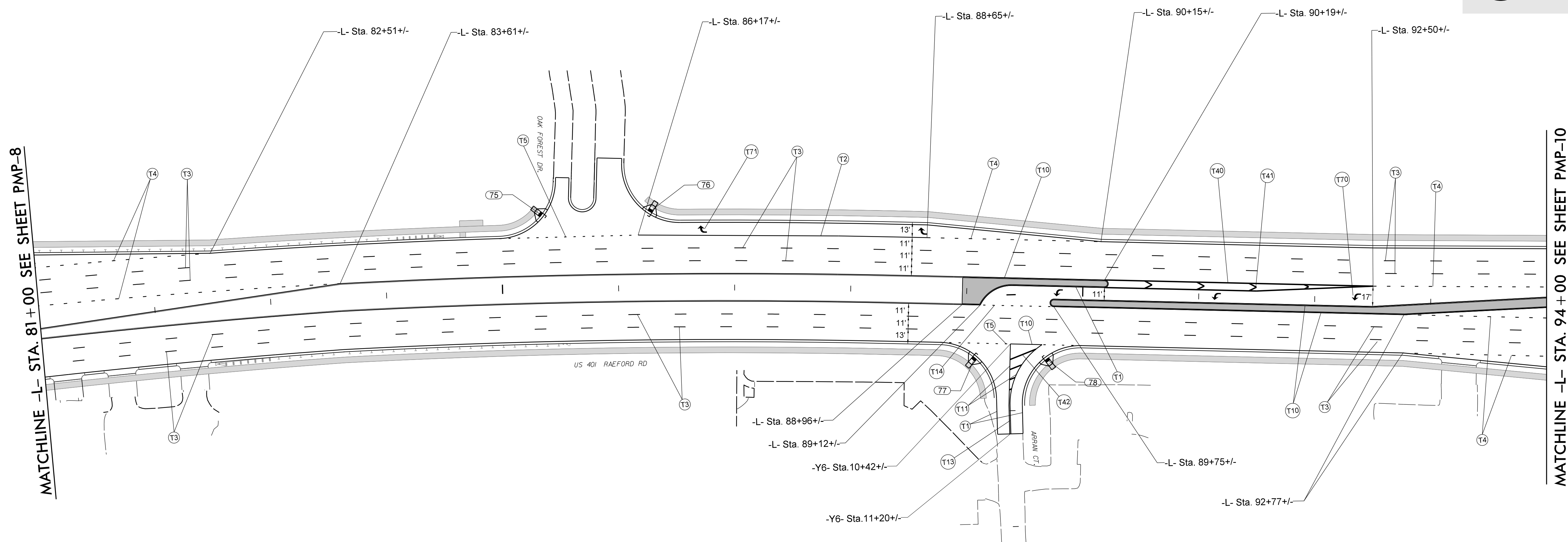



8/2/2021  
 Us:\Traffic\Signing\CADD\Pavement\Markings\U-4405A - Revised\Plan Sheets\U-4405A\_pmp\_9.dgn  
 jhambright

PAVEMENT MARKING DETAIL



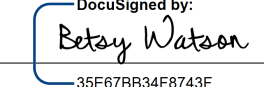

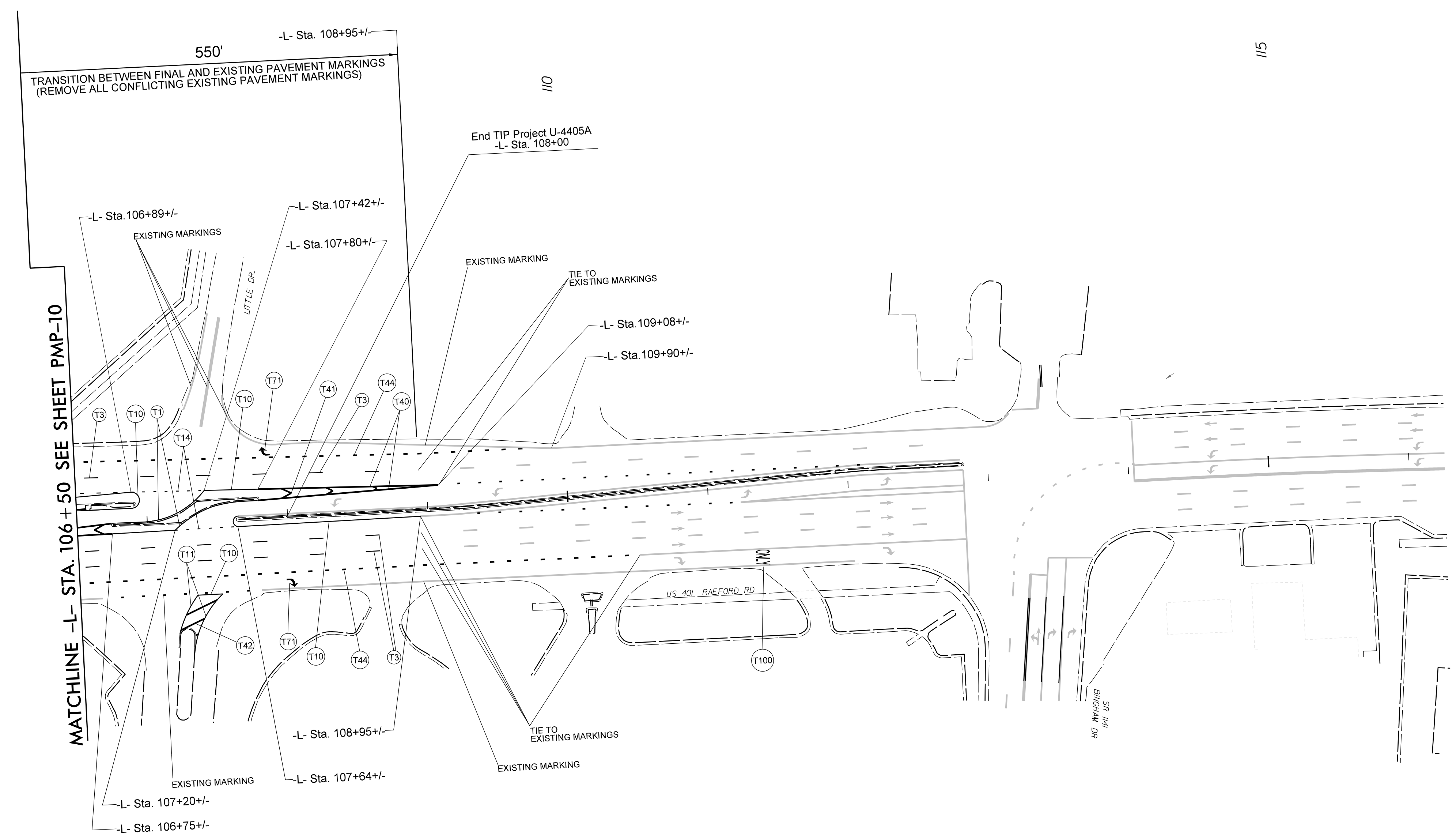

TIP NO. U-4405A	SHEET NO. PMP-11
APPROVED:  33E67B834F8743F	
DATE: 8/2/2021	
SEAL 	
DOCUMENT NOT CONSIDERED FINAL UNLESS ALL SIGNATURES COMPLETED	
	

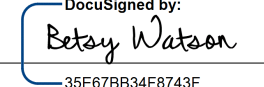

8/2/2021  
UsTraffic\Signing\CADD\Pavement\Markings\U-4405A - Revised\Plan Sheets\U-4405\_pmp\_11.dgn  
jhambricht

PAVEMENT MARKING DETAIL

TIP NO.	SHEET NO.
U - 4405A	PMP - 12
APPROVED: 	
DATE: 8/2/2021	
SEAL	
	
DOCUMENT NOT CONSIDERED FINAL UNLESS ALL SIGNATURES COMPLETED	

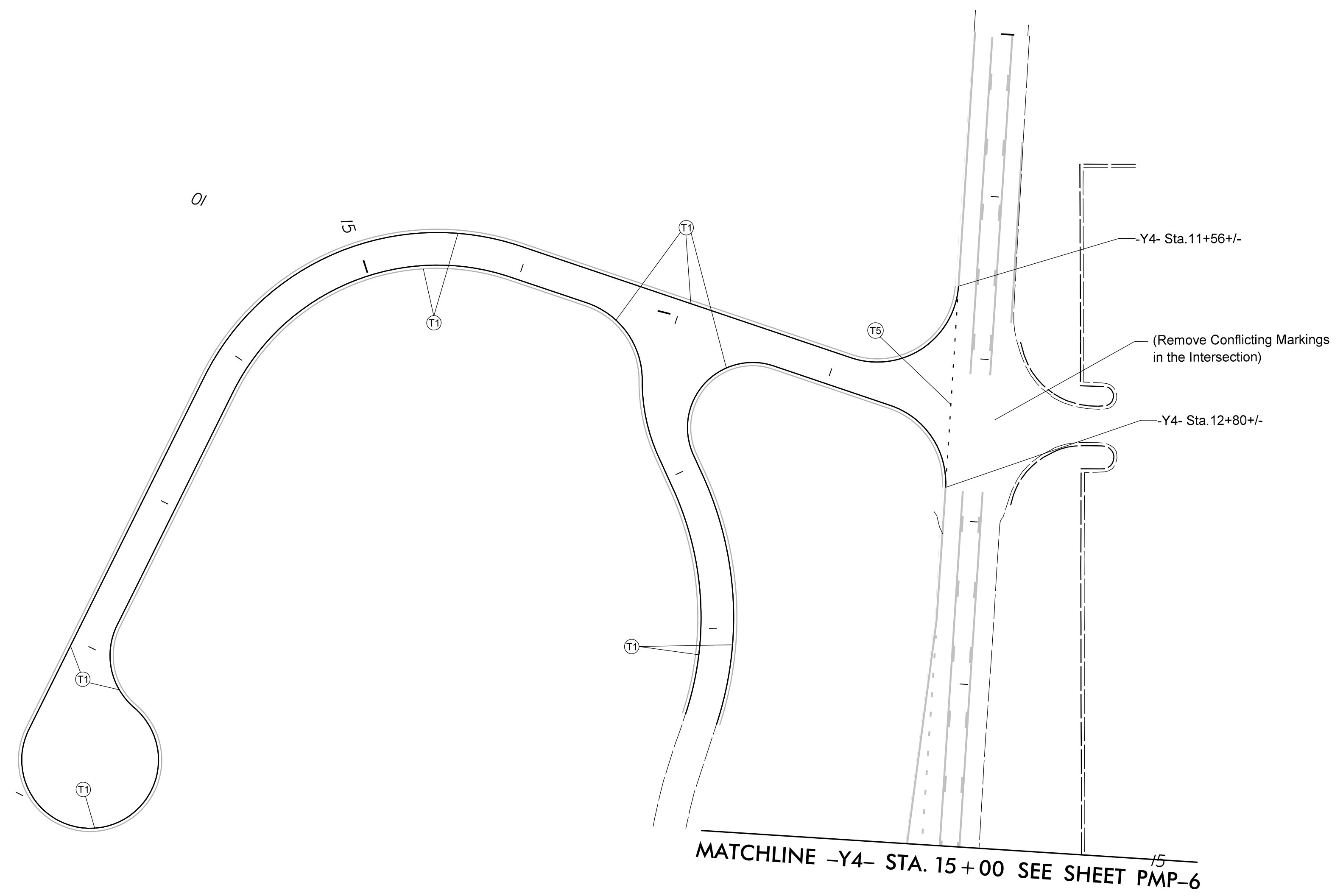

8/2/2021  
 Us\Traffic\Signing\CADD\Pavement\Markings\U-4405A - Revised\Plan Sheets\U-4405\_pmp\_12.dgn  
 jhambright

PAVEMENT MARKING DETAIL