

PROJECT REFERENCE NO.	U-4405	SHEET NO.	UC-03D
DESIGNED BY:	AMH	DRAWN BY:	AMH/AB
CHECKED BY:	AMH	APPROVED BY:	BRO
REVISED:			
NORTH CAROLINA DEPARTMENT OF TRANSPORTATION			
UTILITIES ENGINEERING SEC. PHONE: (919) 707-6690 FAX: (919) 250-4151		UTILITY CONSTRUCTION PLANS ONLY	

**UTILITY CONSTRUCTION**  
**DOCUMENT NOT CONSIDERED FINAL**  
**UNTIL ALL SIGNATURES ARE COMPLETED**

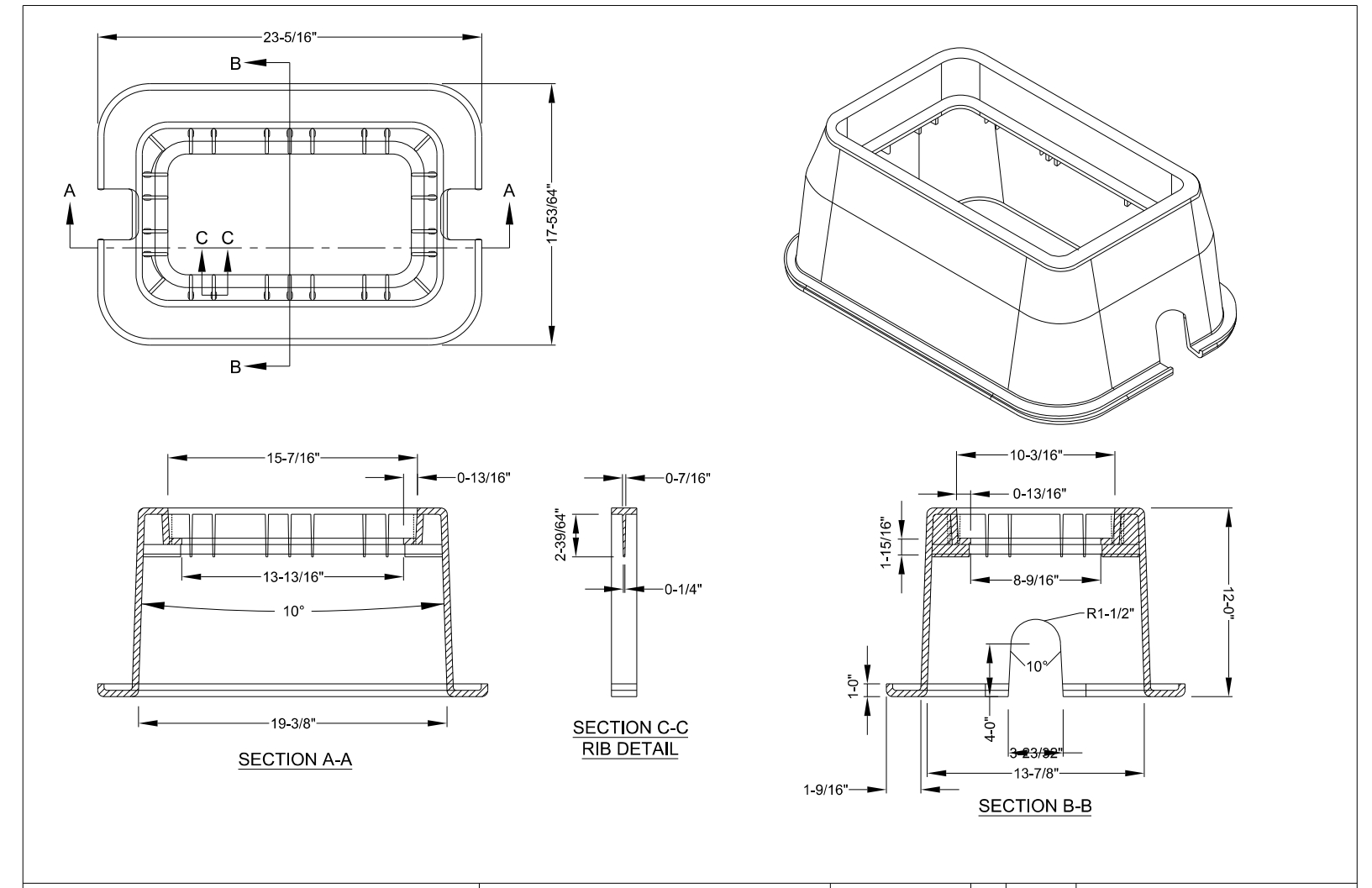

<b>1-INCH COMPOSITE METER BOX &amp; COVER</b> N.T.S.		<b>FAYETTEVILLE PUBLIC WORKS COMMISSION</b> FAYETTEVILLE, N.C.		<b>WATER RESOURCES DEPARTMENT</b>	
SHEET NO. 2 OF 2	DWG. NO. W.4B DATE: JAN. 01, 2021	DWG. BY: FAYPWC APPROVED BY: J.E.G.	<b>FWC</b>	NO. DATE REVISION 1 12/15 REPLACED CI BOX WITH COMPOSITE BOX	

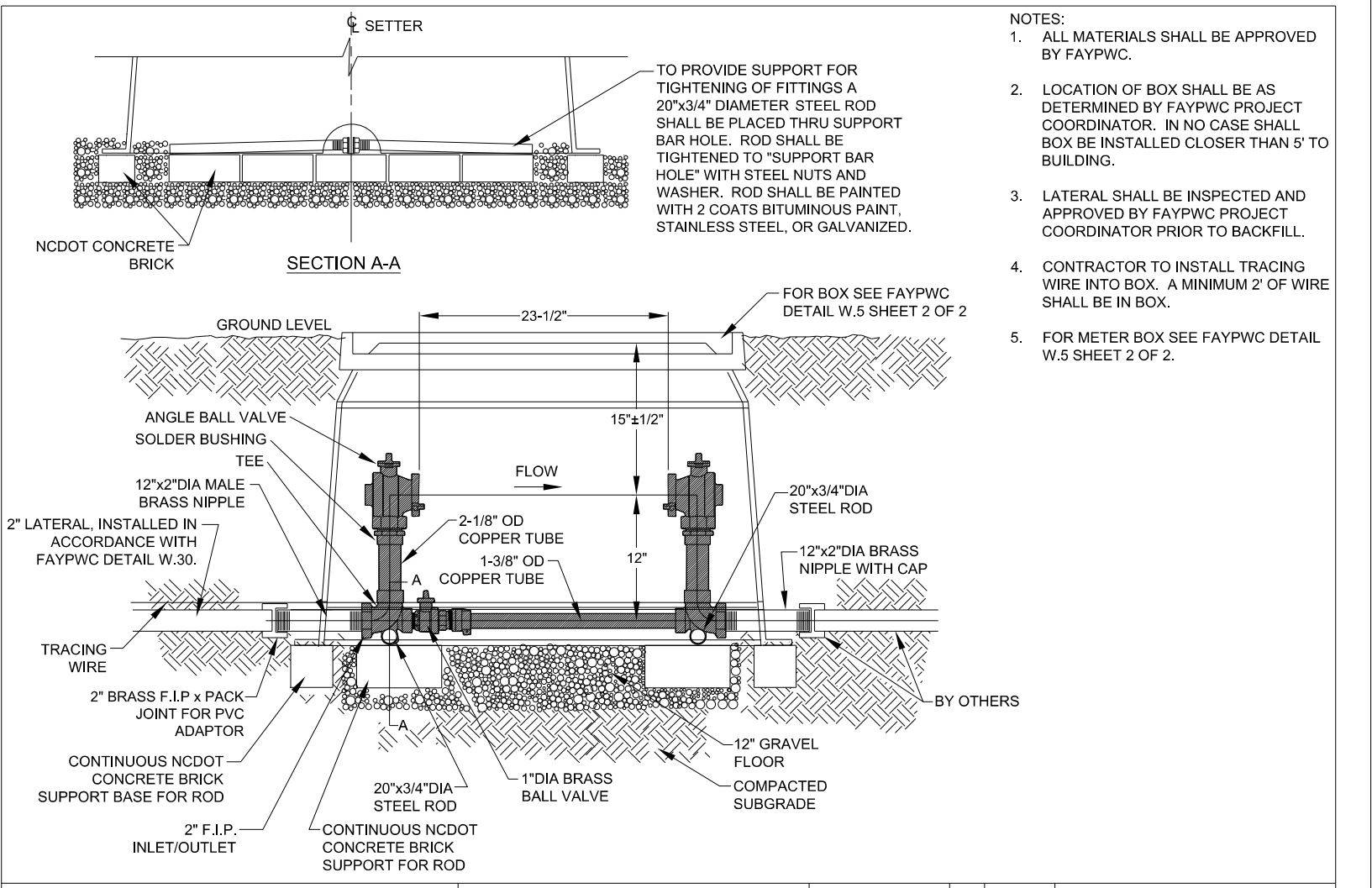

<b>2" COPPER SETTER WITH BY-PASS</b> 23-1/2" METER SPACING		<b>FAYETTEVILLE PUBLIC WORKS COMMISSION</b> FAYETTEVILLE, N.C.		<b>WATER RESOURCES DEPARTMENT</b>	
SHEET NO. 1 OF 2	DWG. NO. W.5 DATE: JAN. 01, 2021	DWG. BY: FAYPWC APPROVED BY: J.E.G.	<b>FWC</b>	NO. DATE REVISION 1 07/13 REVISED, UPDATED NOTES 2 07/17 UPDATED NOTES	

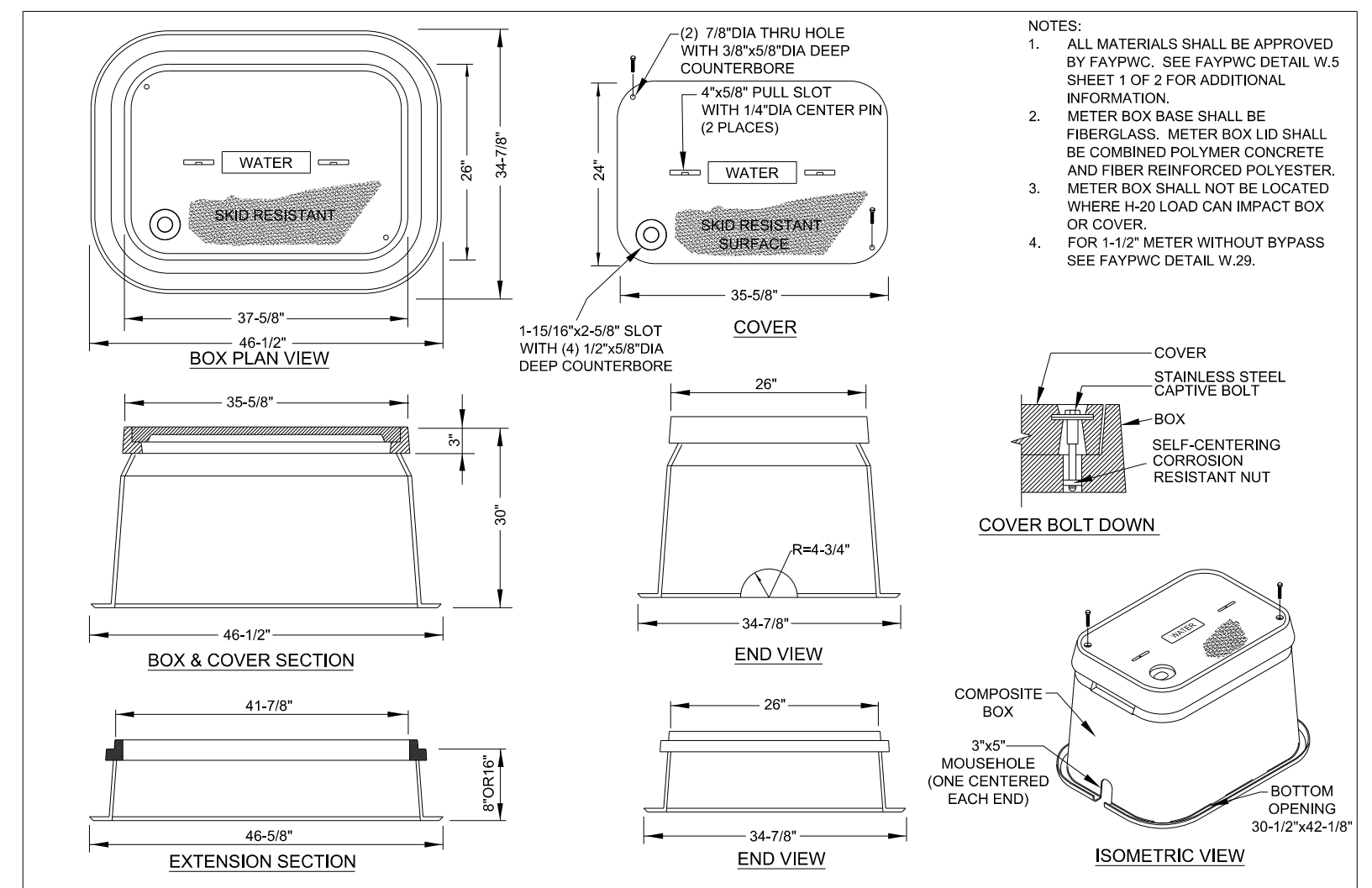

<b>1-1/2" AND 2" BY-PASS METER BOX</b> N.T.S.		<b>FAYETTEVILLE PUBLIC WORKS COMMISSION</b> FAYETTEVILLE, N.C.		<b>WATER RESOURCES DEPARTMENT</b>	
SHEET NO. 2 OF 2	DWG. NO. W.5 DATE: JAN. 01, 2021	DWG. BY: FAYPWC APPROVED BY: J.E.G.	<b>FWC</b>	NO. DATE REVISION 1 12/15 REVISED LID	

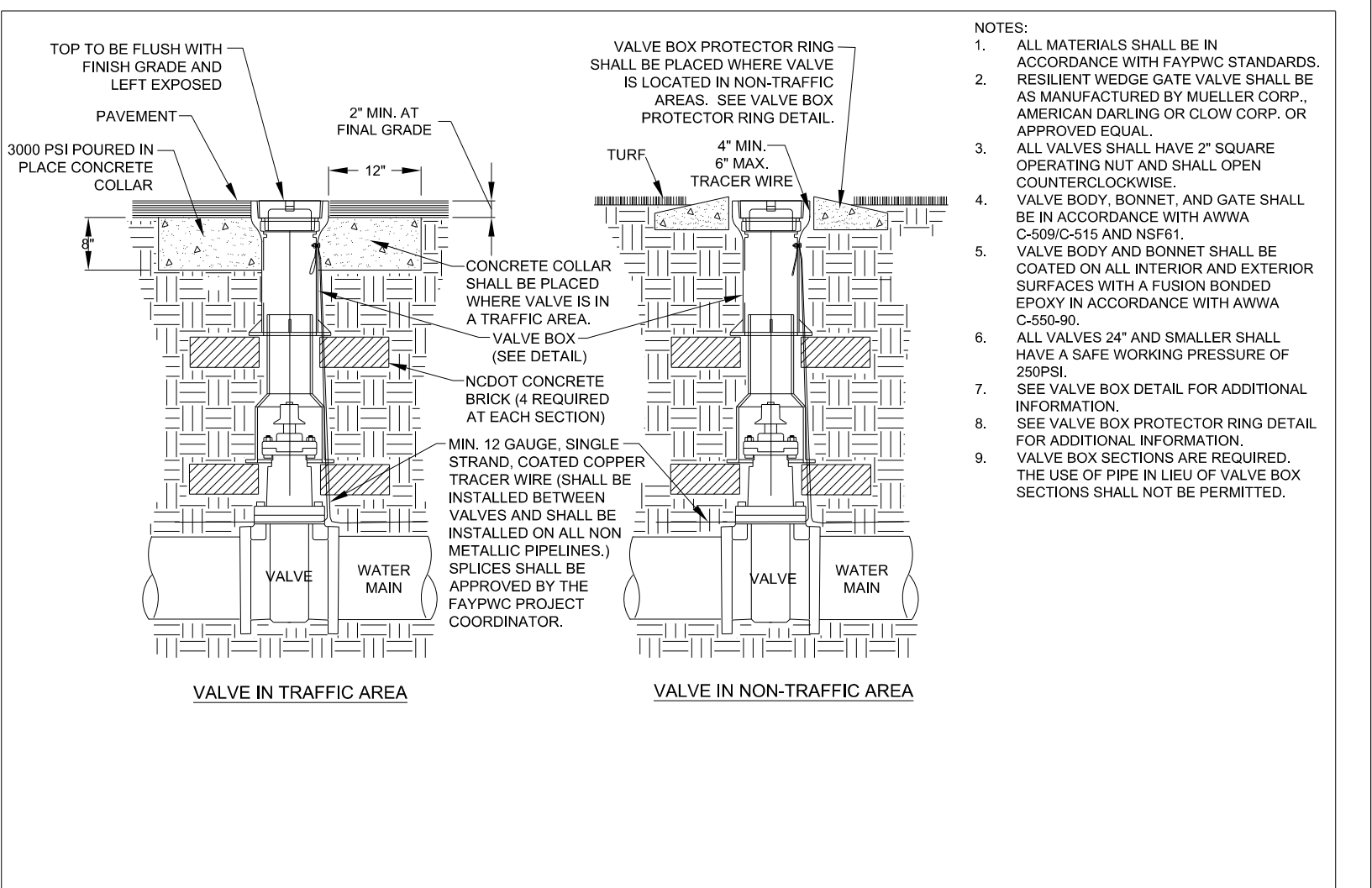

<b>GATE VALVE</b> N.T.S.		<b>FAYETTEVILLE PUBLIC WORKS COMMISSION</b> FAYETTEVILLE, N.C.		<b>WATER RESOURCES DEPARTMENT</b>	
SHEET NO. 1 OF 1	DWG. NO. W.6 DATE: JAN. 01, 2021	DWG. BY: FAYPWC APPROVED BY: J.E.G.	<b>FWC</b>	NO. DATE REVISION 1 8/06 ADDED NOTE NO. 9 2 7/09 CLARIFIED NOTES	

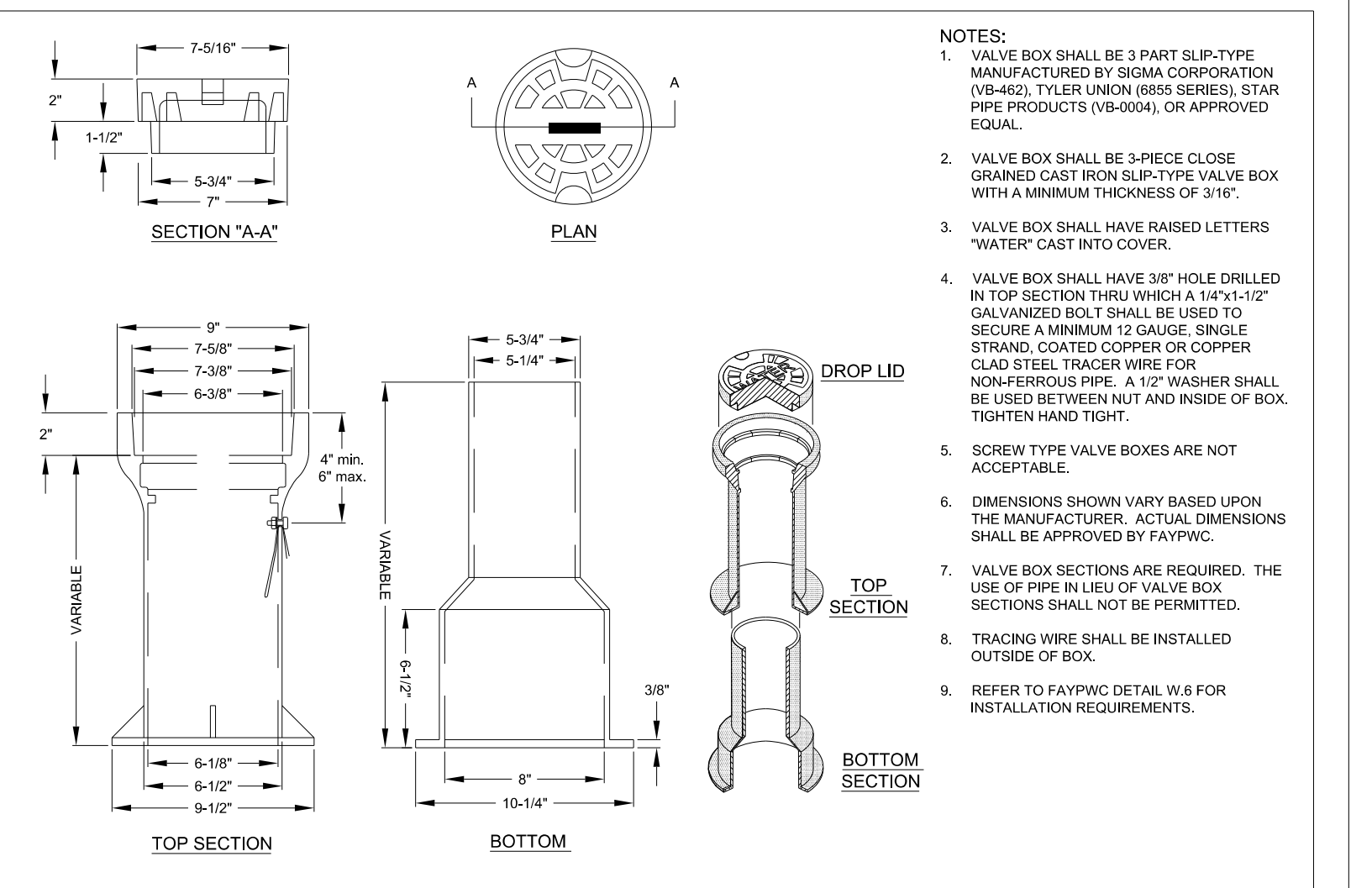

<b>VALVE BOX</b> N.T.S.		<b>FAYETTEVILLE PUBLIC WORKS COMMISSION</b> FAYETTEVILLE, N.C.		<b>WATER RESOURCES DEPARTMENT</b>	
SHEET NO. 1 OF 1	DWG. NO. W.7 DATE: JAN. 01, 2021	DWG. BY: FAYPWC APPROVED BY: J.E.G.	<b>FWC</b>	NO. DATE REVISION 1 07/09 ADDED NOTES 7, 8, AND CLARIFIED NOTES 2 01/14 REVISED NOTES 1, 4, 6	

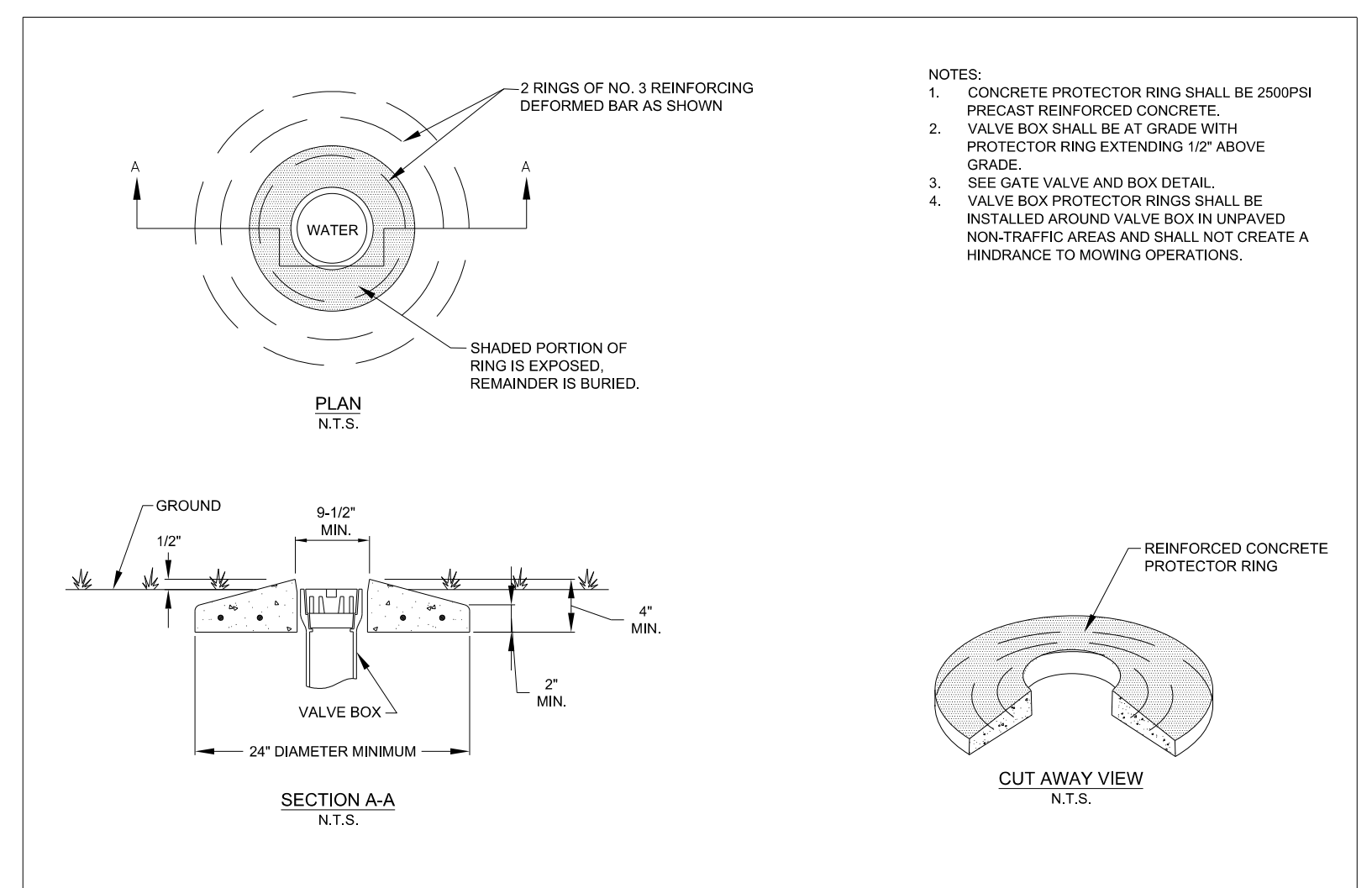

<b>VALVE BOX PROTECTOR RING</b> N.T.S.		<b>FAYETTEVILLE PUBLIC WORKS COMMISSION</b> FAYETTEVILLE, N.C.		<b>WATER RESOURCES DEPARTMENT</b>	
SHEET NO. 1 OF 1	DWG. NO. W.8 DATE: JAN. 01, 2021	DWG. BY: FAYPWC APPROVED BY: J.E.G.	<b>FWC</b>	NO. DATE REVISION	

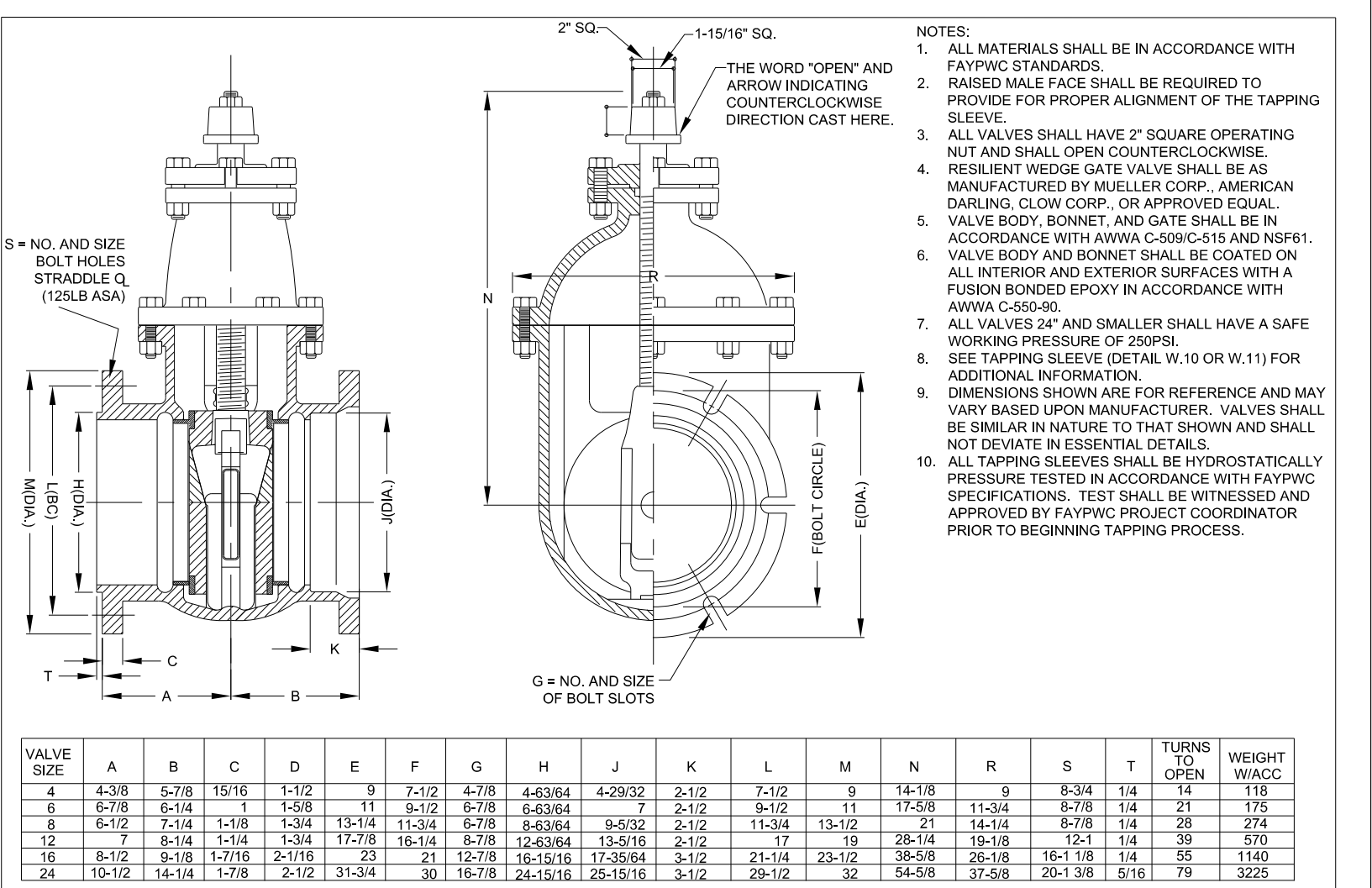

<b>TAPPING VALVE</b> N.T.S.		<b>FAYETTEVILLE PUBLIC WORKS COMMISSION</b> FAYETTEVILLE, N.C.		<b>WATER RESOURCES DEPARTMENT</b>	
SHEET NO. 1 OF 1	DWG. NO. W.9 DATE: JAN. 01, 2021	DWG. BY: FAYPWC APPROVED BY: J.E.G.	<b>FWC</b>	NO. DATE REVISION 1 07/09 ADDED NOTE 10, REVISED 4 AND 5 2 07/13 REVISED NOTES 4, 8, 10	

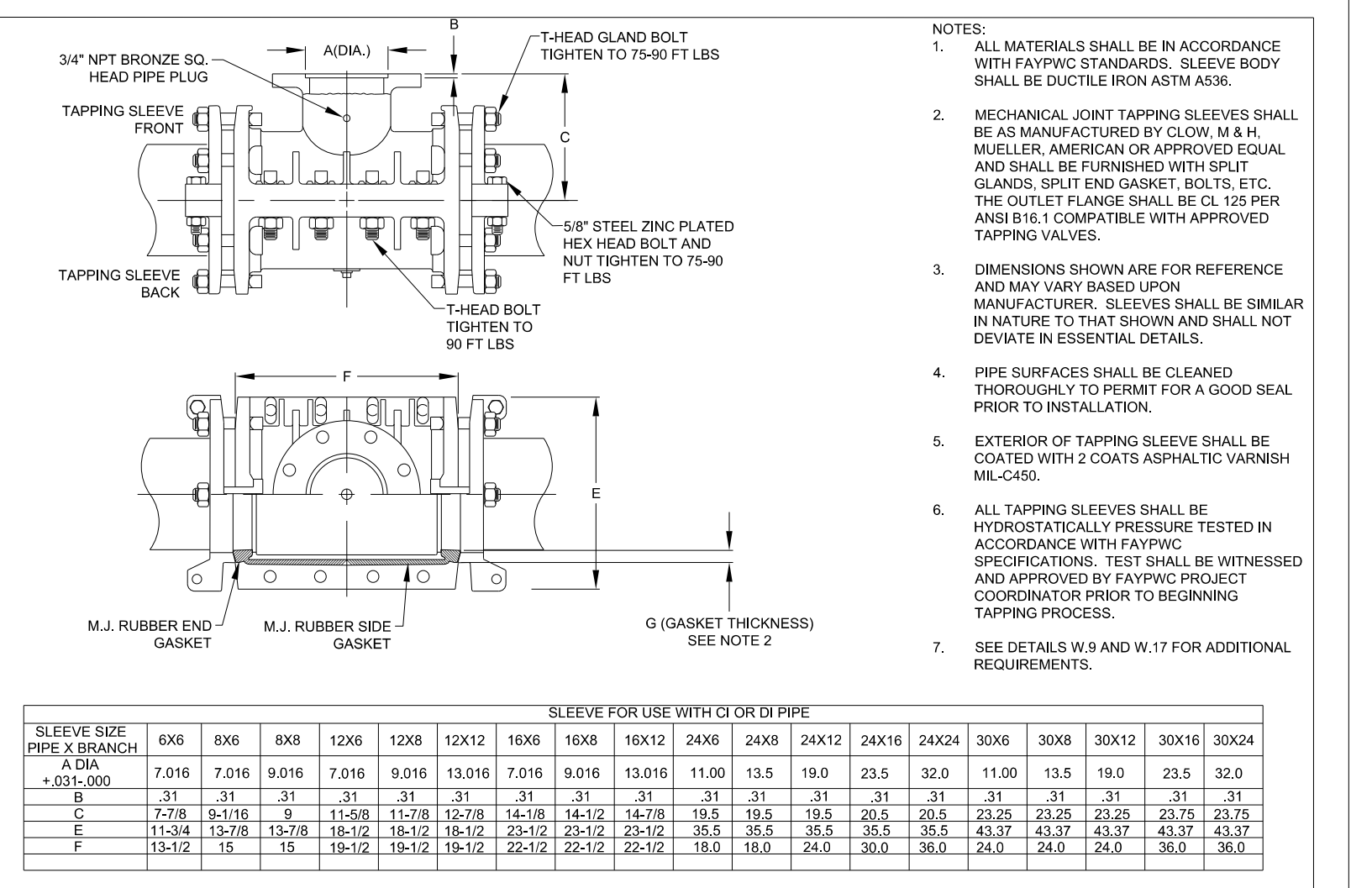

<b>DUCTILE IRON TAPPING SLEEVE</b> N.T.S.		<b>FAYETTEVILLE PUBLIC WORKS COMMISSION</b> FAYETTEVILLE, N.C.		<b>WATER RESOURCES DEPARTMENT</b>	
SHEET NO. 1 OF 1	DWG. NO. W.10 DATE: JAN. 01, 2021	DWG. BY: FAYPWC APPROVED BY: J.E.G.	<b>FWC</b>	NO. DATE REVISION 1 07/09 REVISION NOTE 10, REVISED 4 AND 5 2 07/13 REVISED NOTES 4, 6, 7	

01 OCT 2021 09:38:09 Environmental\Fayetteville Public Works Commission\2015017700RA - Reelford Road NCDOT U 4405\CADD\NCDOT PLANS\Utilities\Engineering\UC\Proc\U4405A\_ut\_dt\_UC03D\_psh.dgn  
 5/14/99  
 UTILITY REV. - JULY 24, 2008 - REVISIONS TO DETAIL SHEETS