



PROJECT REFERENCE NO. U-4405A	SHEET NO. 9
RW SHEET NO. U-4405 PSH 9	HYDRAULICS ENGINEER
ROADWAY DESIGN ENGINEER	SEAL 20147
 	
DOCUMENT NOT CONSIDERED FINAL UNLESS ALL SIGNATURES COMPLETED	

-L-
 Pls Sta 81+21.39 Pl Sta 84+71.94 Pls Sta 88+21.95
 Os = 0' 27' 17.0" Δ = 5' 45' 54.2" (RT) Os = 0' 27' 17.0"
 Ls = 100.00' D = 0' 54' 34.0" Ls = 100.00'
 LT = 66.67' L = 633.90' LT = 66.67'
 ST = 33.33' T = 317.22' ST = 33.33'
 R = 6,300.00'
 SE = 0.025

-Y5-
 Pl Sta 15+94.46
 Δ = 34' 10' 44.0" (RT)
 D = 10' 44' 58.8"
 L = 317.95'
 T = 163.86'
 R = 533.00'

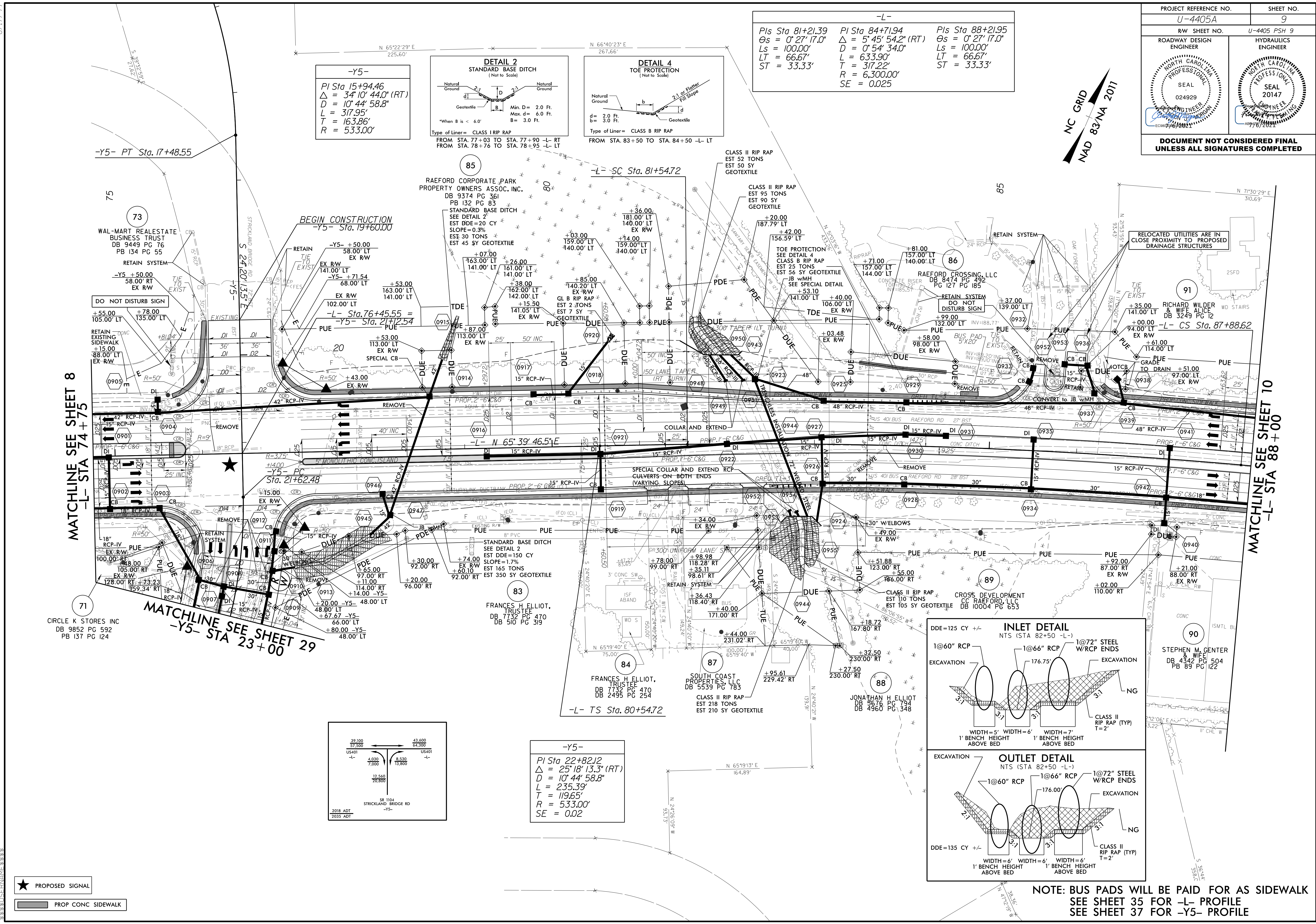
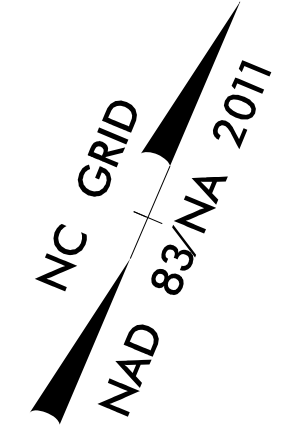
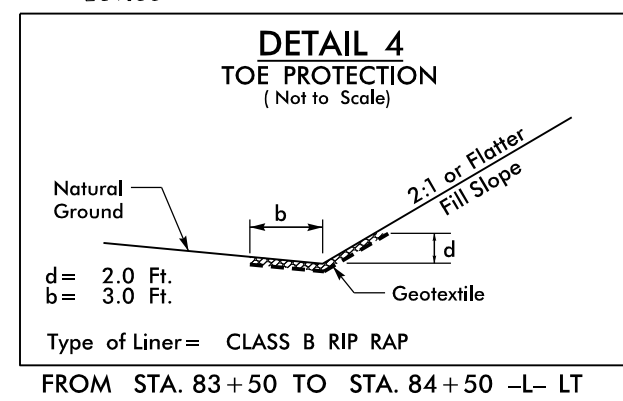
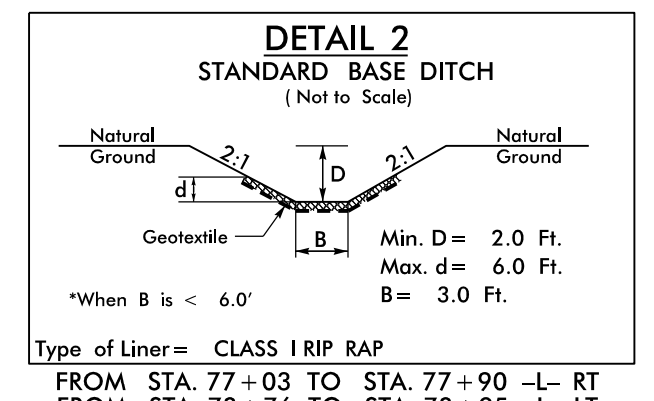

MATCHLINE SEE SHEET 8
-L- STA 74 + 75

MATCHLINE SEE SHEET 10
-L- STA 88 + 00

MATCHLINE SEE SHEET 29
-Y5- STA 23 + 00

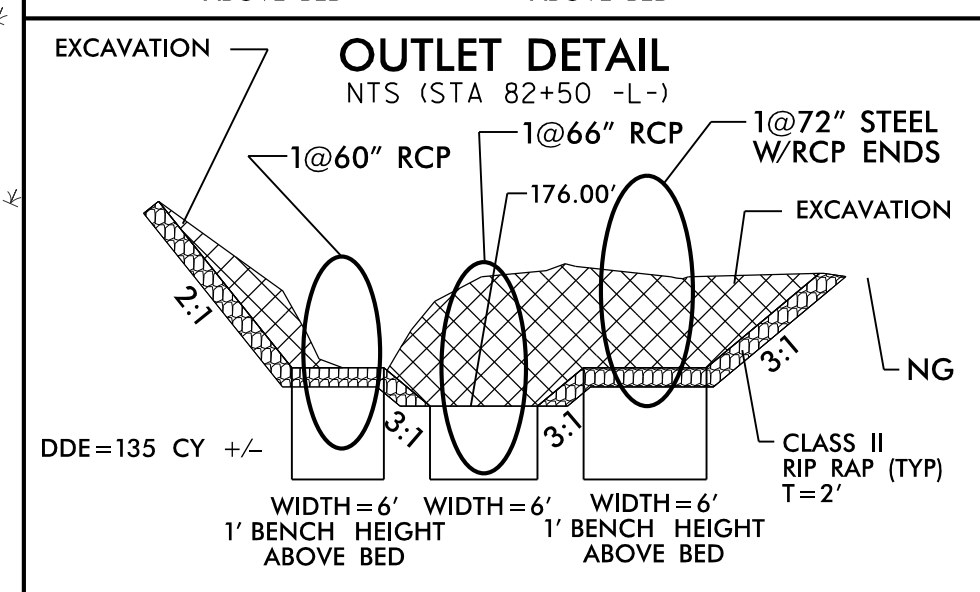
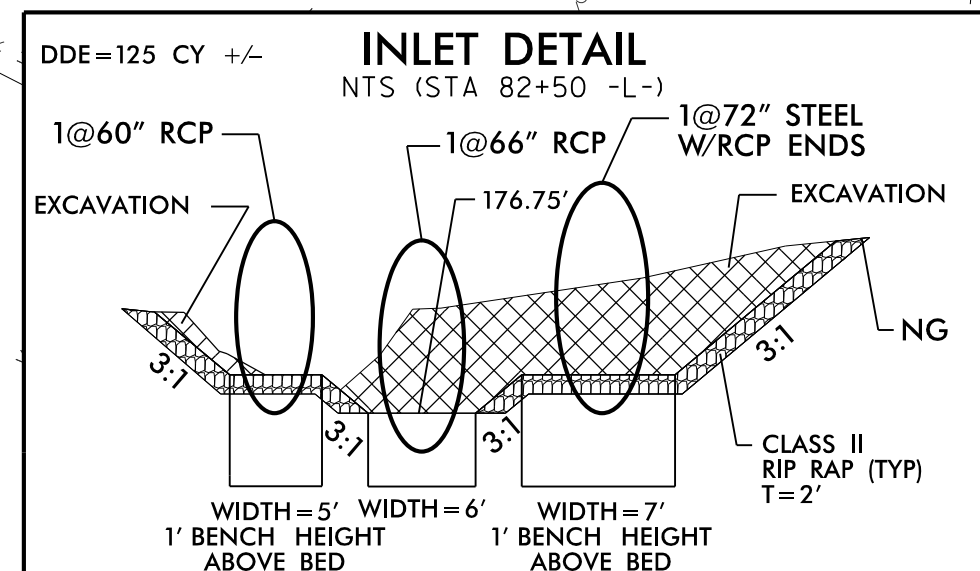

-Y5-
 Pl Sta 22+82.12
 Δ = 25' 18' 13.3" (RT)
 D = 10' 44' 58.8"
 L = 235.39'
 T = 119.65'
 R = 533.00'
 SE = 0.02

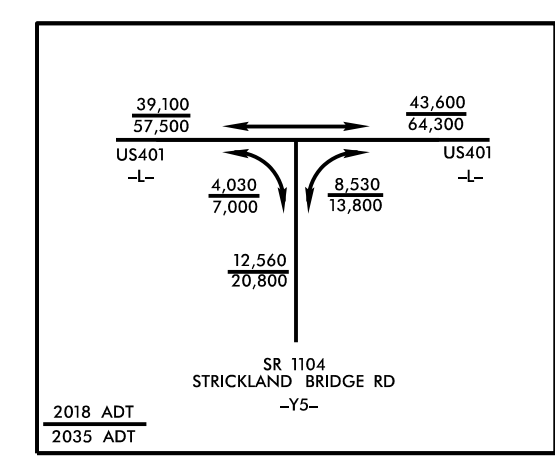

- ★ PROPOSED SIGNAL
- ▬ PROP CONC SIDEWALK

NOTE: BUS PADS WILL BE PAID FOR AS SIDEWALK
 SEE SHEET 35 FOR -L- PROFILE
 SEE SHEET 37 FOR -Y5- PROFILE

8.17.17.99
 02-JUL-2021 09:18
 R:\Projects\2021\1616\U-4405A_rdw_09.dgn
 \$\$\$\$\$\$DISPERNAME\$\$\$\$\$\$