

SECTION A-A
(EXISTING JOINT)

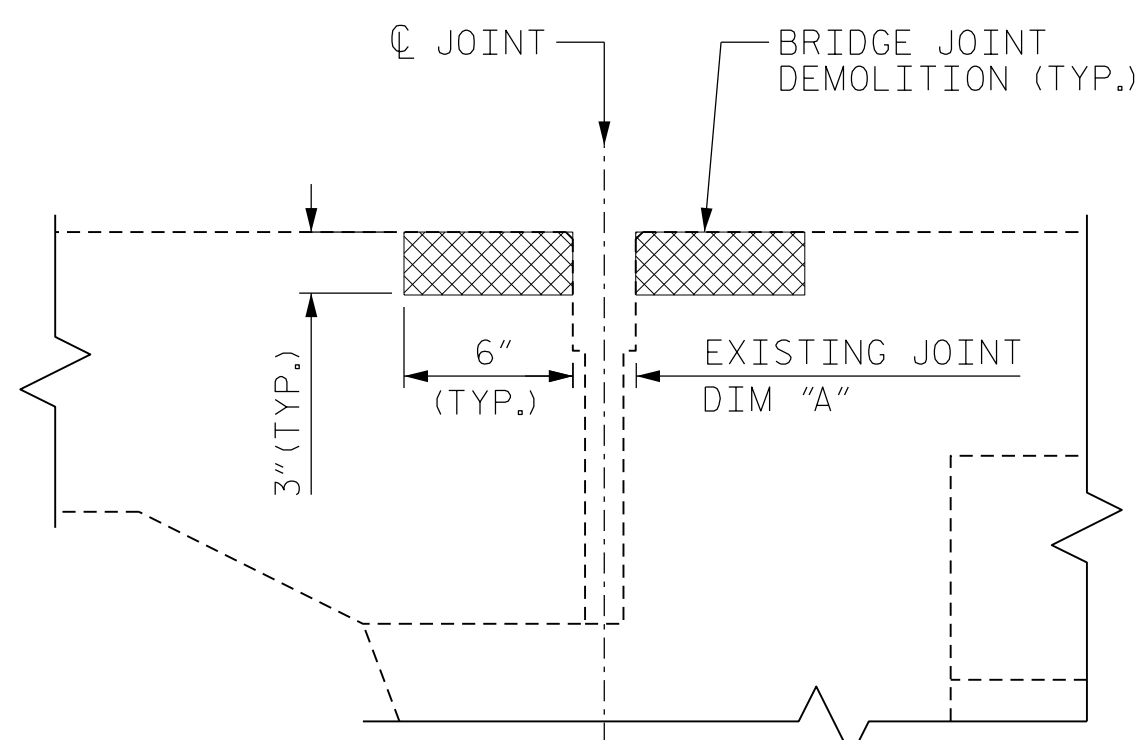

SECTION A-A
(MIN. DEMOLITION)

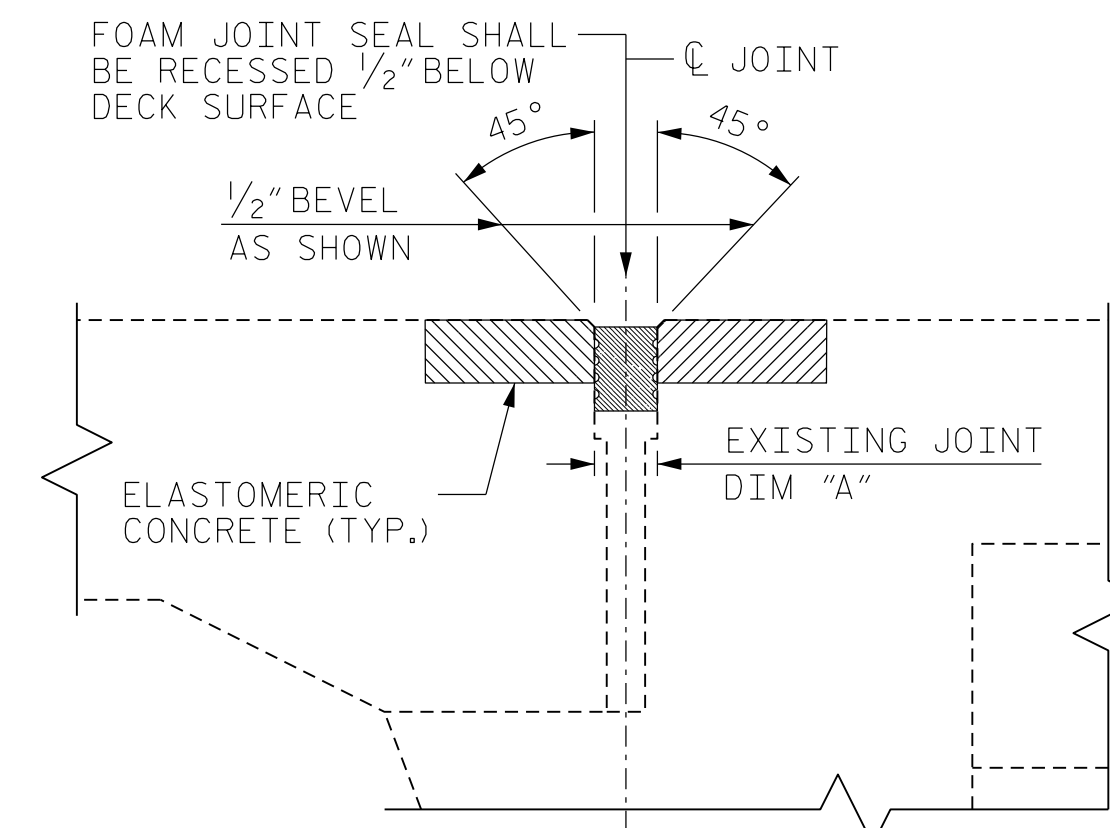

SECTION A-A
(PROPOSED JOINT)

NOTES:

THE CONTRACTOR SHALL FIELD VERIFY THE EXISTING JOINT OPENING PRIOR TO ORDERING JOINT SEAL MATERIAL. IF THE ACTUAL OPENING VARIES FROM THE OPENING INDICATED IN THE DETAIL BY MORE THAN 1/4", NOTIFY THE ENGINEER. REVISION OF THE JOINT SEAL SIZE MIGHT BE NECESSARY.

THE MANUFACTURER IS TO PROVIDE THE NOMINAL UNCOMPRESSED SEAL WIDTH OF THE FOAM JOINT SEAL FOR THE SIZE OF THE OPENING ON THE PLANS AND ACCOMMODATE THE MINIMUM EXPANSION SHOWN ON THE PLANS.

FOAM JOINTS SHALL BE INSTALLED AS PER THE MANUFACTURER'S RECOMMENDATIONS.

THE CONTRACTOR SHALL TAKE CARE DURING JOINT REHAB OPERATIONS NOT TO DROP ANY MATERIAL THAT FALLS BELOW THE BRIDGE, WITHOUT PROTECTIVE DEVICES BELOW TO CATCH THE MATERIAL. ANY MATERIAL THAT FALLS BELOW THE BRIDGE SHALL BE CONTAINED, REMOVED AND DISPOSED OF BY THE CONTRACTOR AT NO EXTRA COST TO THE DEPARTMENT. IF THE ENGINEER DETERMINES THAT THE PROTECTIVE DEVICES ARE NOT ADEQUATE OR NOT BEING EMPLOYED, THE WORK SHALL BE SUSPENDED UNTIL ADEQUATE PROTECTION IS PROVIDED.

THE CONTRACTOR WILL NOT BE PERMITTED TO FORM THE JOINTS IN LIEU OF SAWING THE JOINT.

THE INSTALLED FOAM JOINT SHALL BE WATER TIGHT.

QUANTITIES SHOWN IN THE ELASTOMERIC CONCRETE FOR PRESERVATION TABLE BASED ON THE MINIMUM JOINT DEMOLITION SHOWN.

FOR EXCAVATION BELOW THE BOTTOM OF THE PLANNED JOINT DECK DEMOLITION, CONCRETE FOR DECK REPAIRS SHALL BE PLACED IN THE EXCAVATED AREA TO THE ELEVATION AT BOTTOM OF THE PROPOSED ELASTOMERIC CONCRETE FOR PRESERVATION HEADERS SHOWN.

FOR BRIDGE JOINT DEMOLITION, SEE SPECIAL PROVISIONS.

FOR FOAM JOINT SEALS FOR PRESERVATION, SEE SPECIAL PROVISIONS.

FOR ELASTOMERIC CONCRETE FOR PRESERVATION, SEE SPECIAL PROVISIONS.

FOR CONCRETE FOR DECK REPAIR, SEE SPECIAL PROVISIONS.

IF THE EMBEDDED PORTION OF THE EXISTING PLASTIC WATERSTOP IS EXPOSED DURING REMOVAL OF UNSOUND CONCRETE, OR IF UNSOUND CONCRETE IS REMOVED WITHIN 2" OF THE WATERSTOP, THE ENTIRE CONCRETE DEPTH TO THE WATERSTOPS SHALL BE REMOVED. IF SUCH EXCAVATION EXTENDS MORE THAN 2" BELOW THE BOTTOM OF THE PLANNED ELASTOMERIC CONCRETE HEADER, AS SHOWN, APPROVED REPAIR CONCRETE SHALL BE PLACED IN THE EXCAVATED AREA TO THE ELEVATION AT THE BOTTOM OF THE ELASTOMERIC CONCRETE.

DEMOLISH BRIDGE JOINT AREA SUCH THAT THE BOTTOM OF THE EXCAVATION SHALL BE REASONABLY FLAT AND LEVEL AND TO THE NECESSARY DEPTH, SUCH THAT ELASTOMERIC CONCRETE SHALL BE FOUNDED ON CONCRETE OR REPAIR CONCRETE SUBSTRATE.

TABLE 1	
Table Date 04-2021	
BENT/ JOINTS	DIM "A" @ 71°F
END BENT 1	2"
1	N/A
2	N/A
3	N/A
END BENT 2	2"

ELASTOMERIC CONCRETE FOR PRESERVATION		
LOCATION	ESTIMATED (CU.FT.)	ACTUAL (CU.FT.)
END BENTS	20.0	
BENT 1	N/A	
BENT 2	N/A	
BENT 3	N/A	

BRIDGE JOINT DEMOLITION		
LOCATION	ESTIMATED (SQ.FT.)	ACTUAL (SQ.FT.)
END BENTS	80	
BENT 1	N/A	
BENT 2	N/A	
BENT 3	N/A	

PROPOSED JOINT QUANTITY		
	ESTIMATED (LIN.FT.)	ACTUAL (LIN.FT.)
FOAM JOINT SEALS FOR PRESERVATION	84	

PROJECT NO. I-5939
ROBESON COUNTY
 BRIDGE NO. 770106

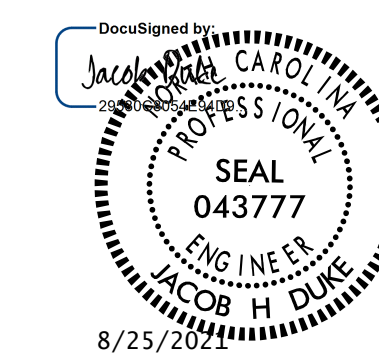

KCA
KISINGER CAMPO & ASSOCIATES
 301 FAYETTEVILLE ST., SUITE 1500
 RALEIGH, NC 27601 (919) 882-7839
 NC FIRM LICENSE: C-1506

STATE OF NORTH CAROLINA
 DEPARTMENT OF TRANSPORTATION
 RALEIGH

JOINT DETAILS

DRAWN BY : DIEGO A. AGUIRRE DATE : 06/2021
 CHECKED BY : FIDEL L. FLORES DATE : 06/2021
 DESIGN ENGINEER OF RECORD: JACOB H. DUKE DATE : 06/2021

8/25/2021
 I9939.SMU.JT01.770106.dgn
 fflores

DOCUMENT NOT CONSIDERED
 FINAL UNLESS ALL
 SIGNATURES COMPLETED

REVISIONS						SHEET NO.
NO.	BY:	DATE:	NO.	BY:	DATE:	
1			3			S10-4
2			4			TOTAL SHEETS 5