

AS-BUILT REPAIR QUANTITY TABLE

TOP OF DECK REPAIRS

	SPAN 1		SPAN 2		SPAN 3		SPAN 4	
	ESTIMATE	ACTUAL	ESTIMATE	ACTUAL	ESTIMATE	ACTUAL	ESTIMATE	ACTUAL
CONCRETE DECK REPAIR FOR EPOXY OVERLAY	0.0 SF		0.0 SF		0.0 SF		0.0 SF	
EPOXY OVERLAY SYSTEM II	2102 SF		6128 SF		6128 SF		2130 SF	
SHOTCRETE REPAIR AREA (SCR)	-- CF		0.5 CF		-- CF		-- CF	

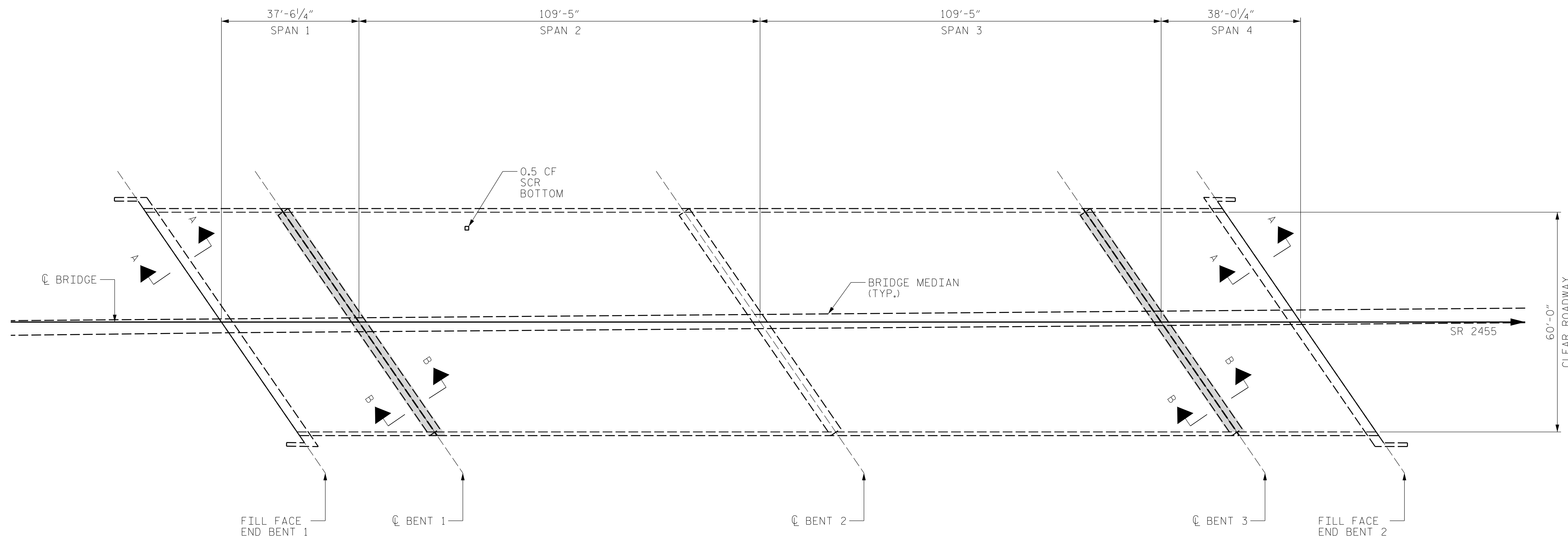

PROJECT NO. I-5939
ROBESON COUNTY
 BRIDGE NO. 770104

NOTES:

REPAIR LOCATIONS AND ESTIMATED QUANTITIES ARE GIVEN WITH THE BEST INFORMATION AVAILABLE. IF ADDITIONAL REPAIRS NOT SHOWN ON THE DRAWINGS ARE DEEMED NECESSARY BY THE ENGINEER, THE ENGINEER WILL NOTE ON THE DRAWINGS THE APPROXIMATE LOCATIONS AND DESCRIPTION OF THE REPAIRS AND ADJUST THE ACTUAL QUANTITIES ENTERED INTO THE AS-BUILT REPAIR QUANTITY TABLE.

EPOXY OVERLAY LIMITS EXCLUDE THE BRIDGE MEDIAN, FOR LIMITS, SEE TYPICAL SECTION SHEET

EPOXY OVERLAY

BRIDGE JOINT DEMOLITION

SHOTCRETE REPAIR AREA (SCR)

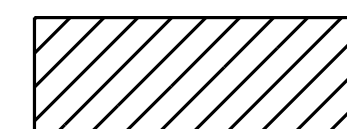

DRAWN BY : ALLEN J. MCSWAIN DATE : 06/2021
 CHECKED BY : DIEGO A. AGUIRRE DATE : 06/2021
 DESIGN ENGINEER OF RECORD: JACOB H. DUKE DATE : 06/2021

8/25/2021
 I5939.SMU.DSR01.770104.dgn
 fflores

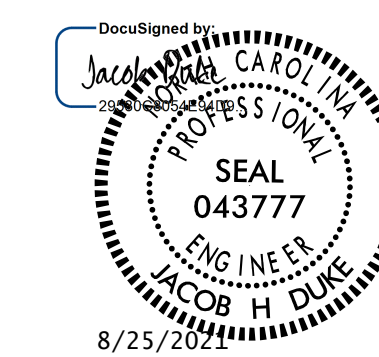

KCA
KISINGER CAMPO & ASSOCIATES
 301 FAYETTEVILLE ST., SUITE 1500
 RALEIGH, NC 27601 (919) 882-7839
 NC FIRM LICENSE: C-1506

STATE OF NORTH CAROLINA
 DEPARTMENT OF TRANSPORTATION
 RALEIGH

PLAN OF SPANS

DOCUMENT NOT CONSIDERED FINAL UNLESS ALL SIGNATURES COMPLETED

REVISIONS						SHEET NO.
NO.	BY:	DATE:	NO.	BY:	DATE:	
1			3			S9-3
2			4			TOTAL SHEETS 10