

PROJECT REFERENCE NO. 15614.1075010	SHEET NO. 7
RW SHEET NO.	
ROADWAY DESIGN ENGINEER	HYDRAULICS ENGINEER
DOCUMENT NOT CONSIDERED FINAL UNLESS ALL SIGNATURES COMPLETED	
<b>TGS ENGINEERS</b> 804-C N. LAFAYETTE ST SHELBY, NC 28150 PH: (704) 476-0003 CORP. LICENSE NO.: C-0275	

**-I26- CURVE DATA**

PIs Sta 477+79.15 θs = 8° 00' 00.0" Ls = 400.00' LT = 266.94' ST = 133.58'	PI Sta 479+97.10 Δ = 6° 47' 00.0" (RT) D = 4° 00' 00.0" L = 169.58' T = 84.89' R = 1,432.39'	PIs Sta 482+15.38 θs = 8° 00' 00.0" Ls = 400.00' LT = 266.94' ST = 133.58'	PIs Sta 487+91.25 θs = 4° 30' 00.0" Ls = 300.00' LT = 200.06' ST = 100.06'
--	---	--	--

**-HGR- CURVE DATA**

PI Sta 61+19.38 Δ = 9° 40' 19.5" (LT) D = 3° 53' 51.6" L = 248.15' T = 124.37' R = 1,470.00'	PI Sta 66+64.68 Δ = 26° 18' 14.6" (RT) D = 4° 22' 25.4" L = 601.41' T = 306.10' R = 1,310.00'	PI Sta 71+11.33 Δ = 10° 00' 42.7" (LT) D = 19° 05' 54.9" L = 52.42' T = 26.28' R = 300.00'	PI Sta 71+73.19 Δ = 39° 18' 35.0" (LT) D = 57° 17' 44.8" L = 68.61' T = 35.72' R = 100.00'
---	--	---	---



MATCH LINE STA. -126- 475 + 00 MATCH LINE STA. -HGR- 58 + 70  
 MATCH TO SHEET NO. 6 MATCH TO SHEET NO. 6

REVISIONS  
 08/17/99  
 07/17/2021 X:\NCDD01-1-26 Howard Gap Rd Rehab\Roadway\Proj\1-26-Howard Gap\_Rdy\_psh\_07.dgn  
 User:cmbeck

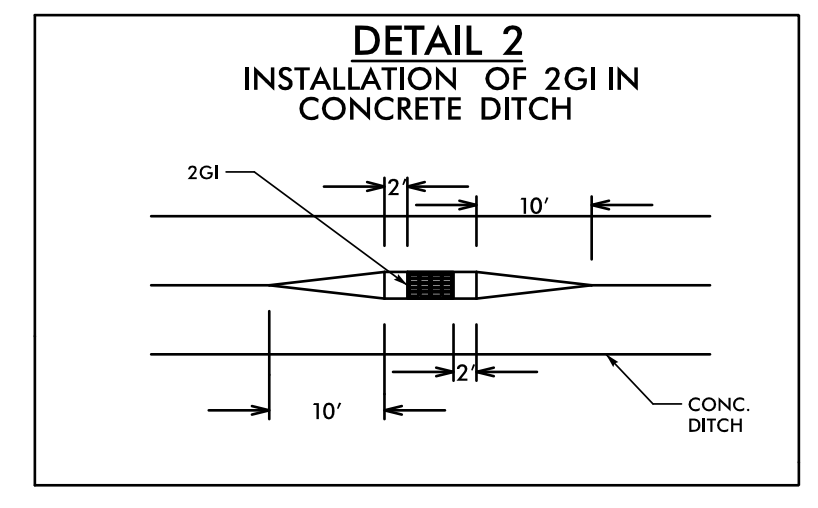
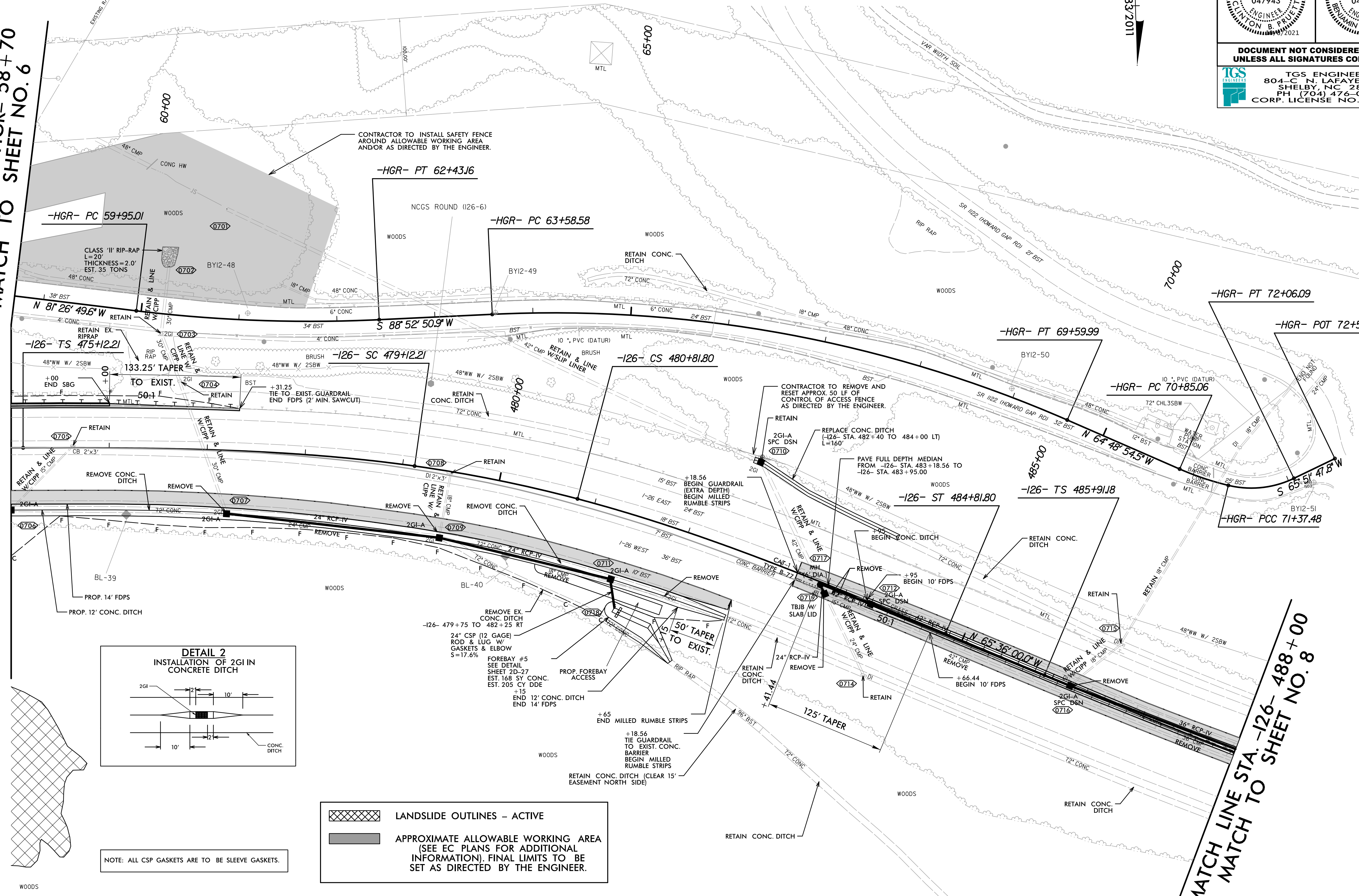

NOTE: ALL CSP GASKETS ARE TO BE SLEEVE GASKETS.

	LANDSLIDE OUTLINES - ACTIVE
	APPROXIMATE ALLOWABLE WORKING AREA (SEE EC PLANS FOR ADDITIONAL INFORMATION). FINAL LIMITS TO BE SET AS DIRECTED BY THE ENGINEER.