

PLAN

NOTES

- STIRRUPS IN CAP MAY BE SHIFTED AS NECESSARY TO CLEAR DOWELS.
- THE CONCRETE IN THE SHADED AREA OF THE WING SHALL BE POURED AFTER THE VERTICAL CONCRETE BARRIER RAIL IS CAST IF SLIP FORMING IS USED.
- FOR PILE SPLICE DETAILS, SEE SHEET 4 OF 4.
- FOR WING DETAILS, SEE SHEET 3 OF 4.

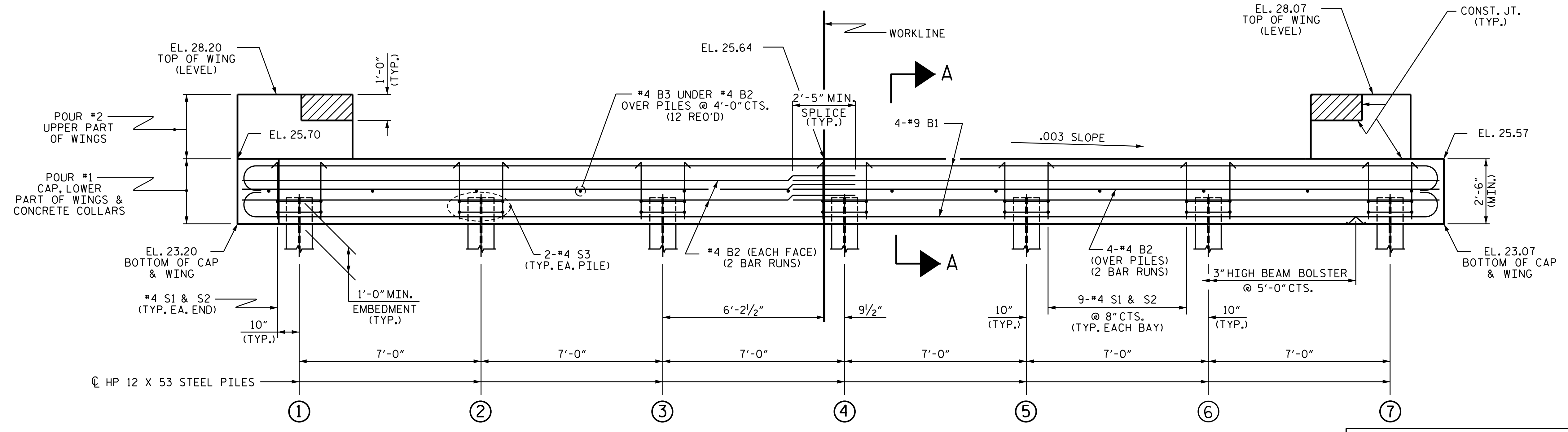

ELEVATION

TOP OF PILE ELEVATIONS	
①	24.20
②	24.18
③	24.16
④	24.14
⑤	24.12
⑥	24.10
⑦	24.08

PROJECT NO. 17BP.2.R.92  
 PITT COUNTY  
 STATION: 13+78.50 -L-

SHEET 2 OF 4

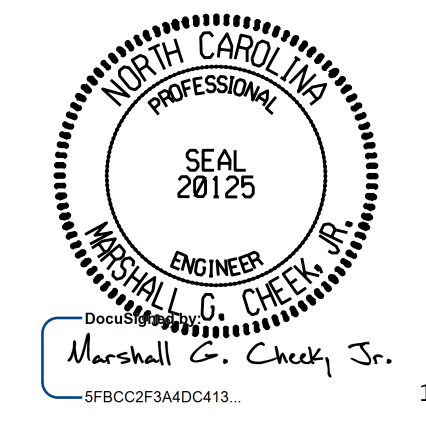

STATE OF NORTH CAROLINA  
 DEPARTMENT OF TRANSPORTATION  
 RALEIGH  
 SUBSTRUCTURE  
 END BENT No. 2

WINGS NOT SHOWN FOR CLARITY.  
 FOR SECTION A-A, SEE SHEET 4 OF 4.  
 CONCRETE COLLARS FOR STEEL PILES NOT SHOWN IN PLAN AND ELEVATION VIEWS FOR CLARITY.  
 SEE "CORROSION PROTECTION FOR STEEL PILES DETAIL", SHEET 4 OF 4.

ASSEMBLED BY : ZCS	DATE : 06/19
CHECKED BY : MGC	DATE : 09/19
DRAWN BY : DGE 01/10	REV. 4/15
CHECKED BY : MKT 01/10	MAA/TMG

DOCUMENT NOT CONSIDERED FINAL  
 UNLESS ALL SIGNATURES COMPLETED

TGS ENGINEERS  
 706 HILLSBOROUGH STREET  
 SUITE 200  
 RALEIGH, NC 27603  
 PH (919) 773-8887  
 CORP. LICENSE NO.: C-0275

REVISIONS						SHEET NO.
NO.	BY:	DATE:	NO.	BY:	DATE:	S-12
1			3			TOTAL SHEETS
2			4			19