

AS-BUILT REPAIR QUANTITY TABLE

BENT 11	QUANTITIES			
	ESTIMATE		ACTUAL	
SHOTCRETE REPAIRS	AREA SO. FT.	VOLUME CU. FT.	AREA SO. FT.	VOLUME CU. FT.
CAP	67.0	33.5		
COLUMNS & STRUTS	19.9	10.0		
CONCRETE REPAIRS	AREA SO. FT.	VOLUME CU. FT.	AREA SO. FT.	VOLUME CU. FT.
CAP	10.5	5.3		
EPOXY RESIN INJECTION		LIN. FT.		LIN. FT.
CAP		0.0		
COLUMNS & STRUTS		0.0		
EPOXY COATING		SO. FT.		SO. FT.
TOP OF BENT CAP & STRUTS		208		

VALUES IN CHART REPRESENT ESTIMATED REPAIR TOTALS AFTER REMOVAL OF UNSOUND CONCRETE, MIN. OF 1" BEHIND REBAR AND 2" MIN. CLEAR TO SAWCUT. FOR REPAIR DETAILS, SEE "TYPICAL CAP AND COLUMN REPAIR DETAILS" SHEET.

NOTES

REPAIR LOCATIONS AND ESTIMATE OF QUANTITIES ARE BASED ON THE BEST INFORMATION AVAILABLE. IF ADDITIONAL REPAIRS NOT SHOWN ON THE DRAWINGS ARE DEEMED NECESSARY BY THE ENGINEER, THE ENGINEER WILL NOTE ON THE DRAWINGS THE APPROXIMATE LOCATIONS AND DESCRIPTION OF THE REPAIRS AND ENTER THE ACTUAL QUANTITIES INTO THE AS-BUILT REPAIR QUANTITY TABLE.



CONCRETE REPAIRS MAY BE SUBSTITUTED IN LIEU OF SHOTCRETE REPAIRS WITH THE APPROVAL OF THE ENGINEER.

FOR SHOTCRETE REPAIR, SEE SPECIAL PROVISIONS.

FOR CONCRETE REPAIR, SEE SPECIAL PROVISIONS.

FOR EPOXY RESIN INJECTION, SEE SPECIAL PROVISIONS.

CLEAN AND REMOVE DEBRIS FROM THE TOP OF THE CAP AND STRUTS AND APPLY EPOXY PROTECTIVE COATING. EPOXY COATING SHALL BE APPLIED TO THE TOP SURFACE OF THE CAP AND STRUTS. THE CONTRACTOR SHALL NOT COAT THE AREA OF THE CAP BENEATH THE MASONRY PLATES. FOR EPOXY COATING, SEE SPECIAL PROVISIONS.

-  SHOTCRETE REPAIR AREA
-  CONCRETE REPAIR AREA
-  EPOXY RESIN INJECTION (ERI)

PROJECT NO. I-5746C
MECKLENBURG COUNTY
 BRIDGE NO: 590332

SHEET 3 OF 6

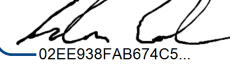
DocuSigned by:

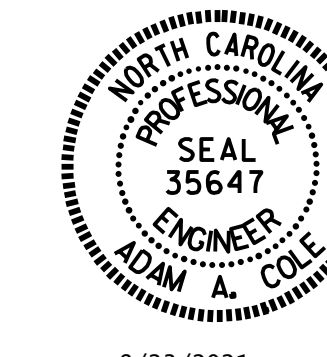
 GLENN ABRAYAC



STATE OF NORTH CAROLINA
 DEPARTMENT OF TRANSPORTATION
 RALEIGH

BENT 11
 SPAN L FACE

REVISIONS

NO.	BY:	DATE:	NO.	BY:	DATE:	SHEET NO.
1			3			S10-77
2			4			TOTAL SHEETS 274

DOCUMENT NOT CONSIDERED
 FINAL UNLESS ALL
 SIGNATURES COMPLETED

MATCHLINE



TOP OF CAP

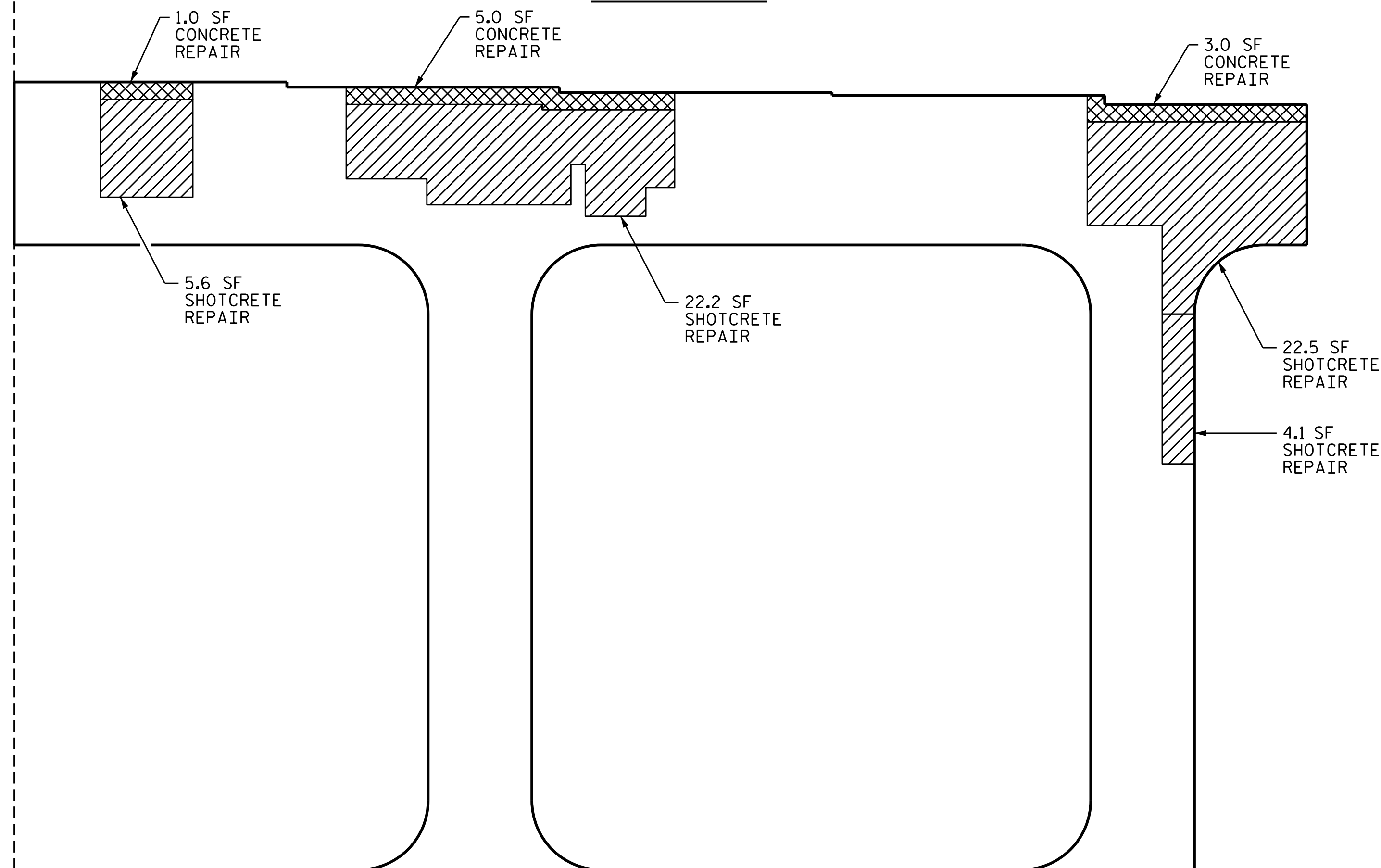

SPAN L SPAN M

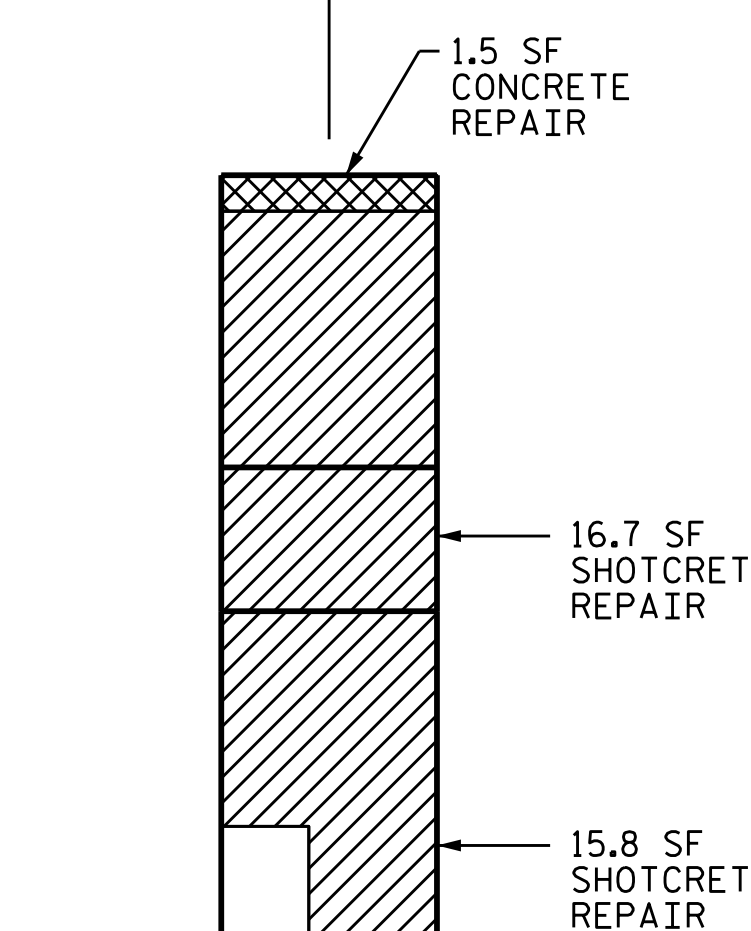

APPROXIMATE GROUND LINE

ELEVATION
 BENT 11

END VIEW

DRAWN BY : R.L. PUTEK DATE : 06/2021
 CHECKED BY : H. A. LOCKLEAR DATE : 06/2021