

NOTES

REPAIR LOCATIONS AND ESTIMATE OF QUANTITIES ARE BASED ON THE BEST INFORMATION AVAILABLE. IF ADDITIONAL REPAIRS NOT SHOWN ON THE DRAWINGS ARE DEEMED NECESSARY BY THE ENGINEER, THE ENGINEER WILL NOTE ON THE DRAWINGS THE APPROXIMATE LOCATIONS AND DESCRIPTION OF THE REPAIRS AND ENTER THE ACTUAL QUANTITIES INTO THE AS-BUILT REPAIR QUANTITY TABLE.



CONCRETE REPAIRS MAY BE SUBSTITUTED IN LIEU OF SHOTCRETE REPAIRS WITH THE APPROVAL OF THE ENGINEER.

FOR SHOTCRETE REPAIR, SEE SPECIAL PROVISIONS.

FOR CONCRETE REPAIR, SEE SPECIAL PROVISIONS.

FOR EPOXY RESIN INJECTION, SEE SPECIAL PROVISIONS.

CLEAN AND REMOVE DEBRIS FROM THE TOP OF THE CAP AND APPLY EPOXY PROTECTIVE COATING. EPOXY COATING SHALL BE APPLIED TO THE TOP SURFACE OF THE CAP. THE CONTRACTOR SHALL NOT COAT THE AREA OF THE CAP BENEATH THE MASONRY PLATES. FOR EPOXY COATING, SEE SPECIAL PROVISIONS.

-  SHOTCRETE REPAIR AREA
-  CONCRETE REPAIR AREA
-  EPOXY RESIN INJECTION (ERI)

AS-BUILT REPAIR QUANTITY TABLE				
BENT 3	QUANTITIES			
	ESTIMATE		ACTUAL	
SHOTCRETE REPAIRS	AREA SO. FT.	VOLUME CU. FT.	AREA SO. FT.	VOLUME CU. FT.
CAP	4.9	2.5		
COLUMNS	35.4	17.7		
CONCRETE REPAIRS	AREA SO. FT.	VOLUME CU. FT.	AREA SO. FT.	VOLUME CU. FT.
CAP	6.9	3.5		
EPOXY RESIN INJECTION		LIN. FT		LIN. FT
CAP		25.0		
COLUMNS		0.0		
EPOXY COATING		SO. FT.		SO. FT.
TOP OF BENT CAP		251		

VALUES IN CHART REPRESENT ESTIMATED REPAIR TOTALS AFTER REMOVAL OF UNSOUND CONCRETE, MIN. OF 1" BEHIND REBAR AND 2" MIN. CLEAR TO SAWCUT. FOR REPAIR DETAILS, SEE "TYPICAL CAP AND COLUMN REPAIR DETAILS" SHEET.

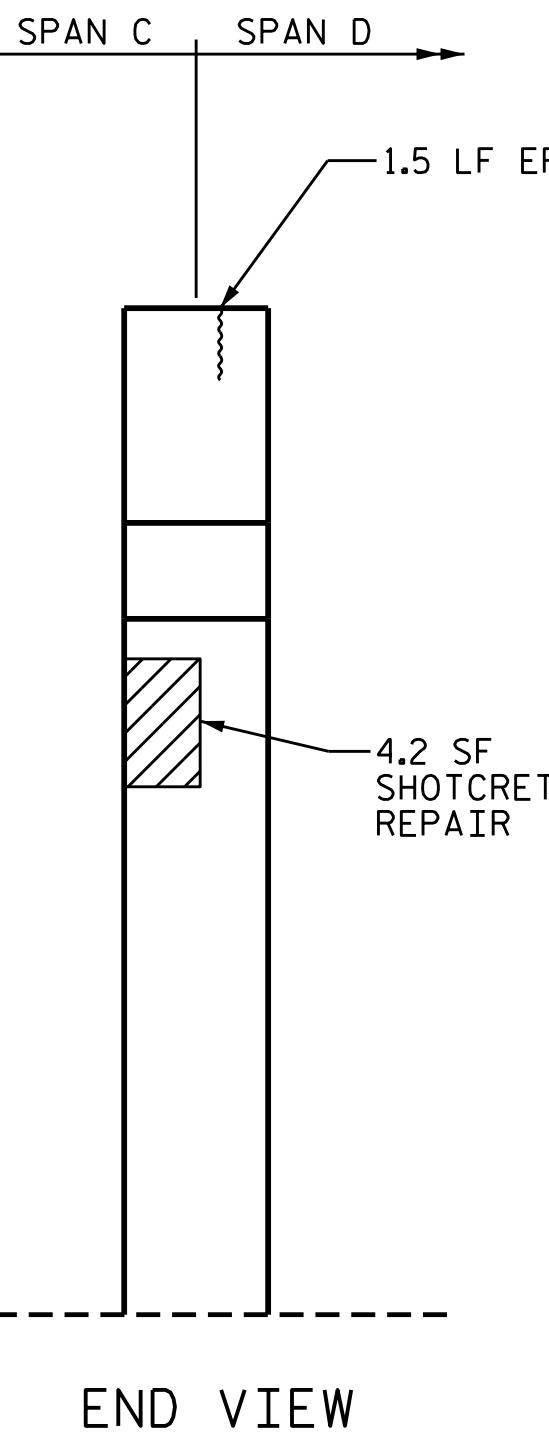
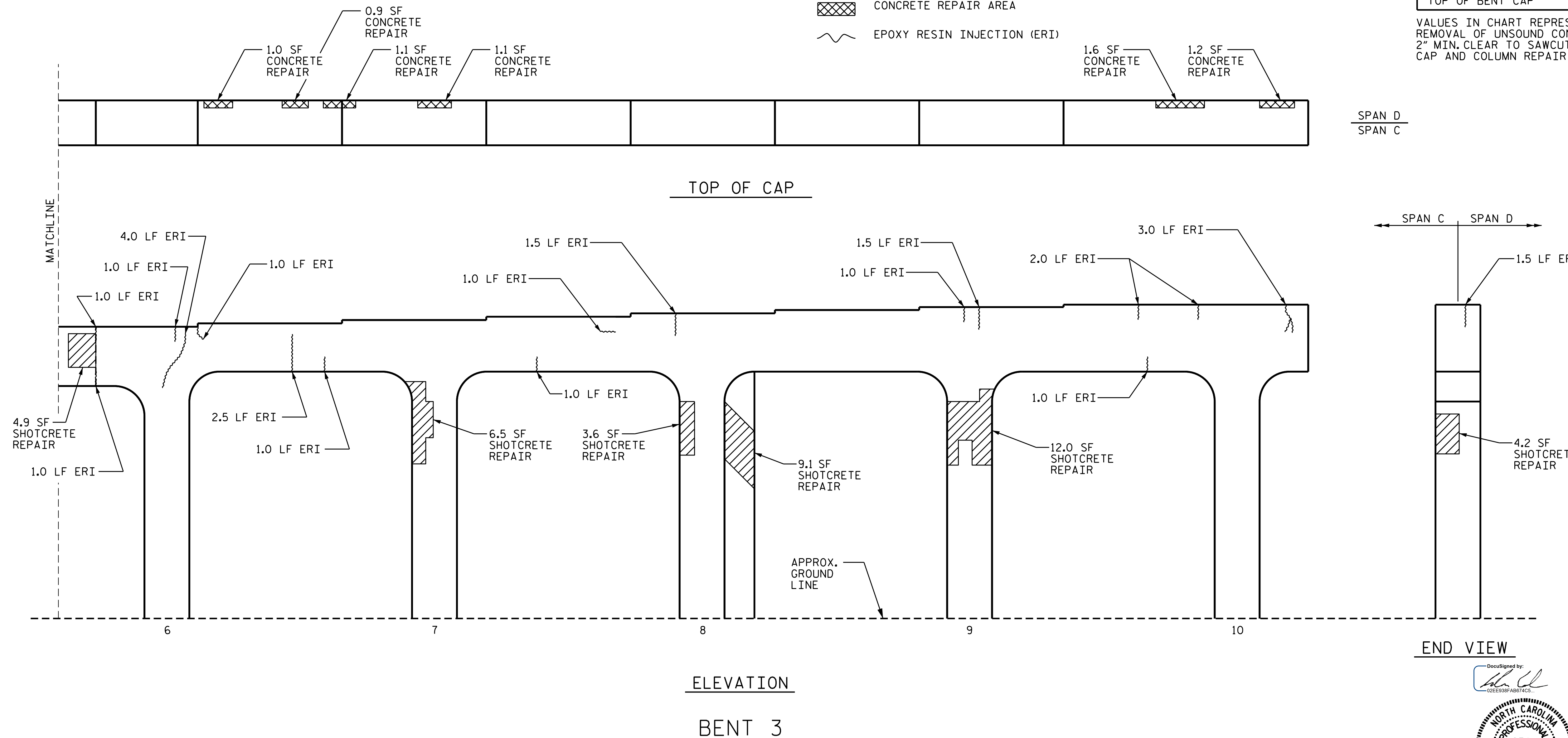

PROJECT NO. I-5746C
MECKLENBURG COUNTY
 BRIDGE NO. 590332

SHEET 2 OF 4

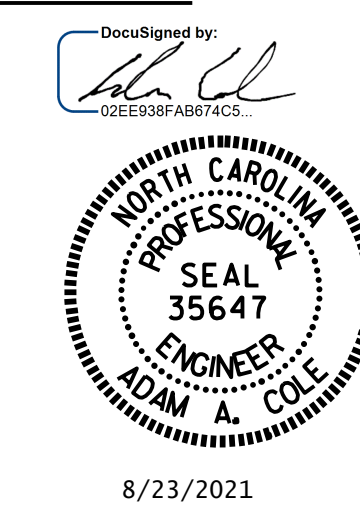

STATE OF NORTH CAROLINA
 DEPARTMENT OF TRANSPORTATION
 RALEIGH
BENT 3
SPAN C FACE

DRAWN BY : R.L. PUTTEK DATE : 06/2021
 CHECKED BY : H.A. LOCKLEAR DATE : 06/2021

NO.	REVISIONS			SHEET NO.
	BY:	DATE:	NO.	
1			3	S10-40 TOTAL SHEETS 274
2			4	

DOCUMENT NOT CONSIDERED
 FINAL UNLESS ALL
 SIGNATURES COMPLETED