

AS-BUILT REPAIR QUANTITY TABLE

BENT 5 CAP	QUANTITIES			
	ESTIMATE		ACTUAL	
SHOTCRETE REPAIRS	AREA SQ. FT.	VOLUME CU. FT.	AREA SQ. FT.	VOLUME CU. FT.
	CAP	14.3	7.2	
COLUMN	8.0	2.7		
CONCRETE REPAIRS	AREA SQ. FT.	VOLUME CU. FT.	AREA SQ. FT.	VOLUME CU. FT.
	CAP	12.0	6.0	
EPOXY RESIN INJECTION				
CAP	LIN. FT.		LIN. FT.	
COLUMN	0.0			
EPOXY COATING				
CAP	AREA SQ. FT.		AREA SQ. FT.	
	135			

VALUES IN CHART REPRESENT ESTIMATED REPAIR TOTALS AFTER REMOVAL OF UNSOUND CONCRETE, MINIMUM OF 1" BEHIND REBAR AND MINIMUM 2" CLEARANCE TO SAWCUT. FOR REPAIR DETAILS, SEE "TYPICAL CAP AND COLUMN REPAIR DETAILS" SHEET.

NOTES

REPAIR LOCATIONS AND ESTIMATE OF QUANTITIES ARE BASED ON THE BEST INFORMATION AVAILABLE. IF ADDITIONAL REPAIRS NOT SHOWN ON THE DRAWINGS ARE DEEMED NECESSARY BY THE ENGINEER, THE ENGINEER WILL NOTE ON THE DRAWINGS THE APPROXIMATE LOCATION AND DESCRIPTION OF THE REPAIRS AND ENTER THE ACTUAL QUANTITIES INTO THE AS-BUILT REPAIR QUANTITY TABLE.



CONCRETE REPAIRS MAY BE SUBSTITUTED IN LIEU OF SHOTCRETE REPAIRS WITH THE APPROVAL OF THE ENGINEER.

FOR CAP REPAIRS, SEE "TYPICAL CAP AND COLUMN REPAIR DETAILS" SHEETS.

FOR SHOTCRETE REPAIRS, SEE SPECIAL PROVISIONS.

FOR CONCRETE REPAIRS, SEE SPECIAL PROVISIONS.

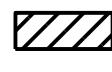
CLEAN AND REMOVE DEBRIS FROM THE TOP OF THE CAP AND APPLY EPOXY PROTECTIVE COATING. EPOXY COATING SHALL BE APPLIED TO THE TOP SURFACE OF THE CAP. THE CONTRACTOR SHALL NOT COAT THE AREA OF THE CAP BENEATH THE MASONRY PLATES. FOR EPOXY COATING, SEE SPECIAL PROVISIONS.

-  CONCRETE REPAIR AREA
-  SHOTCRETE REPAIR AREA
-  EPOXY RESIN INJECTION (ERI)

PEDESTAL WALL REPAIR, SEE "TYPICAL CAP AND COLUMN REPAIR DETAILS" SHEETS.

DocuSigned by:
02E539FAB014CS...



8/23/2021

PROJECT NO. I-5746C
MECKLENBURG COUNTY
 BRIDGE NO. 590044

STATE OF NORTH CAROLINA
 DEPARTMENT OF TRANSPORTATION
 RALEIGH

BENT 5

REVISIONS						SHEET NO.
NO.	BY:	DATE:	NO.	BY:	DATE:	SHEET NO.
1			3			S1-16
2			4			TOTAL SHEETS 274

DOCUMENT NOT CONSIDERED FINAL UNLESS ALL SIGNATURES COMPLETED

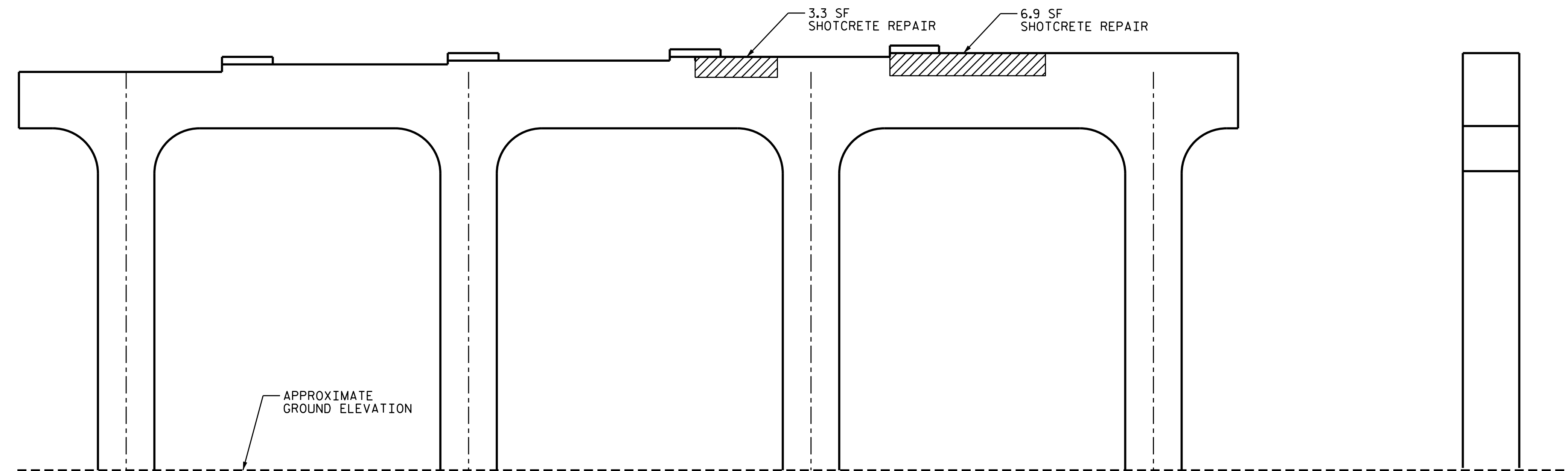
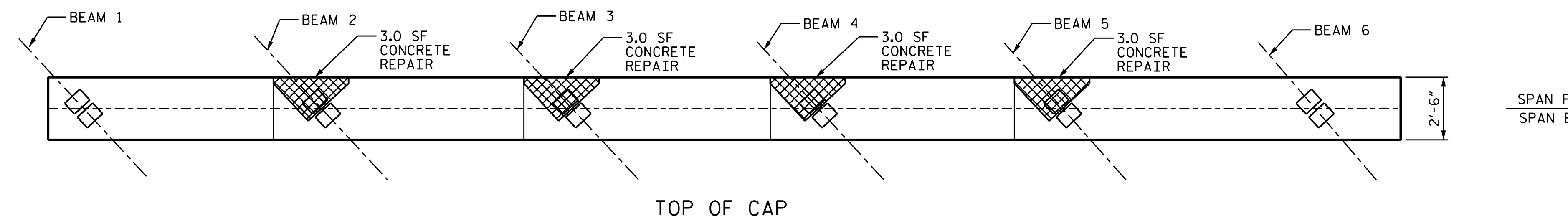

ELEVATION
SPAN E FACE

END VIEW



BOTTOM OF CAP

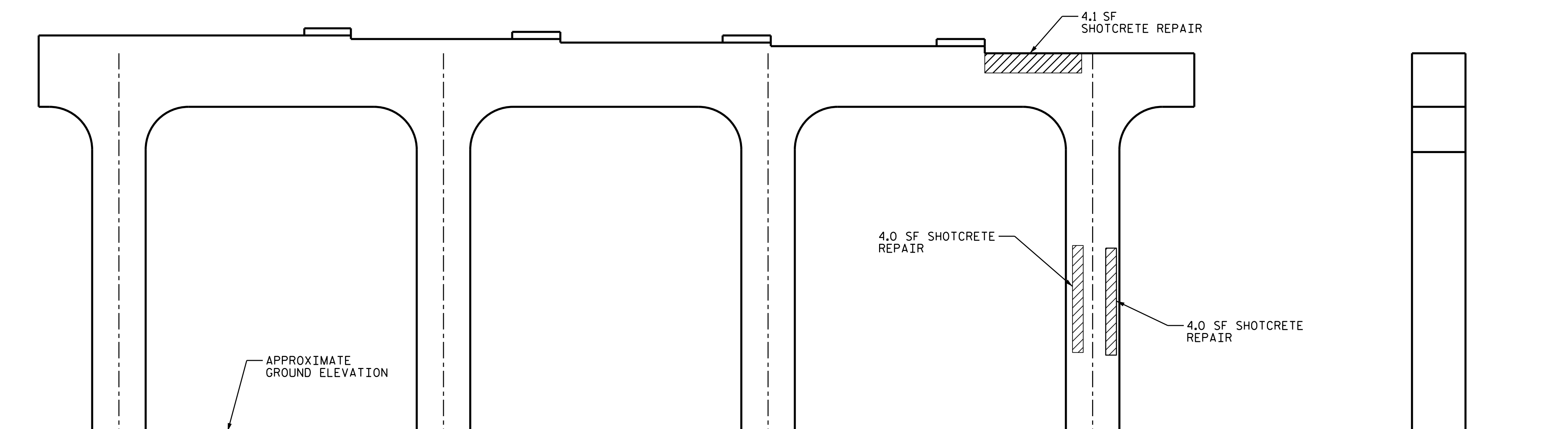

ELEVATION
SPAN F FACE

END VIEW

DRAWN BY : REZA KOUCHEKI DATE : .05/2021
 CHECKED BY : ASRA YASMEEN DATE : .05/2021