

PROJECT REFERENCE NO.	
I-5746C	EC-3
RW SHEET NO.	
ROADWAY DESIGN ENGINEER	HYDRAULICS ENGINEER

ONSITE CONCRETE WASHOUT STRUCTURE WITH LINER

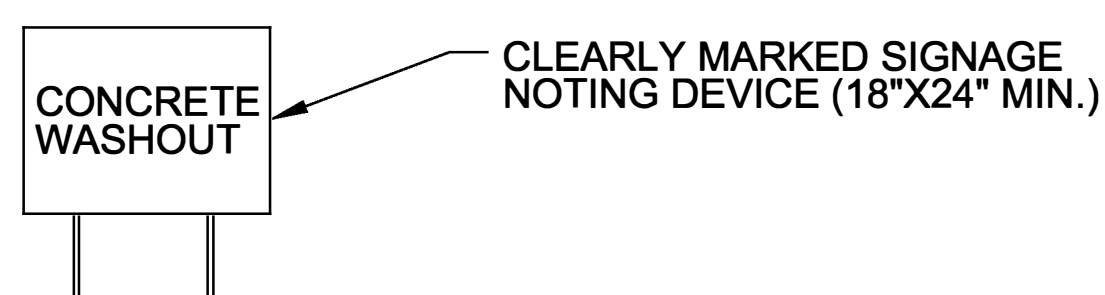
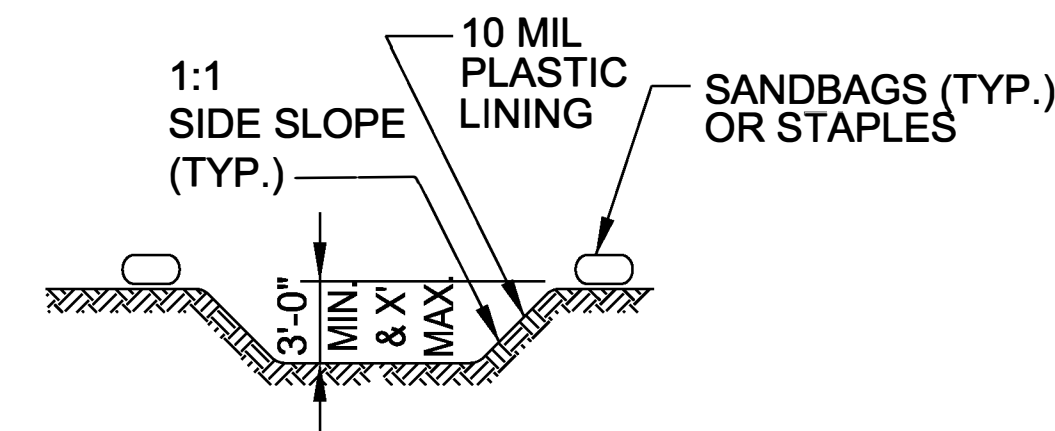
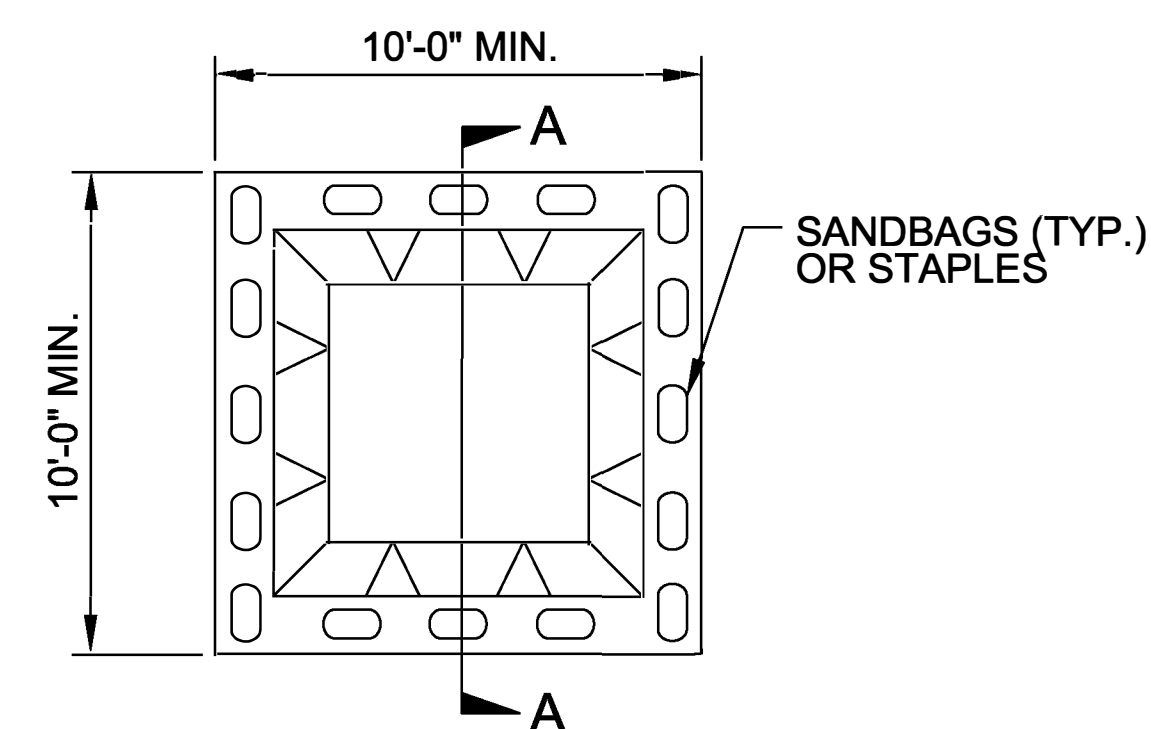

SECTION A-A

NOTES:

1. ACTUAL LOCATION DETERMINED IN FIELD
2. THE CONCRETE WASHOUT STRUCTURES SHALL BE MAINTAINED WHEN THE LIQUID AND/OR SOLID REACHES 75% OF THE STRUCTURES CAPACITY.
3. CONCRETE WASHOUT STRUCTURE NEEDS TO BE CLEARLY MARKED WITH SIGNAGE NOTING DEVICE.

PLAN

BELOW GRADE WASHOUT STRUCTURE

NOT TO SCALE

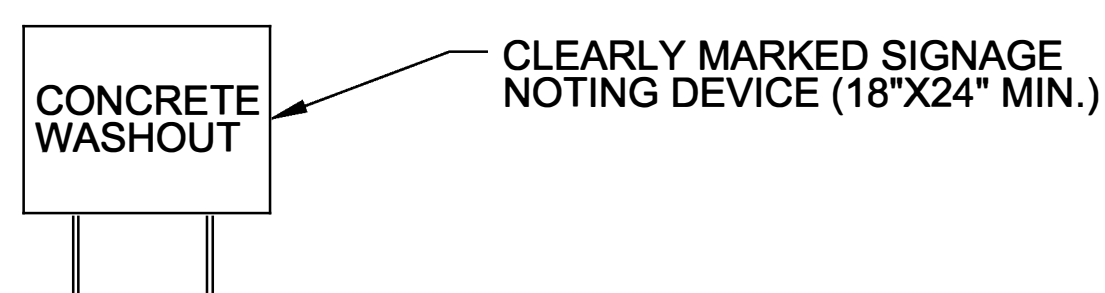
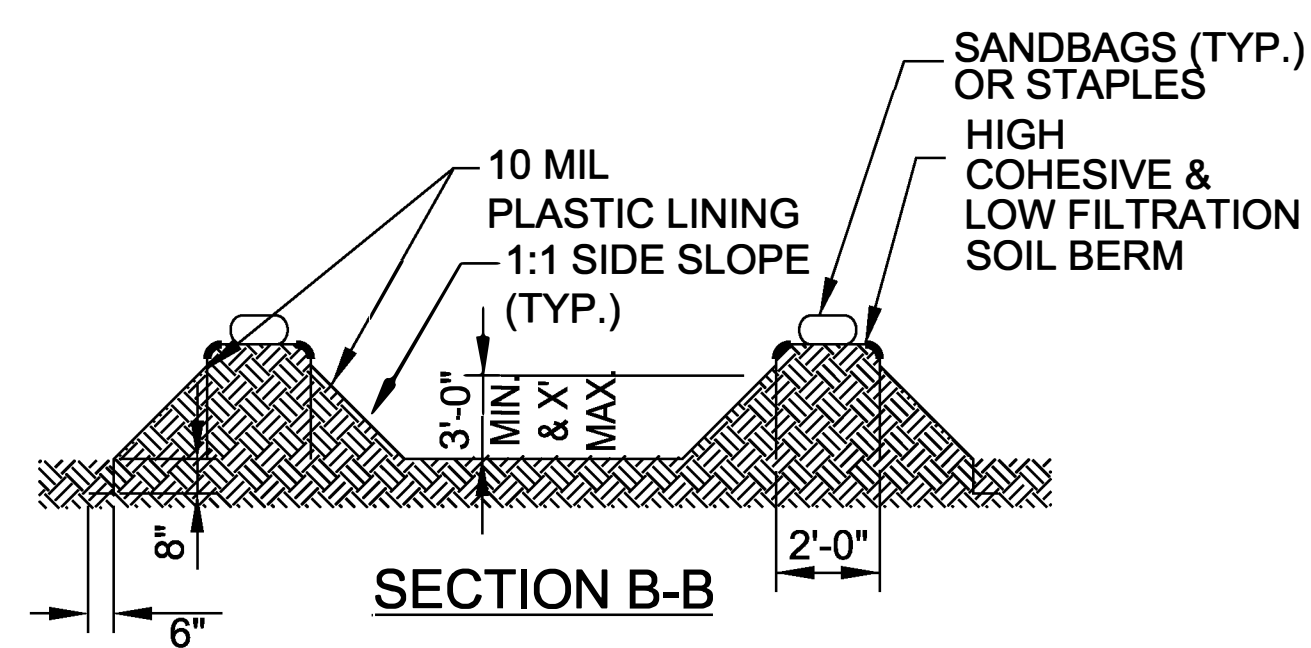
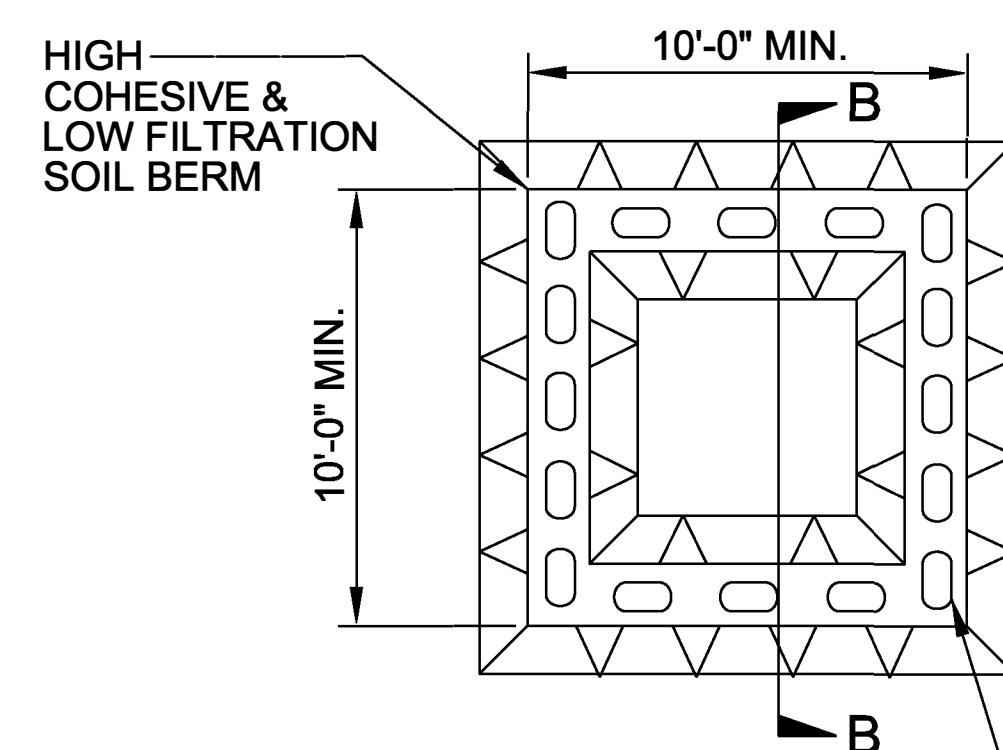

NOTES:

1. ACTUAL LOCATION DETERMINED IN FIELD
2. THE CONCRETE WASHOUT STRUCTURES SHALL BE MAINTAINED WHEN THE LIQUID AND/OR SOLID REACHES 75% OF THE STRUCTURES CAPACITY TO PROVIDE ADEQUATE HOLDING CAPACITY WITH A MINIMUM 12 INCHES OF FREEBOARD.
3. CONCRETE WASHOUT STRUCTURE NEEDS TO BE CLEARLY MARKED WITH SIGNAGE NOTING DEVICE.

PLAN

ABOVE GRADE WASHOUT STRUCTURE

NOT TO SCALE