

p:\gfn\pwbentley.com\gfn\pwbentley.com\Projects\63639\Task 010 B-4626\Discipline\Struct\DN\Rowan 3\Archives\Delete\401_207_B4626_SMU_AS01_790003_102 9/13/2021 2:09:13 PM pdf_color_gfclt_FS.plt Rowan.pen.tbl

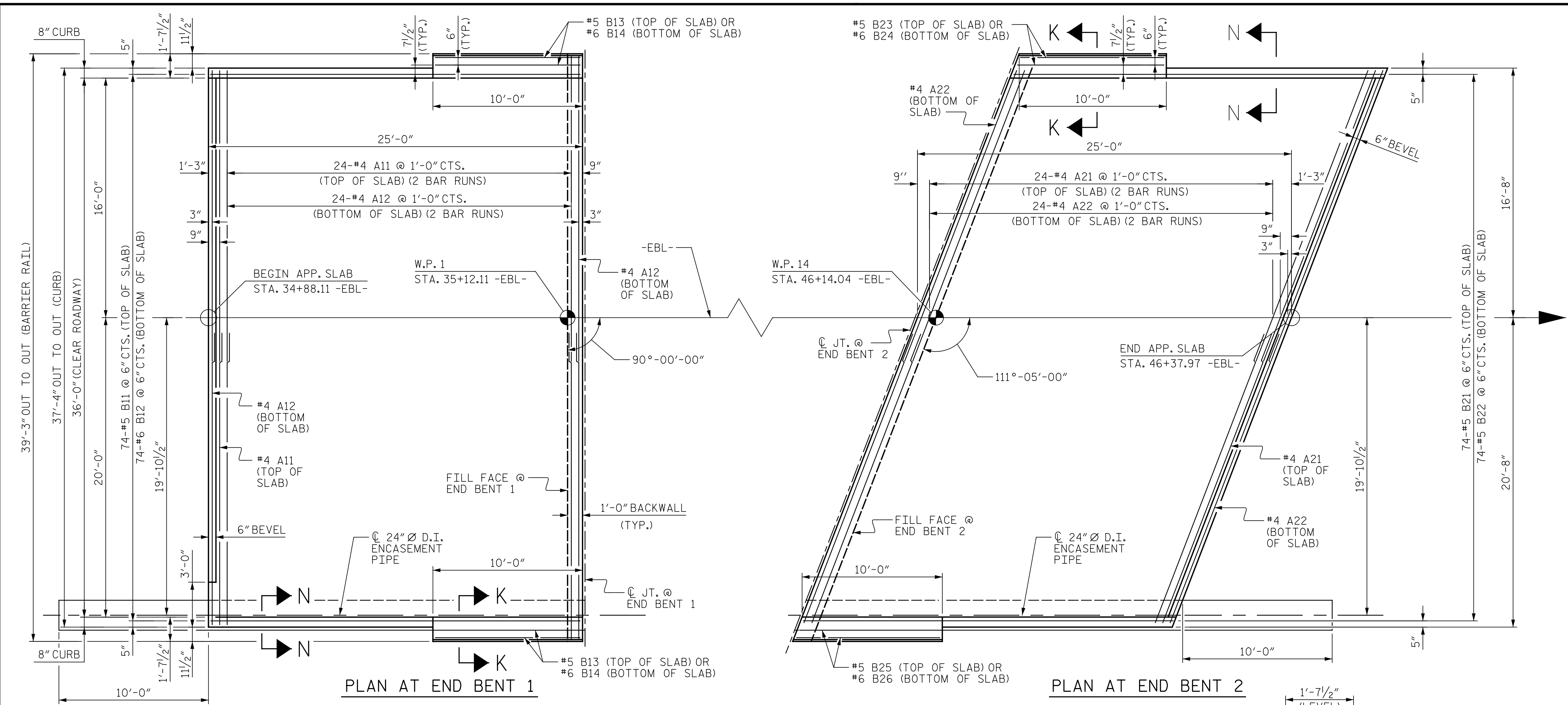

BILL OF MATERIAL					
APPROACH SLAB AT END BENT 1					
BAR	NO.	SIZE	TYPE	LENGTH	WEIGHT
* A11	50	#4	STR.	20'-5"	682
A12	52	#4	STR.	20'-3"	703
* B11	74	#5	STR.	24'-0"	1,852
B12	74	#6	STR.	24'-7"	2,732
* B13	4	#5	STR.	9'-7"	40
B14	4	#6	STR.	9'-7"	58
REINFORCING STEEL **				LBS.	2,608
* EPOXY COATED REINFORCING STEEL **				LBS.	3,459
CLASS AA CONCRETE **				C. Y.	41.3
APPROACH SLAB AT END BENT 2					
BAR	NO.	SIZE	TYPE	LENGTH	WEIGHT
* A21	50	#4	STR.	21'-10"	729
A22	52	#4	STR.	21'-8"	753
* B21	74	#5	STR.	23'-11"	1,846
B22	74	#6	STR.	24'-7"	2,732
* B23	2	#5	STR.	9'-8"	20
B24	2	#6	STR.	9'-8"	29
* B25	2	#5	STR.	9'-11"	21
B26	2	#6	STR.	9'-11"	30
REINFORCING STEEL **				LBS.	3,554
* EPOXY COATED REINFORCING STEEL **				LBS.	2,616
CLASS AA CONCRETE **				C. Y.	41.2

** QUANTITIES FOR BARRIER RAIL ARE NOT INCLUDED. SEE SHEET 2 OF 2.

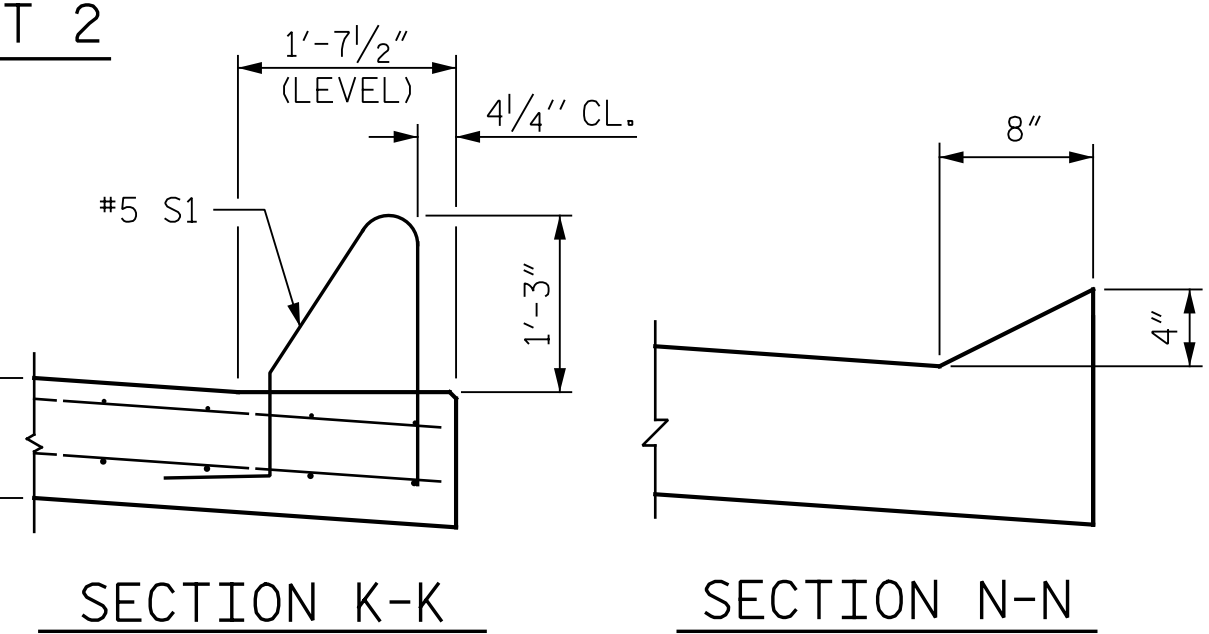
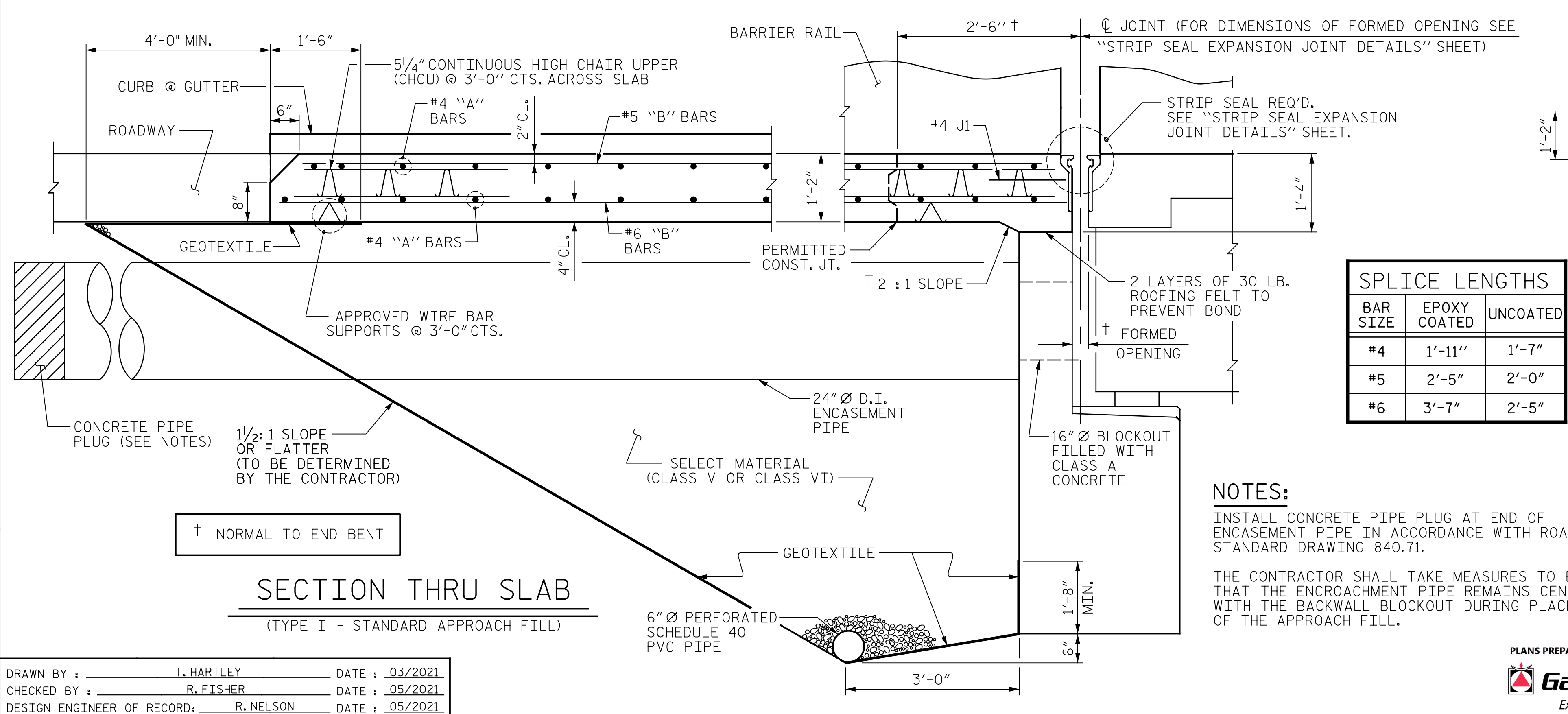

SPLICE LENGTHS		
BAR SIZE	EPOXY COATED	UNCOATED
#4	1'-11"	1'-7"
#5	2'-5"	2'-0"
#6	3'-7"	2'-5"

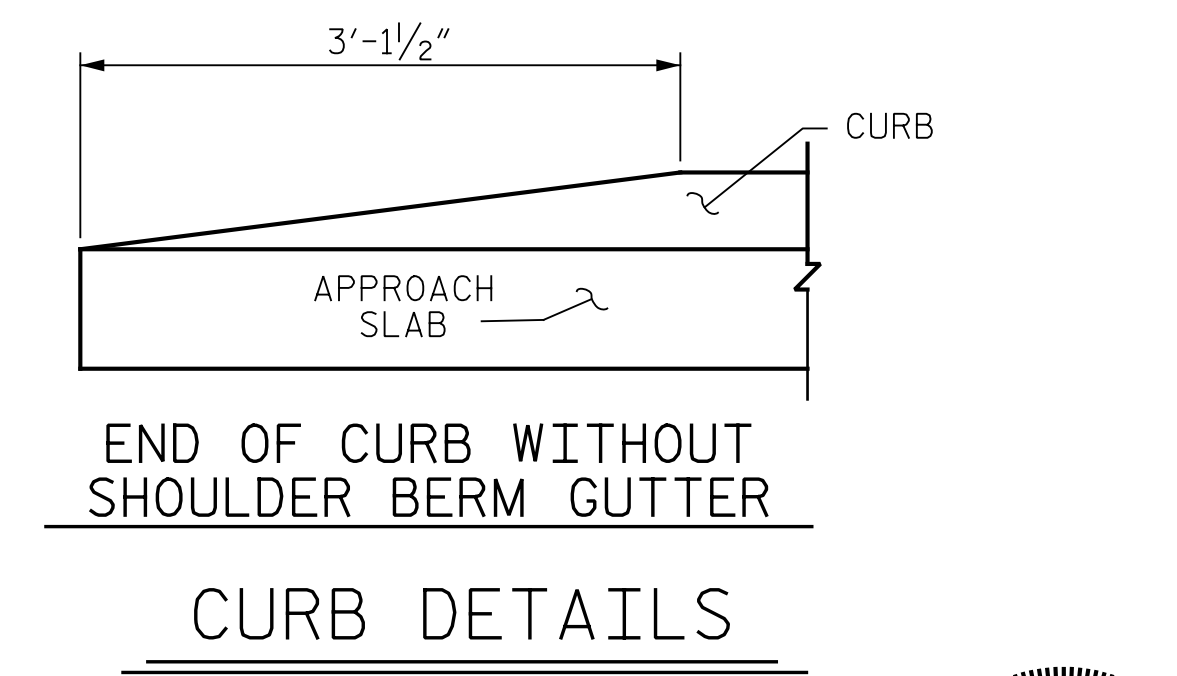

NOTES:
 INSTALL CONCRETE PIPE PLUG AT END OF ENCASMENT PIPE IN ACCORDANCE WITH ROADWAY STANDARD DRAWING 840.71.
 THE CONTRACTOR SHALL TAKE MEASURES TO ENSURE THAT THE ENCROACHMENT PIPE REMAINS CENTERED WITH THE BACKWALL BLOCKOUT DURING PLACEMENT OF THE APPROACH FILL.

PROJECT NO. B-4626
STANLY, ROWAN
AND DAVIDSON COUNTY
 STATION: 45+22.65 -EBL-

SHEET 1 OF 2

STATE OF NORTH CAROLINA
 DEPARTMENT OF TRANSPORTATION
 RALEIGH

BRIDGE APPROACH
 SLAB FOR FLEXIBLE
 PAVEMENT

REVISIONS

NO.	BY:	DATE:	NO.	BY:	DATE:
1			3		
2			4		

SHEET NO. S1-102
 TOTAL SHEETS 125

DRAWN BY: T. HARTLEY DATE: 03/2021
 CHECKED BY: R. FISHER DATE: 05/2021
 DESIGN ENGINEER OF RECORD: R. NELSON DATE: 05/2021

PLANS PREPARED BY:
Gannett Fleming
 Excellence Delivered As Promised

One Glenwood Avenue
 Suite 900
 Raleigh, NC 27603
 (919) 420-7660
 NC Lic. No. F-0270



DOCUMENT NOT CONSIDERED FINAL UNLESS ALL SIGNATURES COMPLETED