

p:\gfn\pw.bentley.com\gfn\pw-01\Documents\Projects\63639\Task 010 B-4626\Discipline\Struct\DN\Rowan 3\Archives\Delete\401\_191\_B4626-SMU\_B10J01\_790003\_094  
 9/2/2021 4:07:40 PM pdf\_color\_gfct\_FS.plt Rowan.pen.tbl

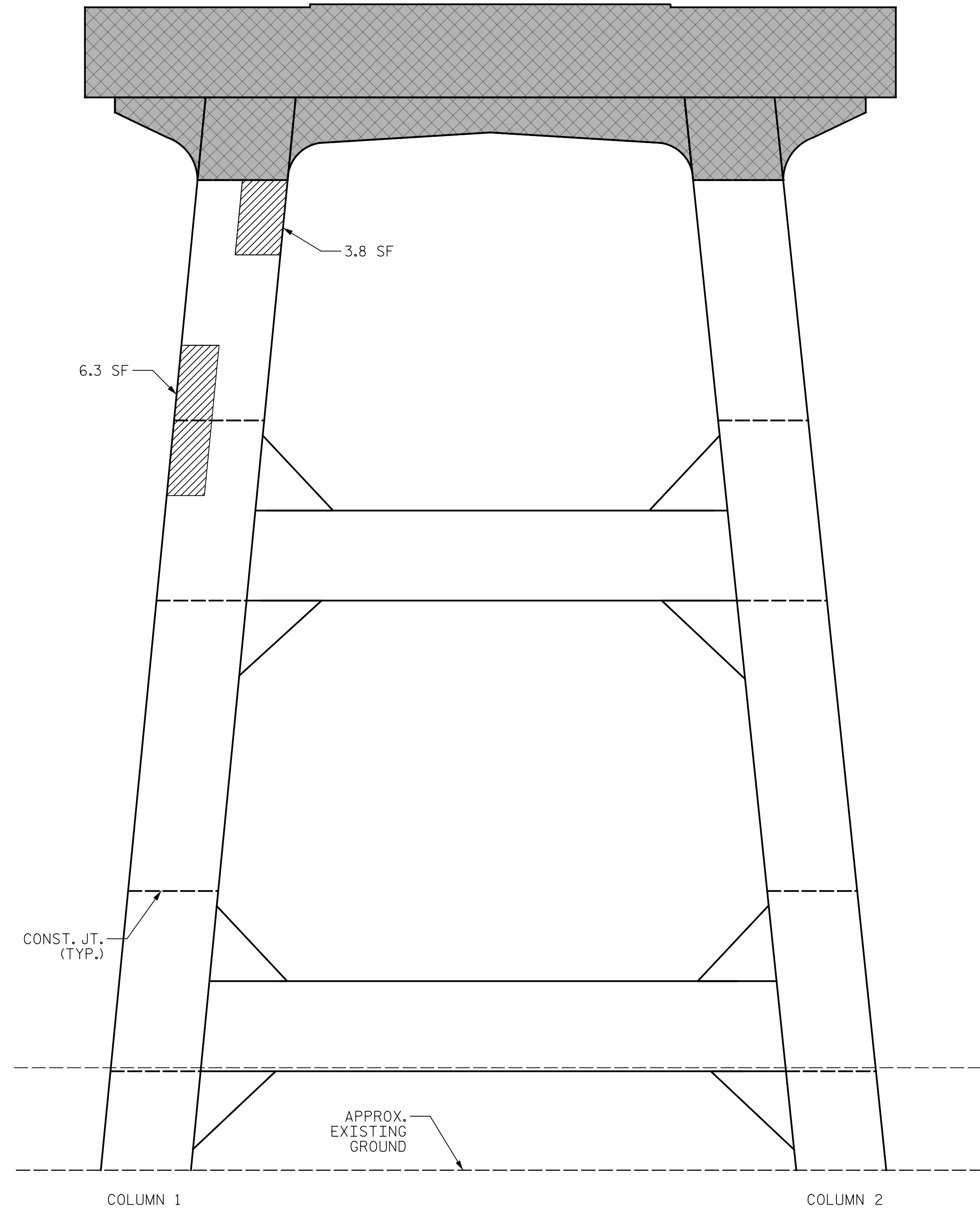

ELEVATION  
(SPAN "J" FACE)

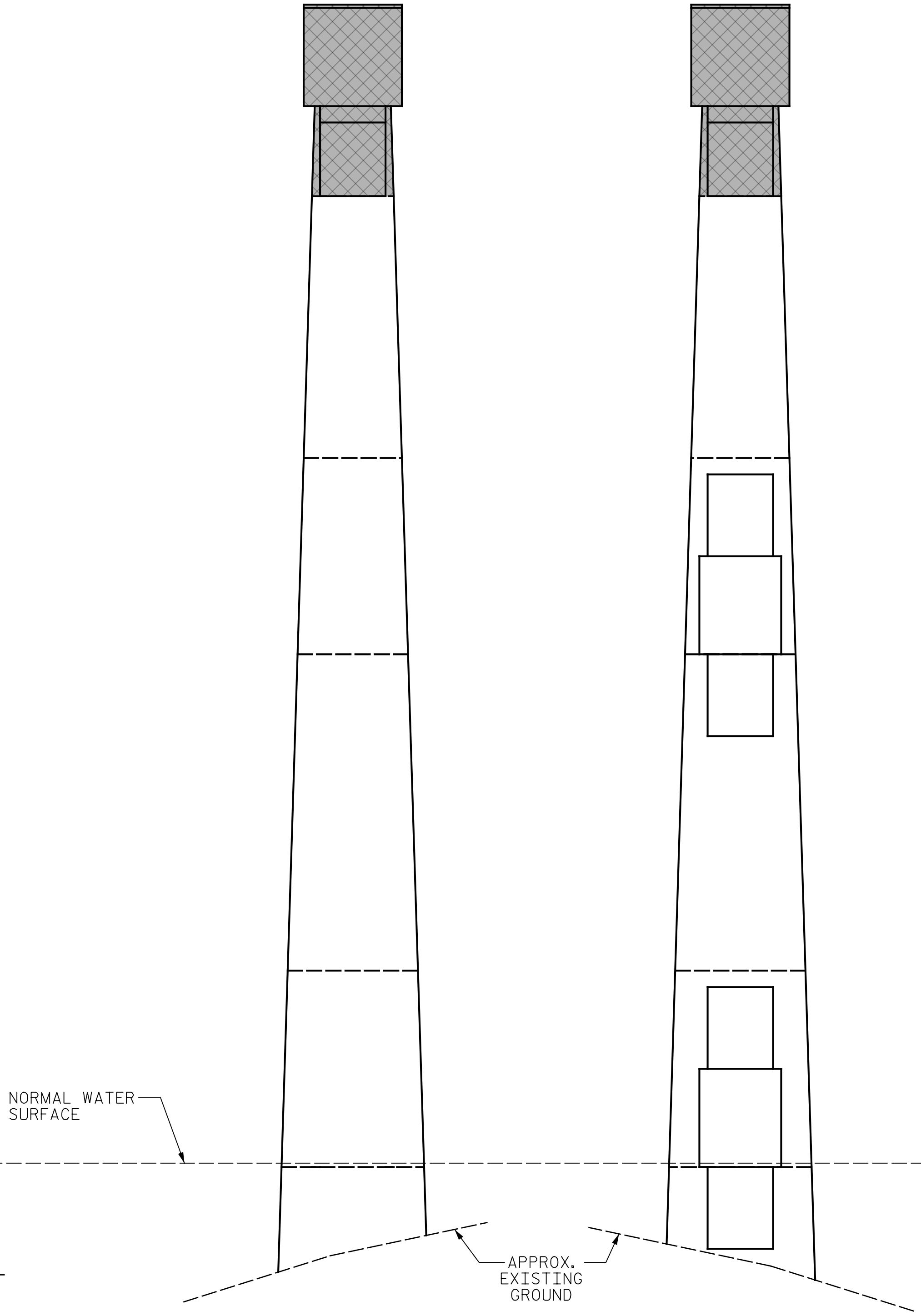

END VIEW  
(RIGHT FACE COL. 2)

INTERIOR VIEW  
(LEFT FACE COL. 2)

AS-BUILT REPAIR QUANTITY TABLE					
BENT 10 REPAIRS	QUANTITIES				
	ESTIMATE		ACTUAL		
SHOTCRETE REPAIRS	AREA SF	VOLUME CF	AREA SF	DEPTH IN.	VOLUME CF
COLUMN & STRUT	26.6	10.7			
EPOXY RESIN INJECTION	LENGTH LF		LENGTH LF		
COLUMN & STRUT	0.0				

VALUES IN CHART REPRESENT ESTIMATED REPAIR TOTALS AFTER REMOVAL OF UNSOUND CONCRETE, MINIMUM OF 1" BEHIND REBAR AND MINIMUM OF 2" CLEARANCE TO SAWCUT. FOR REPAIR DETAILS, SEE "TYPICAL CAP AND COLUMN REPAIR DETAILS" SHEET.

**NOTES:**  
 REPAIR LOCATIONS AND ESTIMATE OF QUANTITIES ARE BASED ON THE BEST INFORMATION AVAILABLE. IF ADDITIONAL REPAIRS NOT SHOWN ON THE DRAWINGS ARE DEEMED NECESSARY BY THE ENGINEER, THE ENGINEER WILL NOTE ON THE DRAWINGS THE APPROXIMATE LOCATION AND DESCRIPTION OF THE REPAIRS AND ENTER THE ACTUAL QUANTITIES INTO THE AS-BUILT REPAIR QUANTITY TABLE.

FOR SHOTCRETE REPAIRS, SEE SPECIAL PROVISIONS.  
 FOR EPOXY RESIN INJECTION, SEE SPECIAL PROVISIONS.  
 WHEN COLUMN REPAIRS ARE INDICATED TO GROUND LINE, EXTEND REPAIR MINIMUM OF 1' BELOW GROUND LINE.  
 FOR PROPOSED BENT CAP REPLACEMENT DETAILS, SEE SUBSTRUCTURE BENT SHEETS.

- SHOTCRETE REPAIR
- ERI - EPOXY RESIN INJECTION
- DEMOLITION (SEE "CAP DEMOLITION DETAILS" SHEET)

PROJECT NO. B-4626  
STANLY, ROWAN  
AND DAVIDSON COUNTY  
 STATION: 45+22.65 -EBL-

SHEET 1 OF 2

STATE OF NORTH CAROLINA  
 DEPARTMENT OF TRANSPORTATION  
 RALEIGH

SUBSTRUCTURE REPAIR  
 BENT 10  
 SPAN "J" FACE



REVISIONS						SHEET NO.
NO.	BY:	DATE:	NO.	BY:	DATE:	S1-94
1			3			TOTAL SHEETS
2			4			125

DRAWN BY : T. HARTLEY/J. MYA DATE : 03/2021  
 CHECKED BY : J. YANACCONI DATE : 05/2021  
 DESIGN ENGINEER OF RECORD: R. NELSON DATE : 05/2021

PLANS PREPARED BY:  
**Gannett Fleming**  
 Excellence Delivered As Promised  
 One Glenwood Avenue  
 Suite 900  
 Raleigh, NC 27603  
 (919) 420-7660  
 NC Lic. No. F-0270

DOCUMENT NOT CONSIDERED FINAL UNLESS ALL SIGNATURES COMPLETED