

p:\gfn\pw\ben\ben\pww\01\Documents\Projects\63639\Task 010 B-4626\Discipline\Struct\DN\Rowan 3\Archives\Delete\401\_099\_B4626\_SMU\_BR04\_790003\_048 9/2/2021 4:02:06 PM pdf\_color\_gfclt\_FS.plt Rowan.pen.tbl

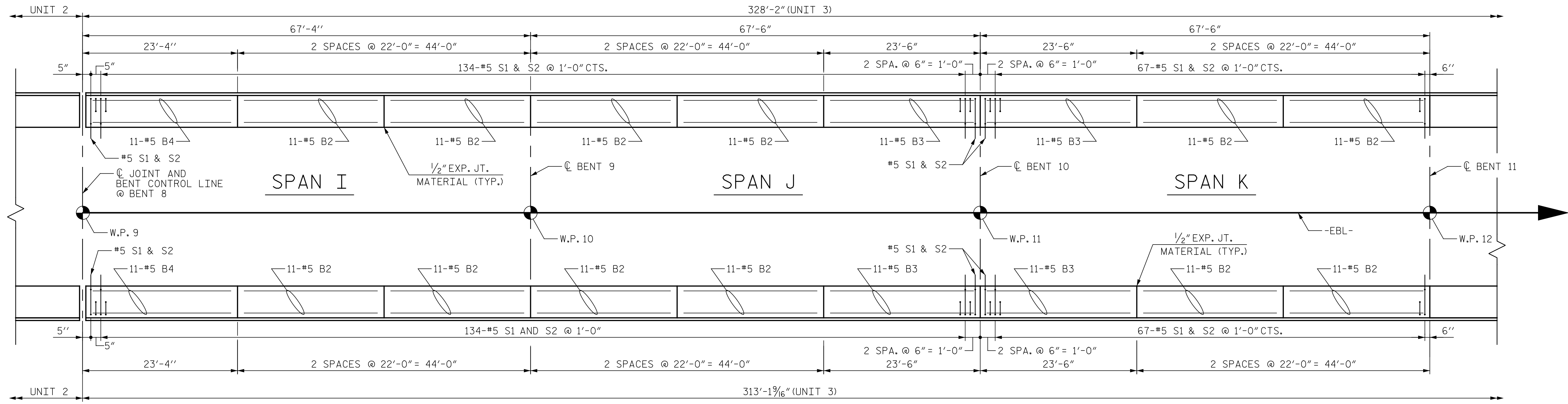

PLAN

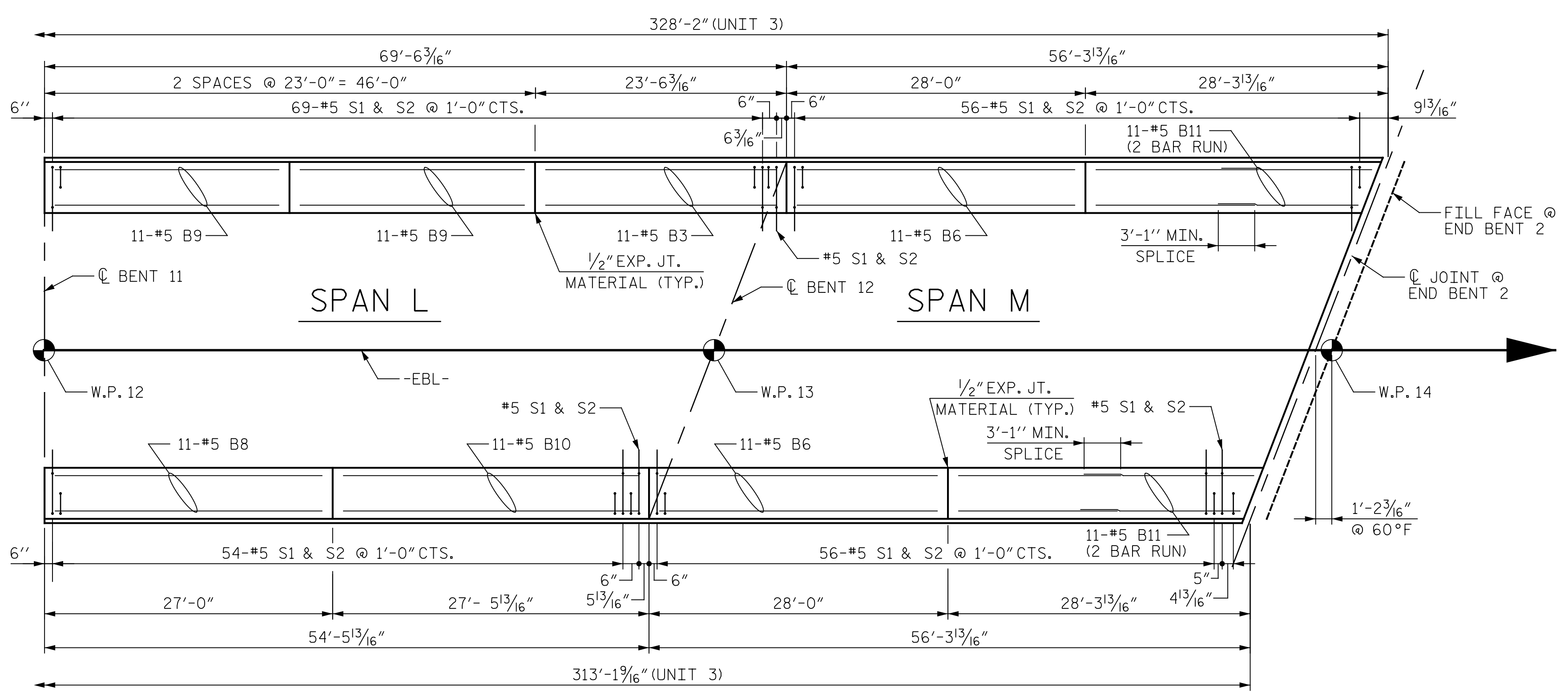

PLAN

PROJECT NO. B-4626  
STANLY, ROWAN  
AND DAVIDSON COUNTY  
 STATION: 45+22.65 -EBL-

SHEET 4 OF 5

STATE OF NORTH CAROLINA  
 DEPARTMENT OF TRANSPORTATION  
 RALEIGH

CONCRETE BARRIER  
 RAIL  
 UNIT 3



DRAWN BY : T. HARTLEY DATE : 04/2021  
 CHECKED BY : R. FISHER DATE : 05/2021  
 DESIGN ENGINEER OF RECORD: R. NELSON DATE : 05/2021

PLANS PREPARED BY:  
**Gannett Fleming**  
 Excellence Delivered As Promised

One Glenwood Avenue  
 Suite 900  
 Raleigh, NC 27603  
 (919) 420-7660  
 NC Lic. No. F-0270

DocuSigned by:  
 Eric B. Nelson  
 9/2/2021

DOCUMENT NOT CONSIDERED  
 FINAL UNLESS ALL  
 SIGNATURES COMPLETED

REVISIONS						SHEET NO. S1-48
NO.	BY:	DATE:	NO.	BY:	DATE:	
1			3			TOTAL SHEETS 125
2			4			