

PLAN @ END BENT 1

PLAN @ END BENT 2

DIMENSIONS SHOWN ARE TYPICAL FOR BOTH APPROACH SLABS

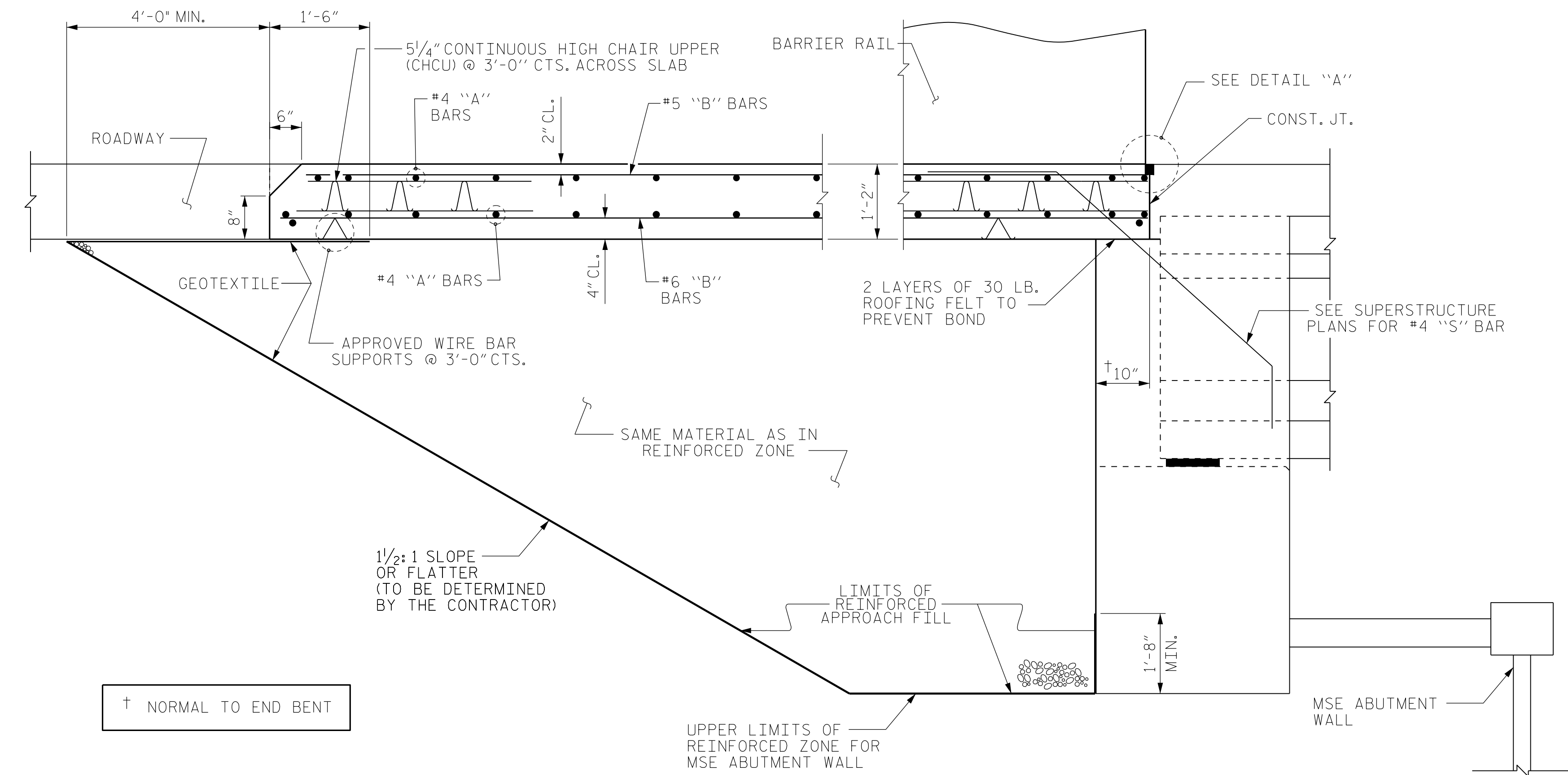

SECTION THRU SLAB

(TYPE III - REINFORCED APPROACH FILL)

DRAWN BY : JAE DATE : 8/21  
 CHECKED BY : ZHB DATE : 8/21  
 DESIGN ENGINEER OF RECORD: MTP DATE : 8/21

\*\*\*\*\*SYSTEM TIME\*\*\*\*\*  
 \*\*\*\*\*DCN\*\*\*\*\*  
 \*\*\*\*\*USERNAME\*\*\*\*\*

NOTES

FOR BRIDGE APPROACH FILL INCLUDING GEOTEXTILE, 6" Ø DRAINAGE PIPE, AND SELECT MATERIAL BACKFILL, SEE ROADWAY PLANS.

GEOTEXTILE SHALL BE TYPE 1 IN ACCORDANCE WITH THE STANDARD SPECIFICATIONS SECTION 1056.

BACKFILL MATERIAL SHALL BE THE SAME MATERIAL USED IN THE THE MSE REINFORCED ZONE.

SELECT MATERIAL BACKFILL IS TO BE CONTINUOUS ALONG FILL FACE OF BACKWALL FROM OUTSIDE EDGE TO OUTSIDE EDGE OF APPROACH SLAB.

APPROACH SLAB SHALL NOT BE CONSTRUCTED PRIOR TO COMPLETION OF THE BRIDGE DECK.

AREA BETWEEN THE WINGWALL AND APPROACH SLAB SHALL BE GRADED TO DRAIN THE WATER AWAY FROM THE FILL FACE OF THE BRIDGE AND SHALL BE PAVED. SEE ROADWAY PLANS.

BILL OF MATERIAL

FOR ONE APPROACH SLAB (2 REQ'D)

BAR	NO.	SIZE	TYPE	LENGTH	WEIGHT
*A1	52	#4	STR	23'-4"	811
A2	54	#4	STR	23'-2"	836
*B1	87	#5	STR	24'-2"	2193
B2	87	#6	STR	24'-8"	3223

REINFORCING STEEL \*\* LBS. 4059

\* EPOXY COATED REINFORCING STEEL \*\* LBS. 3004

CLASS AA CONCRETE \*\* C.Y. 47.1

ALL BAR DIMENSIONS ARE OUT TO OUT

\*\* QUANTITIES FOR BARRIER RAIL ARE NOT INCLUDED. SEE SHEET 2 OF 2.

SPLICE LENGTHS

BAR SIZE	EPOXY COATED	UNCOATED
#4	1'-11"	1'-7"
#5	2'-5"	2'-0"
#6	3'-7"	2'-5"

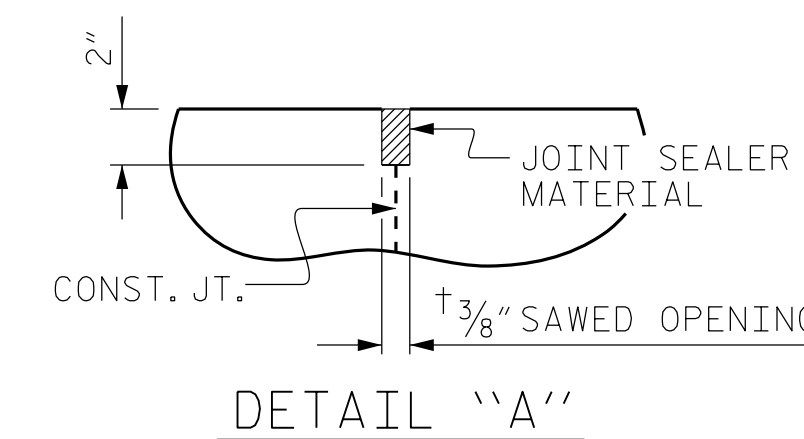

DETAIL "A"

PROJECT NO. R-5737

DAVIDSON COUNTY

STATION: 61+02.86 -L-

SHEET 1 OF 2

**Dewberry**  
 2610 WYCLIFF ROAD  
 SUITE 410  
 RALEIGH, NC 27607  
 PHONE: 919.881.9939  
 NC COA No. F-0929

NORTH CAROLINA PROFESSIONAL ENGINEER  
 SEAL 030046  
 ENGINEER MATTHEW PAYNE  
 9/14/2021

STATE OF NORTH CAROLINA  
 DEPARTMENT OF TRANSPORTATION  
 RALEIGH  
 STANDARD  
 BRIDGE APPROACH SLAB  
 FOR INTEGRAL ABUTMENT

DOCUMENT NOT CONSIDERED FINAL UNLESS ALL SIGNATURES COMPLETED

REVISIONS						SHEET NO.
NO.	BY:	DATE:	NO.	BY:	DATE:	S1-24
1			3			TOTAL SHEETS
2			4			25