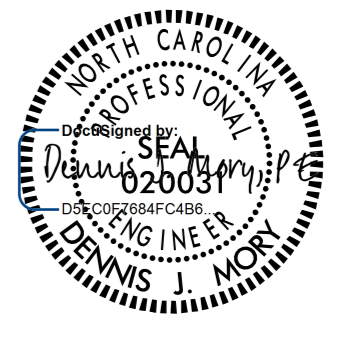
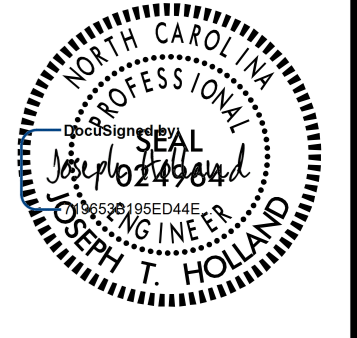

6/2/2019

**PAVEMENT SCHEDULE**

ITEM	DESCRIPTION	ITEM	DESCRIPTION	ITEM	DESCRIPTION	ITEM	DESCRIPTION	ITEM	DESCRIPTION	ITEM	DESCRIPTION	ITEM	DESCRIPTION
(A1)	7" CONCRETE	(C4)	1.5" S9.5C	(D3)	VAR DEPTH I19.0C	(J3)	VAR. DEPTH ABC	(N2)	GEOTEXTILE FOR PAVEMENT STAB.	(R4)	CONC. EXWY GUTTER	(U)	EXIST. PAVEMENT
(A2)	7" CONCRETE wRS	(C5)	3" S9.5C	(E1)	5" B25.0C	(K1)	CHEMICAL STABILIZATION: 7" SOIL-CEMENT BASE OR 8" LIME-TREATED SOIL	(P)	PRIME COAT	(R5)	5" CONC. ISLAND	(V1)	INCIDENTAL MILLING
(C1)	1.5" S9.5B	(C6)	VAR DEPTH S9.5C	(E2)	VAR DEPTH B25.0C	(K2)	8" CLASS IV SUBGRADE STABILIZATION	(R1)	2'-6" C&G	(S)	4" CONC. SIDEWALK	(V2)	INCIDENTAL MILLING
(C2)	3" S9.5B	(D1)	2.5" I19.0C	(J1)	6" ABC	(K2)	8" CLASS IV SUBGRADE STABILIZATION	(R2)	2' MOD. VALLEY CURB	(T)	EARTH MATERIAL	(V3)	1.5" MILLING
(C3)	VAR DEPTH S9.5B	(D2)	4" I19.0C	(J2)	8" ABC	(N1)	GEOTEXTILE FOR SOIL STABILIZATION	(R3)	CONC. SBG	(T1)	AGGR. SHLD. BORROW	(W1)	(W2) WEDGING DETAILS

- NOTES:
1. ALL PAVEMENT EDGE SLOPES ARE 1:1 UNLESS OTHERWISE NOTED.
  2. SEE PLANS FOR LOCATION OF ACCELERATION AND DECELERATION LANES.
  3. SEE PLANS FOR LOCATION OF TURN LANE AND INTERSECTION TURNOUTS.
  4. SEE PLANS FOR LOCATION OF ALL PAVEMENT TAPERS.
  5. ALL DRIVEWAY RADII IS 10' UNLESS SHOWN OTHERWISE ON PLANS.
  6. ALL SIDEWALK CORNER RADII IS 3' UNLESS SHOWN OTHERWISE ON PLANS.
  7. THE WELDED WIRE MESH FOR THE ROUNDABOUT TRUCK APRONS SHALL BE (4x4 W3.5xW3.5) OR (6x6 W5xW5).
  8. THE ROUNDABOUT TRUCK APRONS SHALL HAVE 15' JOINT SPACING ON TOP OF VARIABLE DEPTH ABC.
  9. SEE SHEETS 2B-1 THRU 2B-6 FOR CONCRETE ISLAND & TRUCK APRON DETAILS.

PROJECT REFERENCE NO. R-5737	SHEET NO. 2A-3
ROADWAY DESIGN ENGINEER 	PAVEMENT DESIGN ENGINEER 
8/24/2021	8/24/2021

**DOCUMENT NOT CONSIDERED FINAL UNLESS ALL SIGNATURES COMPLETED**

**Dewberry**

2610 WYCLIFF ROAD  
RALEIGH, NC 27607  
PHONE: 919.881.9939  
NC CCA No. F-0928

NC DEPARTMENT OF TRANSPORTATION  
PAVEMENT MANAGEMENT UNIT  
1593 MAIL SERVICE CENTER  
RALEIGH, NC 27699-1593

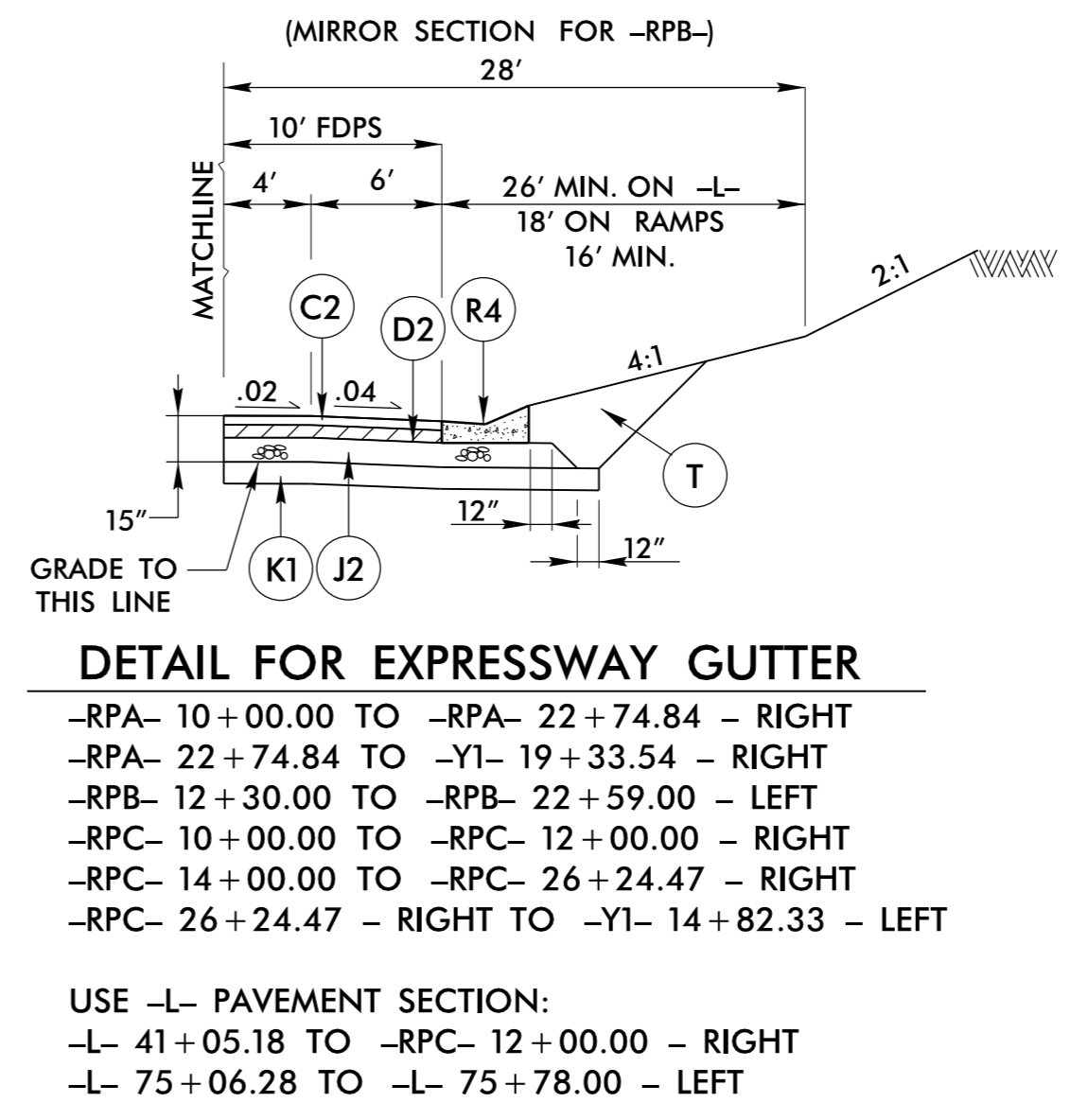
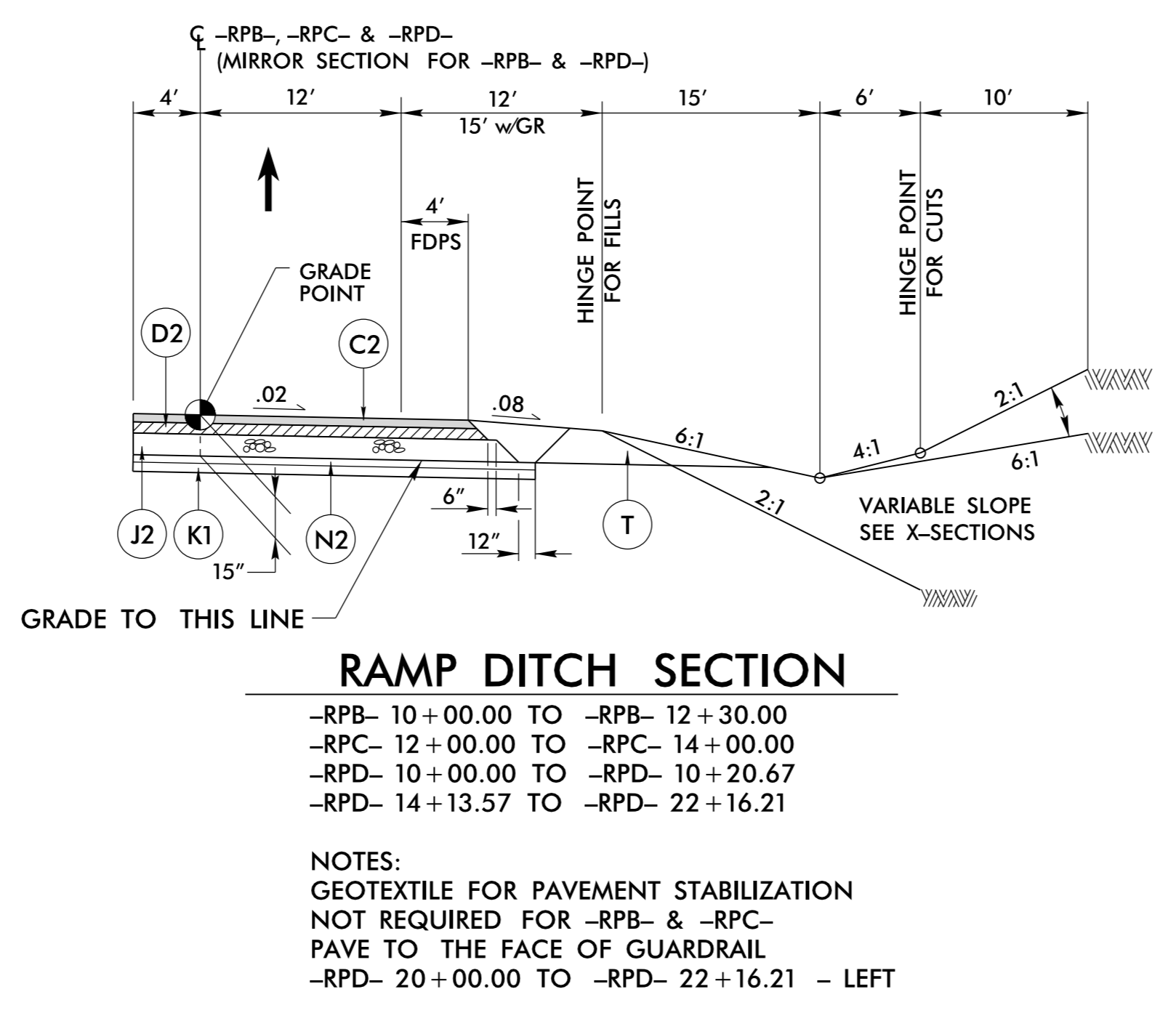
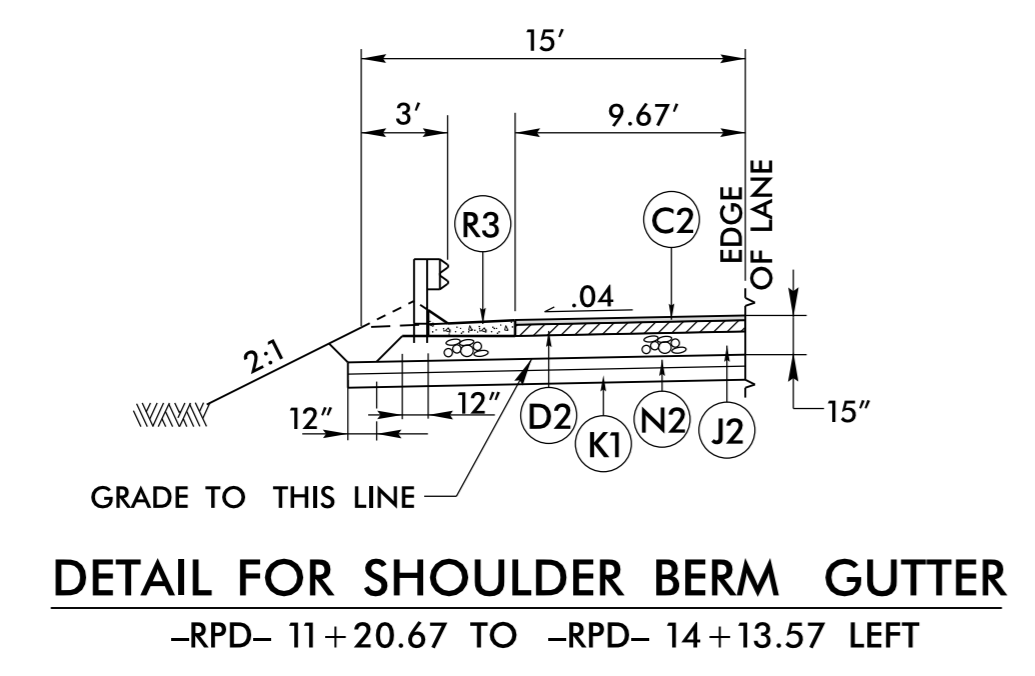
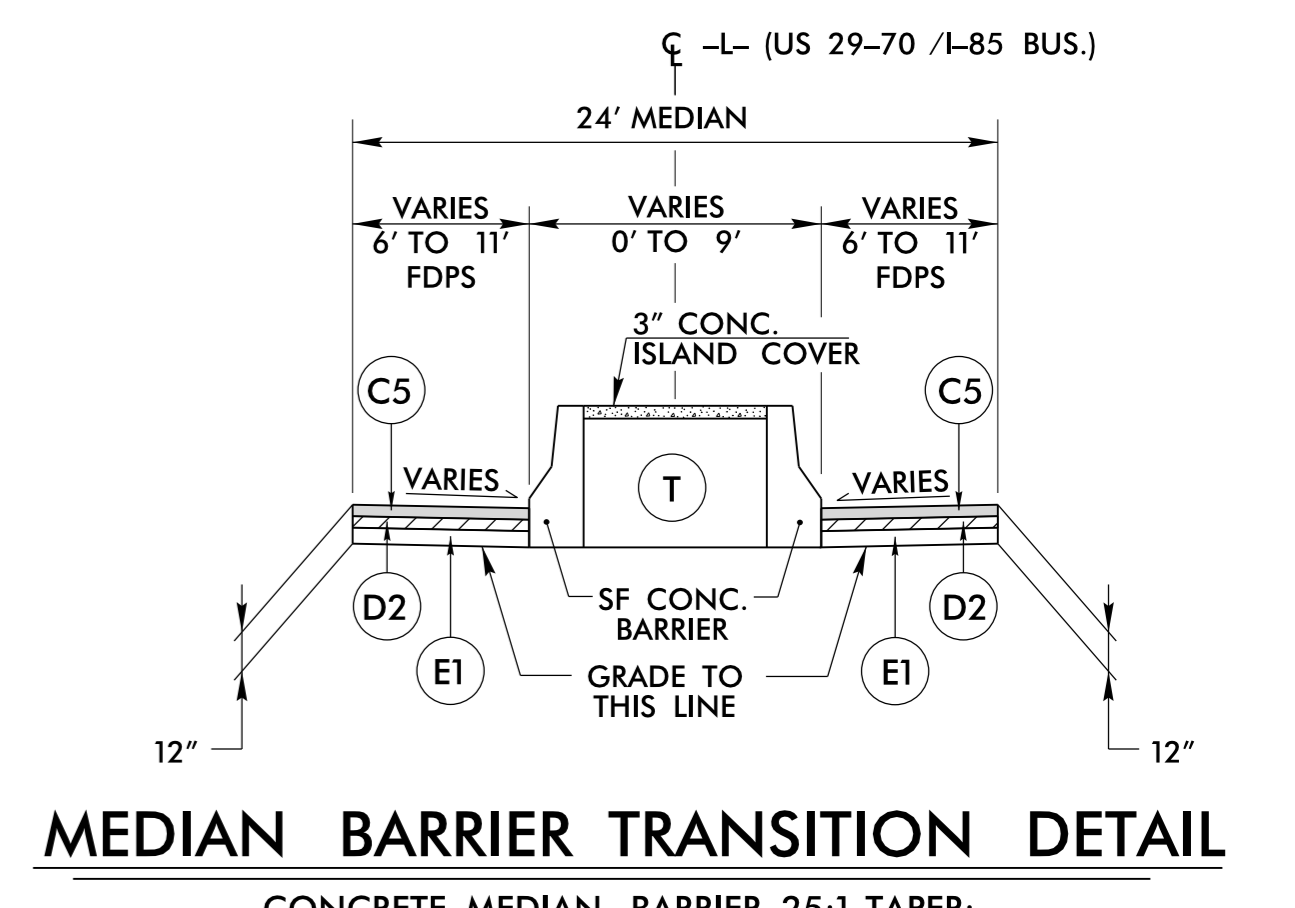
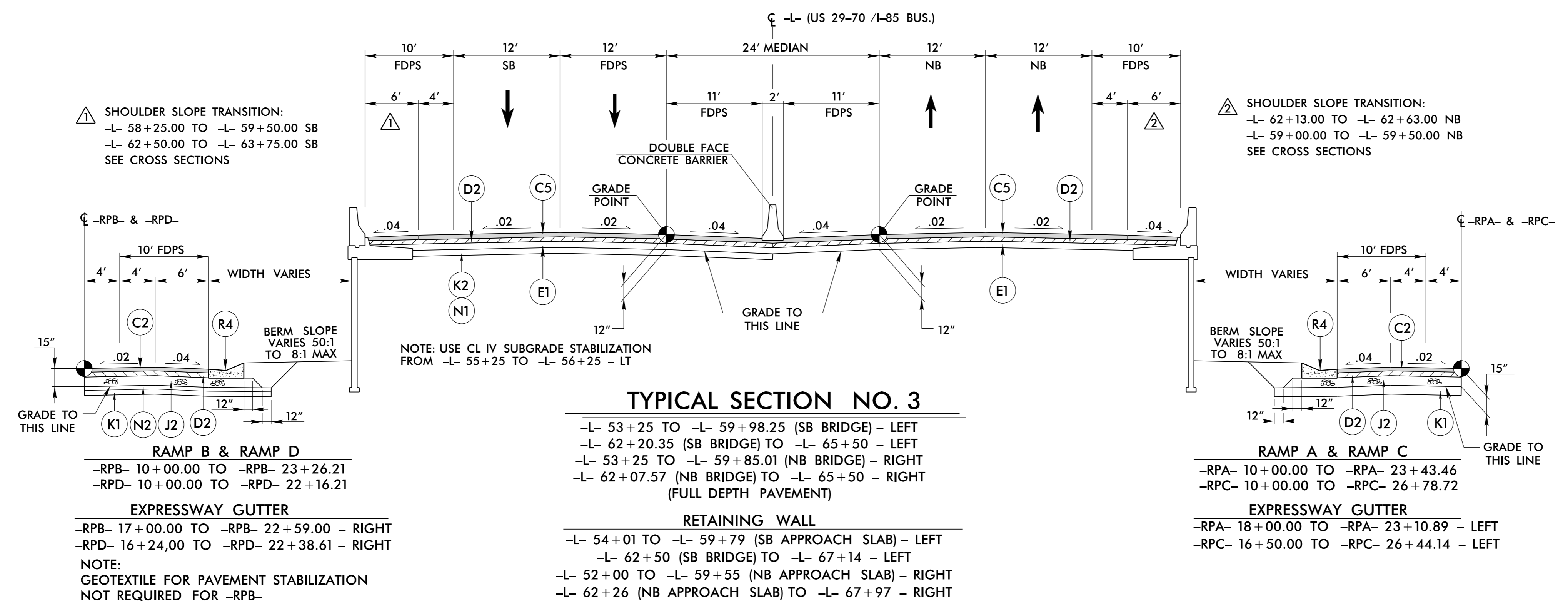

8/24/2021 10:40:03 AM  
IT:SEFC:\PROJECTS\17-RD1-11P-02A-3.dgn