

**CLEARING AND GRUBBING
EROSION CONTROL FOR
CONSTRUCTION SHEET 07**

PI Sta	PI Sta	PI Sta	PI Sta	PI Sta
52+50.59	55+48.13	60+12.41	63+20.66	74+83.10
$\Delta = 51^{\circ}50'58.6"$ (RT)	$\Delta = 24^{\circ}28'32.5"$ (RT)	$\Delta = 38^{\circ}39'22.3"$ (RT)	$\Delta = 8^{\circ}14'30.6"$ (LT)	$\Delta = 127^{\circ}49'20.5"$ (LT)
D = 16'51"06.1"	D = 8'00"39.4"	D = 17'00"00.0"	D = 6'30"00.0"	D = 1'48"48.8"
L = 307.68'	L = 305.53'	L = 227.39'	L = 126.80'	L = 1082.00'
T = 165.28'	T = 155.13'	T = 118.21'	T = 63.51'	T = 990.50'
R = 340.00'	R = 715.22'	R = 337.03'	R = 881.47'	R = 485.00'
SE = 6%	SE = 6%	SE = 6%	SE = 5%	SE = 6%
RO = 126'	RO = 126'	RO = 126'	RO = 105'	RO = 126'
* V = 35 MPH	V = 45 MPH	* V = 30 MPH	V = 50 MPH	V = 40 MPH

**ROCK PLATING -L- STA. 56+30 TO 56+75 LT

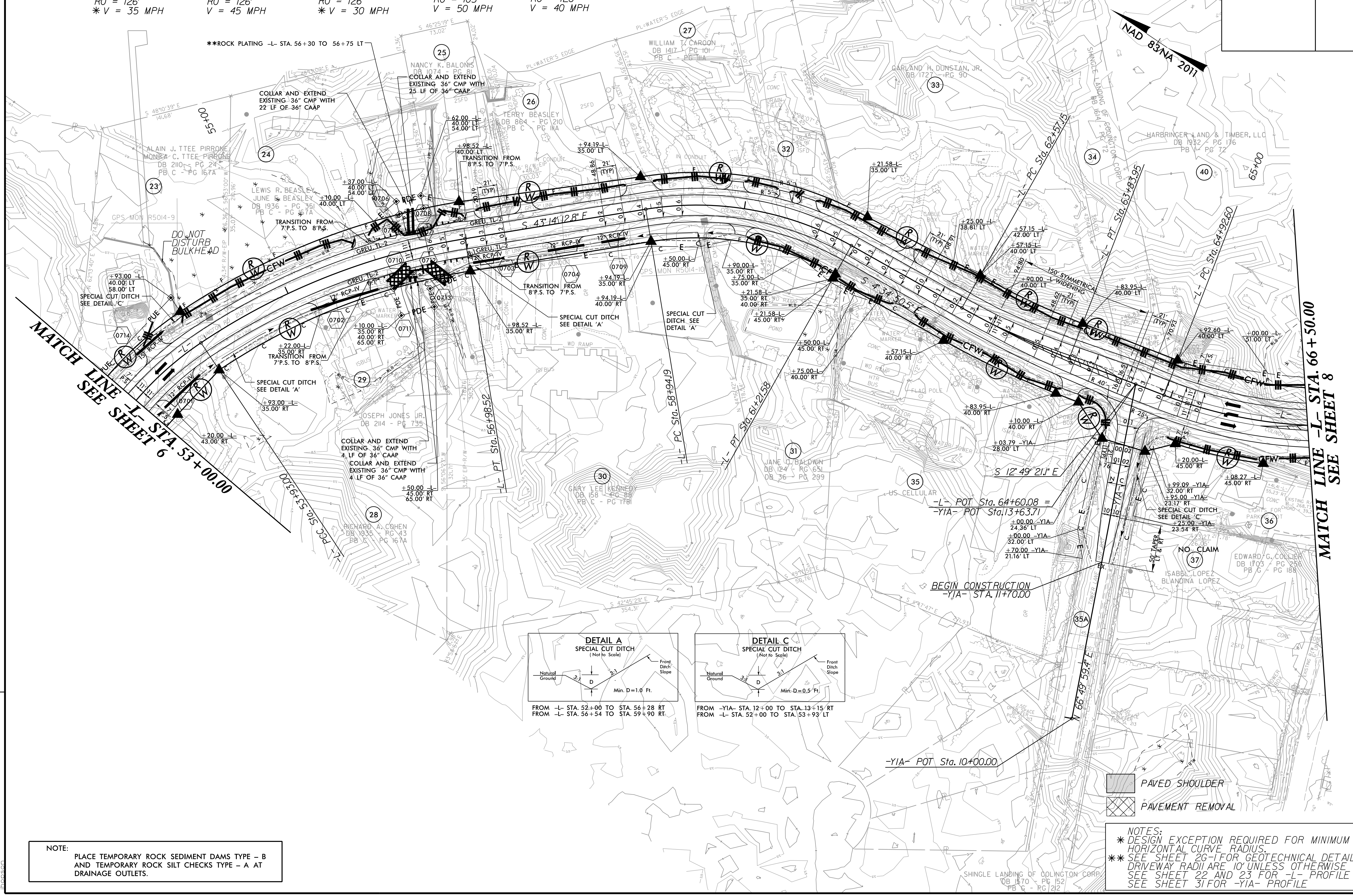

MATCH LINE -L- STA. 53+00.00
SEE SHEET 6

MATCH LINE -L- STA. 66+50.00
SEE SHEET 8

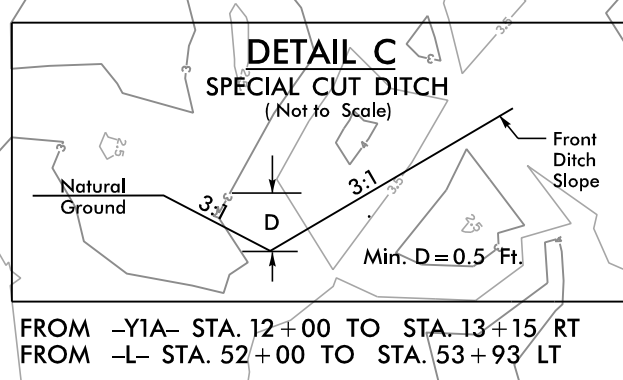
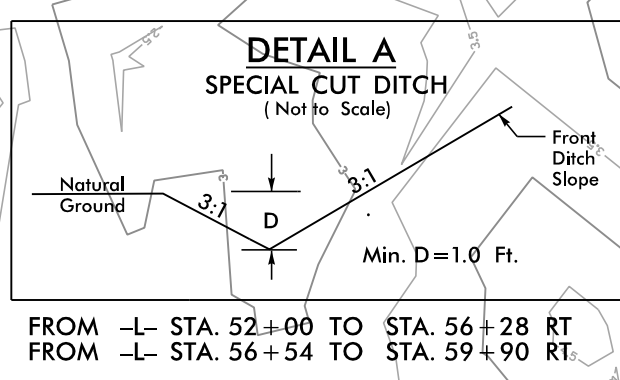

NOTE:
PLACE TEMPORARY ROCK SEDIMENT DAMS TYPE - B AND TEMPORARY ROCK SILT CHECKS TYPE - A AT DRAINAGE OUTLETS.

NOTES:
* DESIGN EXCEPTION REQUIRED FOR MINIMUM HORIZONTAL CURVE RADIUS.
** SEE SHEET 26-1 FOR GEOTECHNICAL DETAILS. DRIVEWAY RADII ARE 10' UNLESS OTHERWISE NOTED. SEE SHEET 22 AND 23 FOR -L- PROFILE. SEE SHEET 31 FOR -YIA- PROFILE.

RIGHT OF WAY REVISION - 9/28/2017 - ADJUSTED RIGHT OF WAY AND TEMPORARY CONSTRUCTION EASEMENT ON PARCEL 30 AND 33.

REVISIONS

I:\52016\2016\commental\Design\RE014_hyd_EC_psh_07.dgn 8/17/19