

EDI MODEL 2018ECLip-NC CONFLICT MONITOR
PROGRAMMING DETAIL
(remove jumpers and set switches as shown)

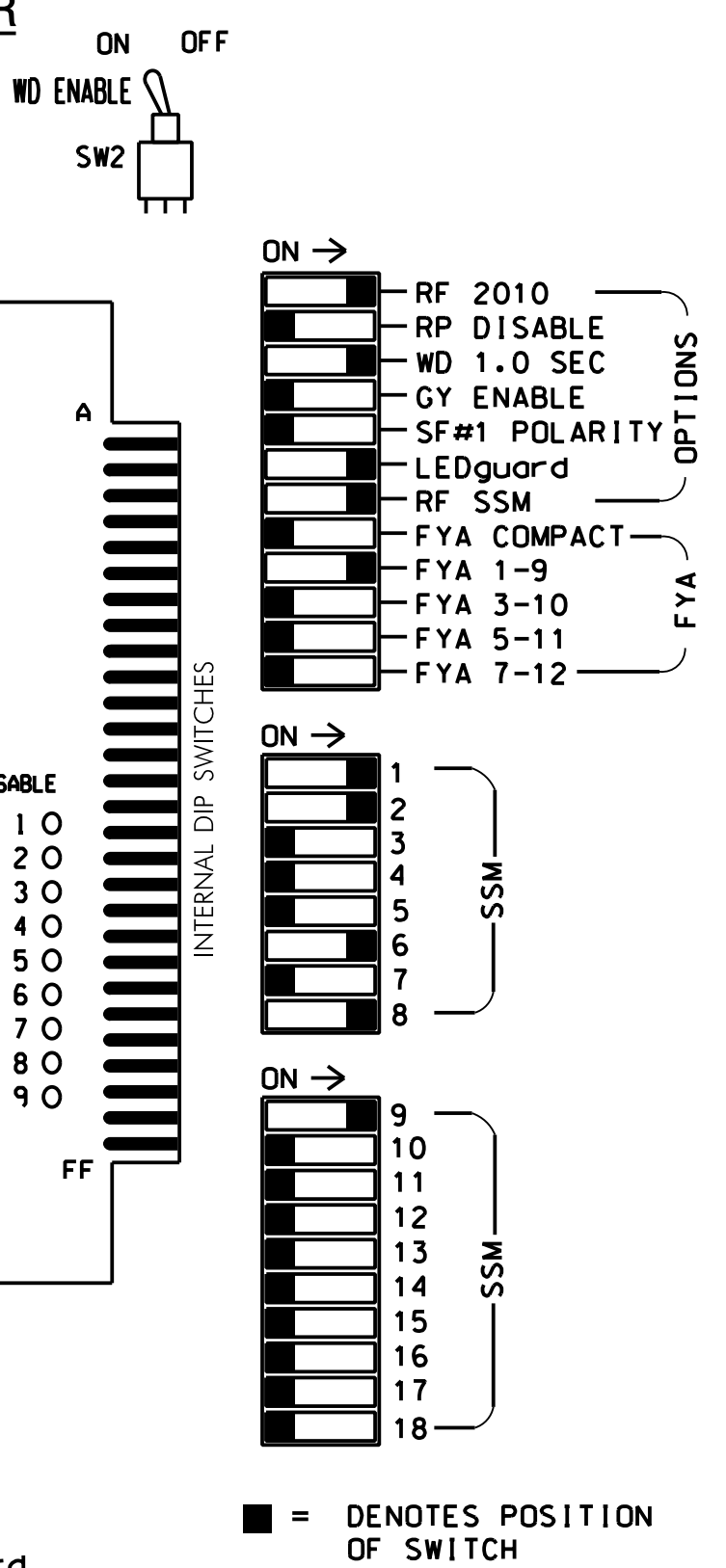
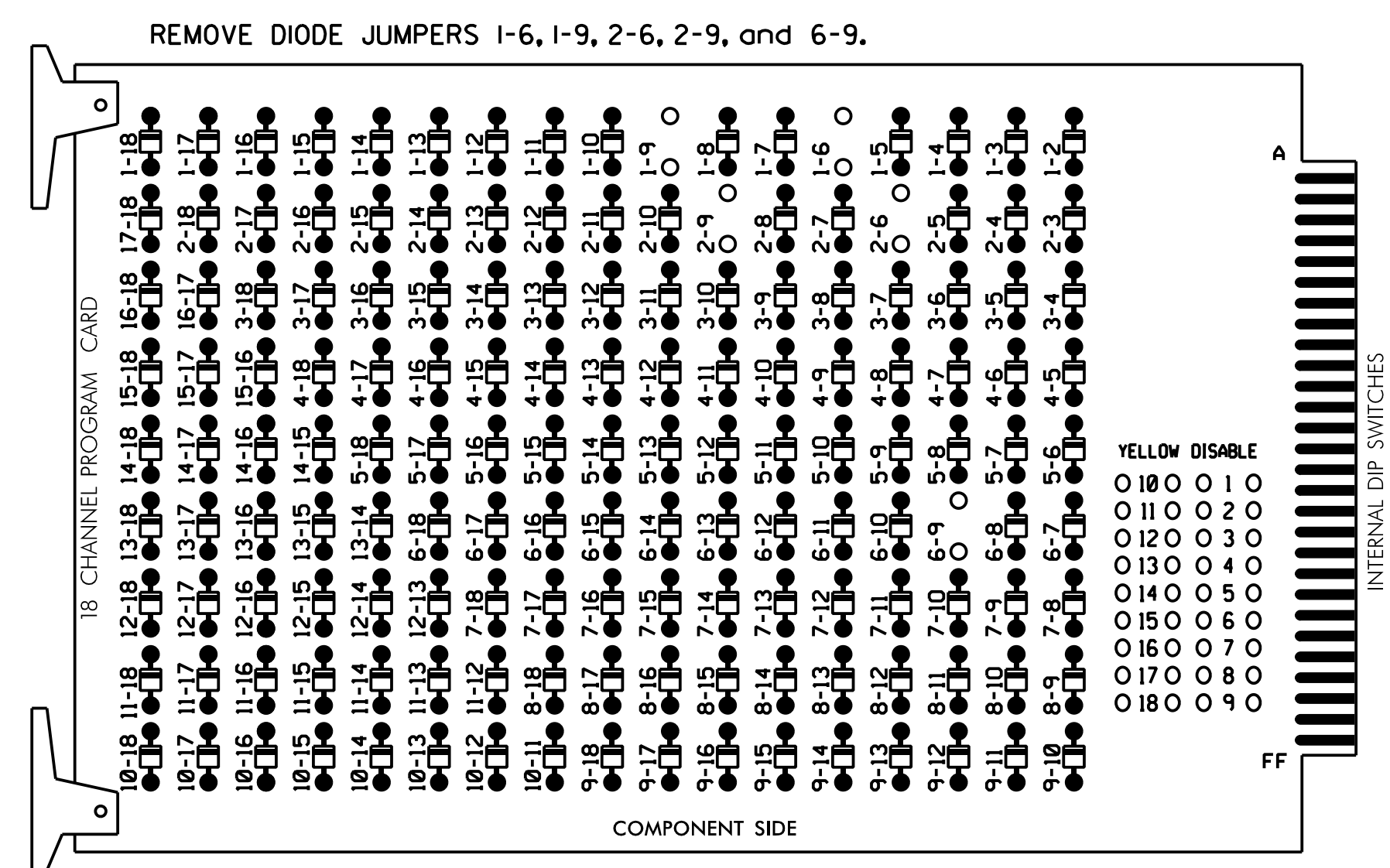

- NOTES:**
- Card is provided with all diode jumpers in place. Removal of any jumper allows its channels to run concurrently.
 - Ensure jumpers SEL2-SEL5 and SEL9 are present on the monitor board.
 - Ensure that Red Enable is active at all times during normal operation.
 - Integrate monitor with Ethernet network in cabinet.

NOTES

- To prevent "flash-conflict" problems, insert red flash program blocks for all unused vehicle load switches in the output file. The installer shall verify that signal heads flash in accordance with the Signal Plans.
- Enable Simultaneous Gap-Out for all Phases.
- Program phases 2 and 6 for Variable Initial and Gap Reduction.
- Program phases 2 and 6 for Startup In Green.
- Program phases 2 and 6 for Yellow Flash, and overlap 1 as Wag Overlaps.
- The cabinet and controller are part of the Jacksonville Signal System.

EQUIPMENT INFORMATION

CONTROLLER.....2070E
 CABINET.....332 W/AUX
 SOFTWARE.....ECONOLITE OASIS
 CABINET MOUNT.....BASE
 OUTPUT FILE POSITIONS...18 WITH AUX. OUTPUT FILE
 LOAD SWITCHES USED.....S1,S2,S8,S11,AUX S1
 PHASES USED.....1,2,6,8
 OVERLAP "A".....1+2
 OVERLAP "B".....NOT USED
 OVERLAP "C".....NOT USED
 OVERLAP "D".....NOT USED

SIGNAL HEAD HOOK-UP CHART

LOAD SWITCH NO.	S1	S2	S3	S4	S5	S6	S7	S8	S9	S10	S11	S12	AUX S1	AUX S2	AUX S3	AUX S4	AUX S5	AUX S6
CMU CHANNEL NO.	1	2	13	3	4	14	5	6	15	7	8	16	9	10	17	11	12	18
PHASE	1	2	2 PED	3	4	4 PED	5	6	6 PED	7	8	8 PED	OLA	OLB	SPARE	OLC	OLD	SPARE
SIGNAL HEAD NO.	11*	82	21,22	NU	NU	NU	NU	61,62	NU	NU	22	81,82	NU	11*	NU	NU	NU	NU
RED	*	128						134				107						
YELLOW		129						135				108						
GREEN		130						136				109						
RED ARROW																		A121
YELLOW ARROW		126										108						A122
FLASHING YELLOW ARROW																		A123
GREEN ARROW	127	127										109						

NU = Not Used
 * Denotes install load resistor. See load resistor installation detail this sheet.
 ★ See pictorial of head wiring in detail this sheet.

FYA SIGNAL WIRING DETAIL
(wire signal head as shown)

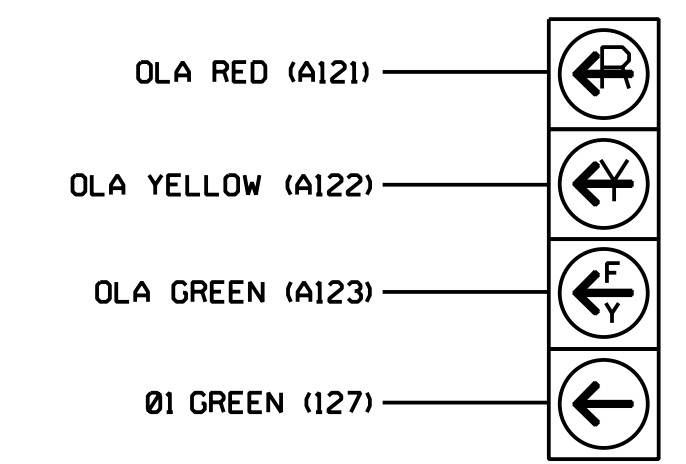

NOTE
 The sequence display for signal head 11 requires special logic programming. See sheet 2 for programming instructions.

INPUT FILE POSITION LAYOUT
(front view)

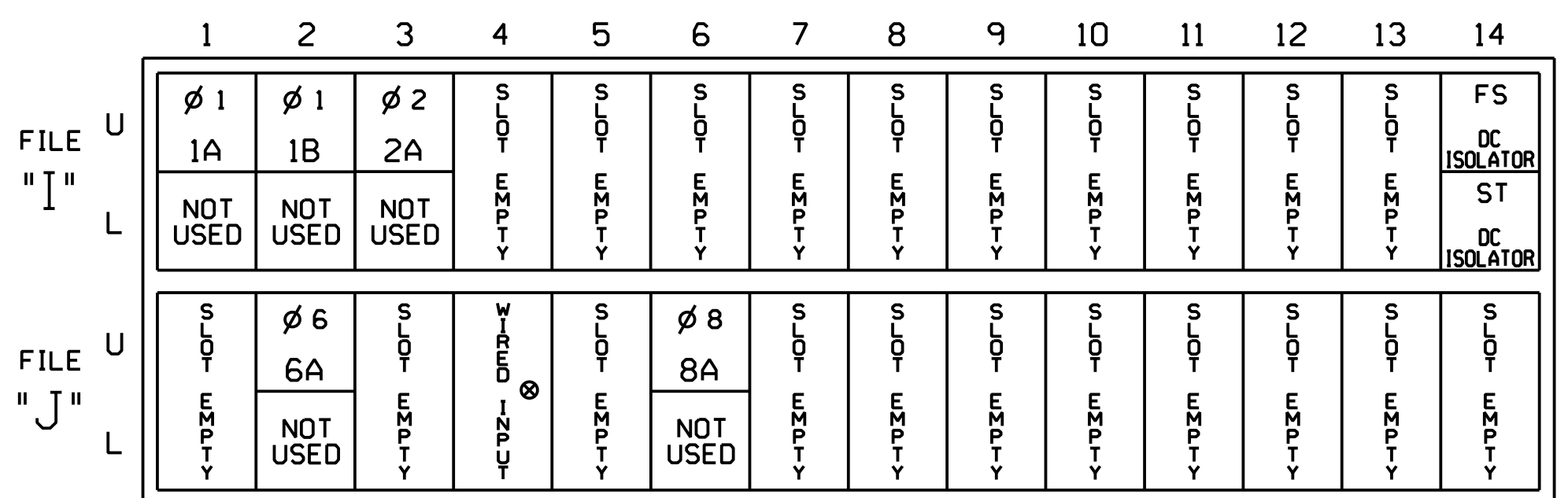

EX.: 1A, 2A, ETC. = LOOP NO.'S
 FS = FLASH SENSE
 ST = STOP TIME

INPUT FILE CONNECTION & PROGRAMMING CHART

LOOP NO.	LOOP TERMINAL	INPUT FILE POS.	PIN NO.	INPUT ASSIGNMENT NO.	DETECTOR NO.	NEMA PHASE	CALL	EXTEND	FULL TIME DELAY	STRETCH TIME	DELAY TIME
1A ¹	TB2-1,2	I1U	56	18	1	1	Y	Y			15
	-	J4U	48	10★	26	6	Y	Y	Y		3
	-	I1U	56	18★	51	1	Y	Y			3
1B	TB2-5,6	I2U	39	1	2	1	Y	Y			15
2A	TB2-9,10	I3U	63	25	32	2	Y	Y			
6A	TB3-5,6	J2U	40	2	6	6	Y	Y			
8A	TB5-9,10	J6U	42	4	8	8	Y	Y			3

¹Add jumper from I1-W to J4-W, on rear of input file.
 ★ See Input Page Assignment programming details on sheet 3.

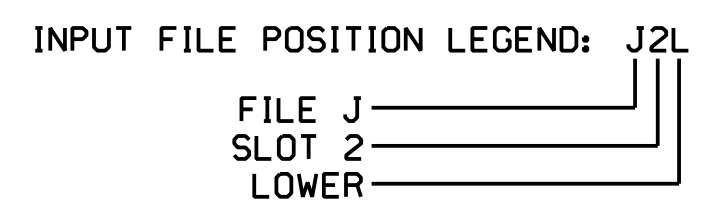

LOAD RESISTOR INSTALLATION DETAIL
(install resistor as shown)

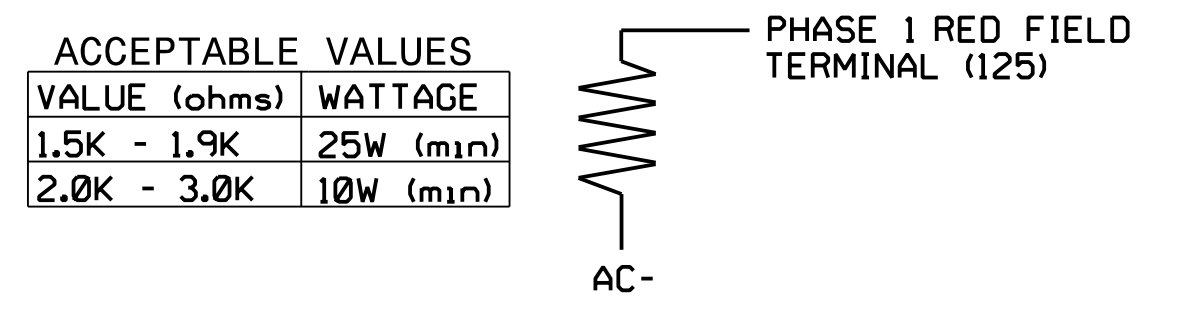

Electrical Detail - Sheet 1 of 4
 Signal Upgrade

DOCUMENT NOT CONSIDERED FINAL UNLESS ALL SIGNATURES COMPLETED

 HNTB NORTH CAROLINA, P.C. 343 E. Six Forks Road, Suite 200 Raleigh, North Carolina 27609 NC License No: C-1554 (919) 546-8997	Prepared for: NORTH CAROLINA DEPARTMENT OF TRANSPORTATION	SR 1308 (Gum Branch Road) at SR 1311 (Cow Horn Road)	SEAL NORTH CAROLINA PROFESSIONAL ENGINEER SEAL 031464 NATASHA R. SIMMONS	
	Division 03 Onslow Co. Jacksonville	PLAN DATE: October 2018 REVIEWED BY: A.D. Klinksiek	PREPARED BY: A.H. Thornburg REVIEWED BY: N.R. Simmons	DocuSigned by: Natasha R. Simmons 6/30/2021
	REVISIONS: _____ INITI: _____ DATE: _____	SIGNATURE: _____ DATE: _____	_____	_____
	_____	_____	_____	_____