

STATE OF NORTH CAROLINA  
DEPT. OF TRANSPORTATION  
DIVISION OF HIGHWAYS  
RALEIGH, N.C.

2-19

ENGLISH DETAIL DRAWING FOR  
**TYPE 'A' SIGNS**  
WELDED STUD CONSTRUCTION

SHEET 1 OF 2

**901D10**

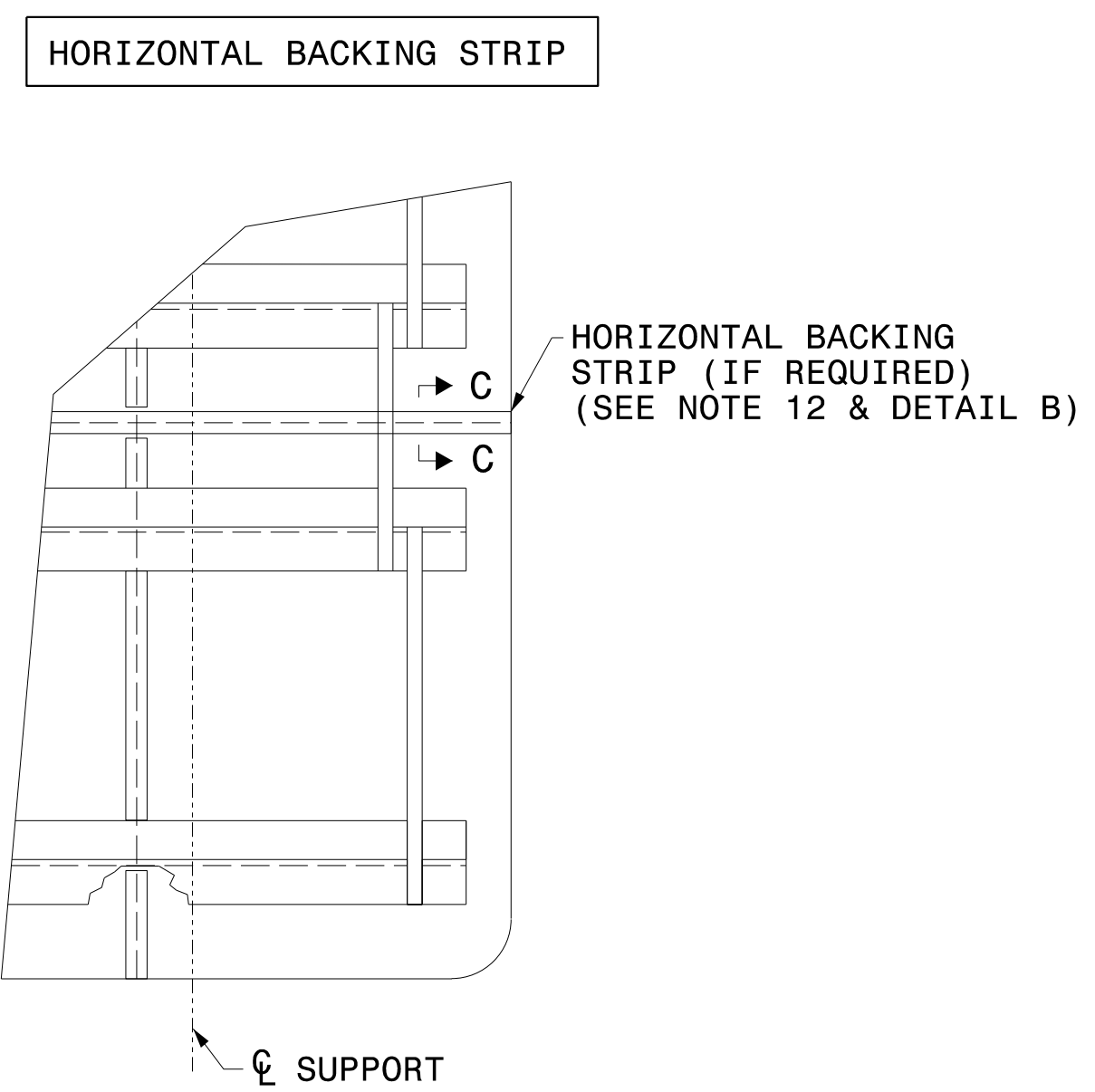
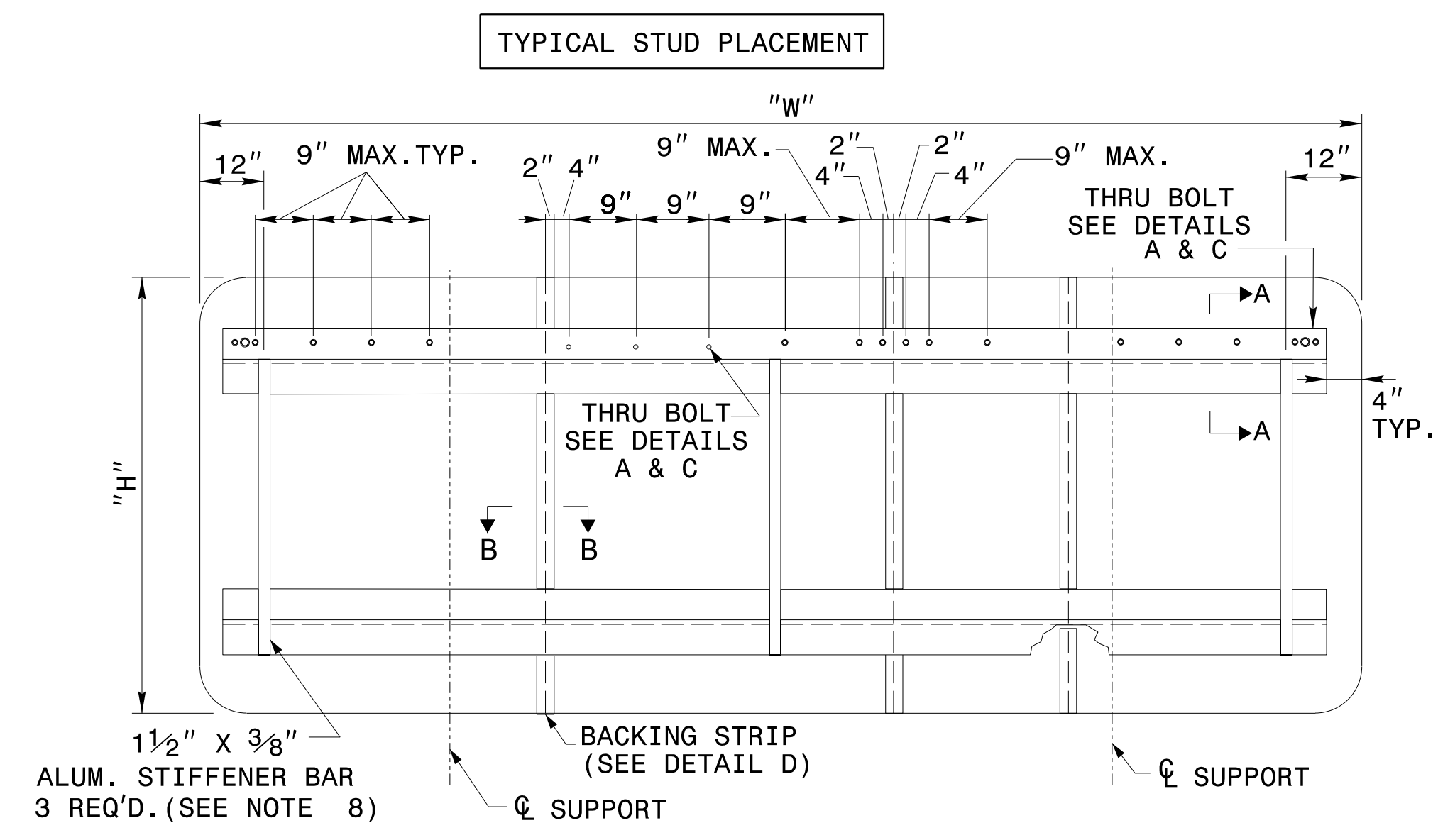

NOTES:

1. USE THE NUMBER AND SIZE OF SUPPORTS SHOWN ON THE SUPPORT CHART IN PROJECT PLANS.
2. FABRICATE SIGN PANEL SECTIONS WITH SHEETS 4'-0" WIDE. WHEN FABRICATING SIGNS WHICH ARE NOT MULTIPLES OF 4'-0" IN WIDTH, DO NOT CUT MORE THAN TWO SHEETS TO LESS THAN 4'-0" IN WIDTH. THESE PANELS SHALL NOT BE LESS THAN 1'-0" IN WIDTH.
3. SEE NCDOT STANDARD SPECIFICATIONS FOR ROADS AND STRUCTURES, FOR TYPE OF MATERIAL TO BE USED FOR SIGN PANELS, HANGER ASSEMBLIES, AND SUPPORTS.
4. USE GALVANIZED STEEL FOR BACKING PLATES AND MOUNTING BOLTS.
5. SEE ROADWAY STANDARD 904.20 WHEN TYPE "B" SECONDARY SIGN MOUNTING IS REQUIRED.
6. DETAILS FOR TYPE "A" SECONDARY SIGNS SHALL BE THE SAME AS FOR TYPE "A" SIGNS.
7. THE VERTICAL DIMENSION BETWEEN PRIMARY AND SECONDARY SIGNS IS TWO (2) INCHES.
8. ADJUST STIFFENERS TO AVOID CONFLICT WITH SUPPORTS.
9. SEE ROADWAY STANDARD 901.70 FOR SUPPORT AND "Z" BAR SPACING.
10. FABRICATE SIGNS TALLER THAN 12'-0" AS TWO SEPARATE SIGNS WITH A HORIZONTAL SPLICE. LOCATE STRINGERS ON EACH SECTION OF THE SIGN BY THE SIGN STRINGER CHART. (SEE ROADWAY STANDARD 901.70)
11. FABRICATE SIGNS TALLER THAN 12'-0" BUT SHORTER THAN 14'-6" WITH A HORIZONTAL SPLICE LOCATED 7'-0" FROM BOTTOM OF SIGN.
12. FABRICATE SIGNS 14'-6" TALL AND TALLER WITH A HORIZONTAL SPLICE. LOCATE THE SPLICE AT LEAST HALF OF THE SIGN HEIGHT FROM THE BOTTOM AND AT LEAST 7'-0" FROM THE TOP.
13. THERE SHALL ONLY BE A 1/8" GAP BETWEEN THE VERTICAL BACKING STRIP AND THE "Z" BAR.
14. SEE ROADWAY STANDARD 901.80 FOR DETAILS SHOWING SIGN MOUNTING TO SUPPORTS.
15. PLACE NYLON WASHER UNDER HEAD OF 3/8" THRU BOLTS.
16. FABRICATE EACH SIGN WITH 3/8" DIA. THRU BOLT, 4" FROM EACH END OF EACH "Z" BAR THRU SIGN PANEL AND "Z" BAR. SEE DETAILS A & C.
17. FABRICATE EACH SIGN WITH 3/8" DIA. THRU BOLT CENTERED IN EACH PANEL THRU THE TOP AND BOTTOM "Z" BAR. CENTERED THRU BOLT REQUIRED IN END PANELS GREATER THAN 2'-0" WIDE. SEE DETAILS A & C.
18. THRU BOLTS WILL HAVE A MINIMUM 1/16" TO MAXIMUM 1/8" GAP

STATE OF NORTH CAROLINA  
DEPT. OF TRANSPORTATION  
DIVISION OF HIGHWAYS  
RALEIGH, N.C.

2-19

ENGLISH DETAIL DRAWING FOR  
**TYPE 'A' SIGNS**  
WELDED STUD CONSTRUCTION

SHEET 1 OF 2

**901D10**

**REVISED SIGNING  
ROADWAY STANDARD DRAWING**