

PLAN

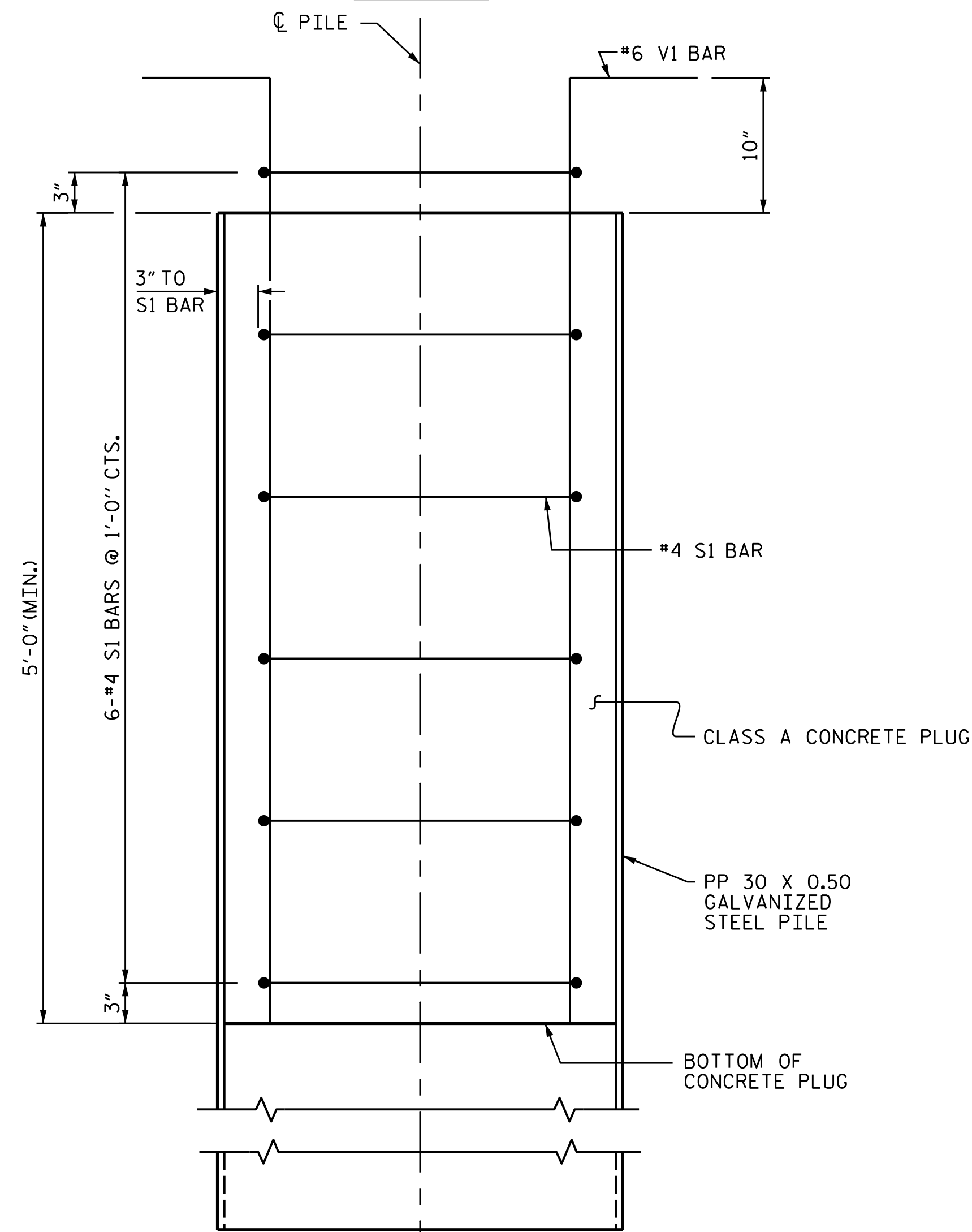

ELEVATION

PP 30 X 0.50 GALVANIZED STEEL PILE
(OPEN END)

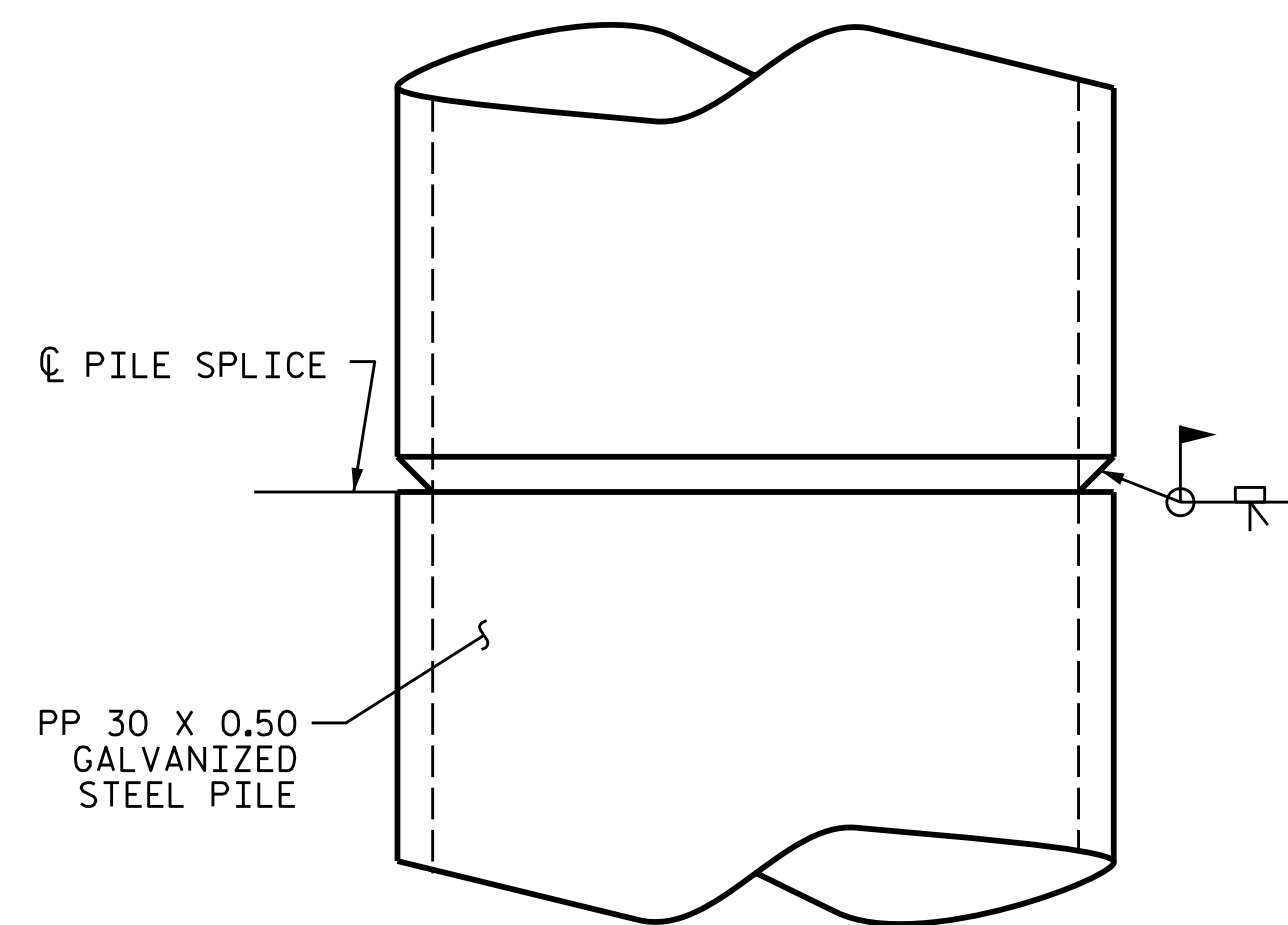

PIPE PILE SPLICE DETAIL

NOTES

PIPE PILES SHALL BE IN ACCORDANCE WITH SECTION 1084 OF THE STANDARD SPECIFICATIONS.

GALVANIZE STEEL PIPE PILES IN ACCORDANCE WITH SECTION 1076 OF THE STANDARD SPECIFICATIONS UNLESS METALLIZING IS REQUIRED. GALVANIZING OR METALLIZING PIPE PILE PLATES IS NOT REQUIRED.

REMOVE AND REPLACE OR REPAIR TO THE SATISFACTION OF THE ENGINEER PILES THAT ARE DAMAGED, DEFORMED OR COLLAPSED DURING INSTALLATION OR DRIVING.

PILE SPLICES SHALL BE IN ACCORDANCE WITH THE STANDARD SPECIFICATIONS AND AWS D1.1.

FOR OPEN END PIPE PILES, REMOVE ENOUGH SOIL AND WATER FROM INSIDE THE PILES TO CONSTRUCT THE CONCRETE PLUG WITHOUT FOULING THE CONCRETE.

FORM THE CONCRETE PLUG SUCH THAT THE REINFORCING STEEL OR CONCRETE DOES NOT MOVE AND THE CLEARANCE FROM THE REINFORCING STEEL TO THE INSIDE OF THE PILE IS MAINTAINED AFTER CONCRETE PLACEMENT. DO NOT PLACE CONCRETE IN THE BENT CAP UNTIL THE CONCRETE PLUG HAS ATTAINED A MINIMUM COMPRESSIVE STRENGTH OF 1500 PSI.

THE REINFORCING STEEL, CLASS A CONCRETE, AND GALVANIZING ARE CONSIDERED INCIDENTAL TO THE CONTRACT UNIT PRICE BID PER LINEAR FOOT FOR PP 30 X 0.50 GALVANIZED STEEL PILES.

BILL OF MATERIAL FOR ONE
PP 30 X 0.50 GALVANIZED STEEL PILE

BAR	NO.	SIZE	TYPE	LENGTH	WEIGHT
S1	6	#4	1	7'-7"	30
V1	16	#6	2	6'-10"	164
REINFORCING STEEL =				194	lbs

CLASS A CONCRETE

5'-0" MINIMUM PLUG 0.8 CY

BAR TYPES

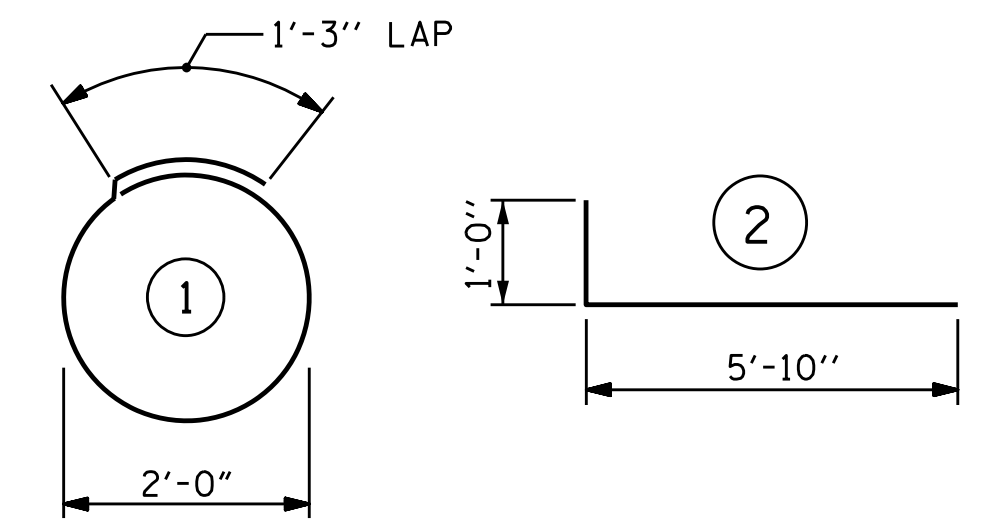

ALL BAR DIMENSIONS ARE OUT TO OUT.

PROJECT NO. B-5703
CUMBERLAND/HARNETT COUNTY
STATION: 16+92.70 -L-

STATE OF NORTH CAROLINA
DEPARTMENT OF TRANSPORTATION
RALEIGH

STANDARD
30" STEEL PIPE PILE

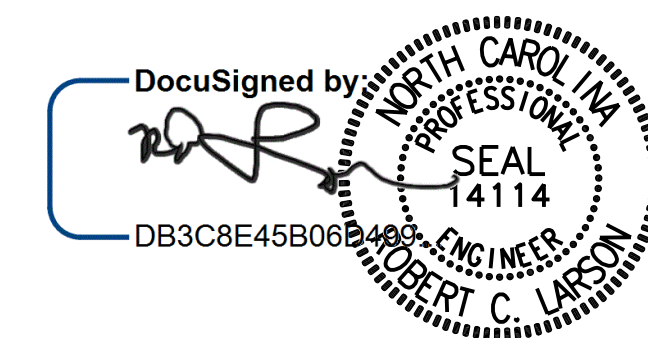

7/1/2021

REVISIONS

NO.	BY:	DATE:	NO.	BY:	DATE:	SHEET NO.
1			3			S-26
2			4			TOTAL SHEETS 29

DOCUMENT NOT CONSIDERED FINAL
UNLESS ALL SIGNATURES COMPLETED



STD. NO. SPP5

KCI JOB NO: 251801945.13

DESIGN ENGINEER OF RECORD	DocuSigned by	DATE :
ASSEMBLED BY : R. C. LARSON	DATE : 11/30/20	
CHECKED BY : K. SU	DATE : 12/01/20	
DRAWN BY : TLA 8/05	REV. 5/1/06R	MAA/KMM
CHECKED BY : GM 9/05	REV. 10/1/11	MAA/GM
	REV. 12/17	MAA/THC