

PLAN OF CAP

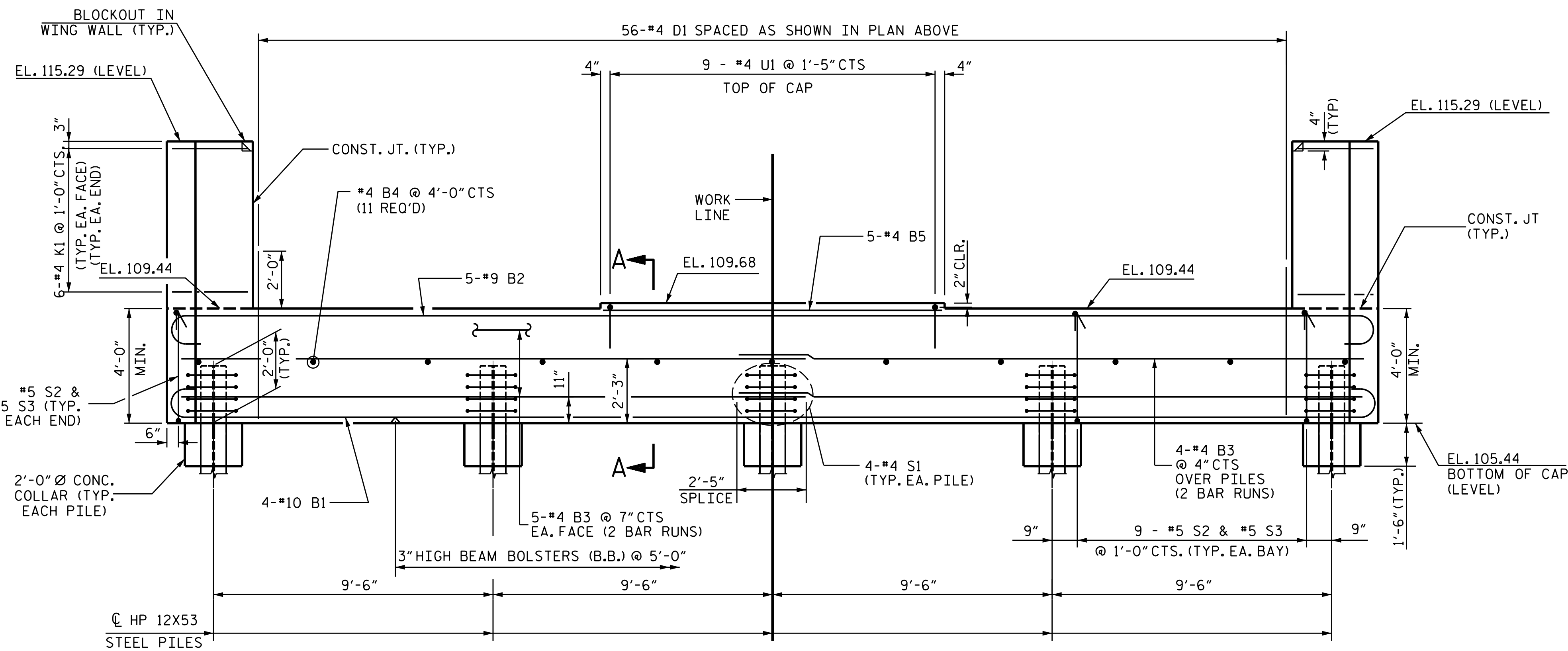

ELEVATION

NOTES

- THE TOP SURFACE OF THE END BENT CAP AND WINGS (POUR 1) EXCEPT THE BEARING AREA AND THE AREA OUTSIDE OF THE SUPERSTRUCTURE SHALL BE RAKED TO A DEPTH OF 1/4"
- FOR "TEMPORARY DRAINAGE AT END BENT", SEE END BENT 2.
- FOR SECTION A-A SEE SHEET 3 OF 3.
- STIRRUPS IN CAP MAY BE SHIFTED AS NECESSARY TO CLEAR #4 D1 BARS.
- THE UPPER PORTION OF THE INTEGRAL END BENT SHALL BE POURED WITH THE SUPERSTRUCTURE. SEE SUPERSTRUCTURE PLANS.

PROJECT NO. B-5703
CUMBERLAND/HARNETT COUNTY
 STATION: 16+92.70 -L-

SHEET 1 OF 3

STATE OF NORTH CAROLINA
 DEPARTMENT OF TRANSPORTATION
 RALEIGH

**SUBSTRUCTURE
 END BENT 1
 (INTEGRAL)**

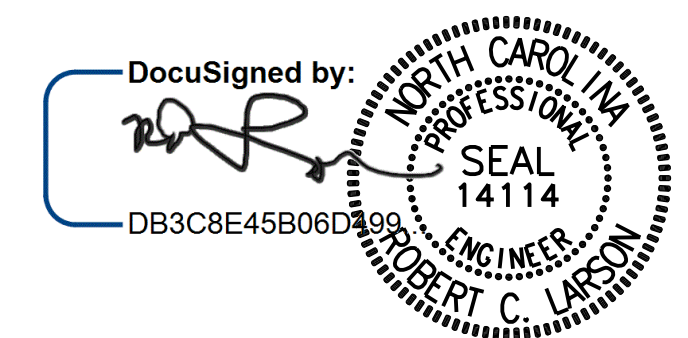

DESIGN ENGINEER OF RECORD: [Signature] DATE: 7/1/2021
 DRAWN BY: F. A. BARHAM DATE: 02/28/19
 CHECKED BY: R. C. LARSON DATE: 09/20/20

**DOCUMENT NOT CONSIDERED FINAL
 UNLESS ALL SIGNATURES COMPLETED**

REVISIONS		SHEET NO.	
NO.	DATE	NO.	DATE
1		3	
2		4	

TOTAL SHEETS: 29

KCI JOB NO: 251801945.13