

Note:
 1. Opening in pole base plate shall be equal to pole base inside diameter minus 3 1/2" but shall not be less than 8 1/2".

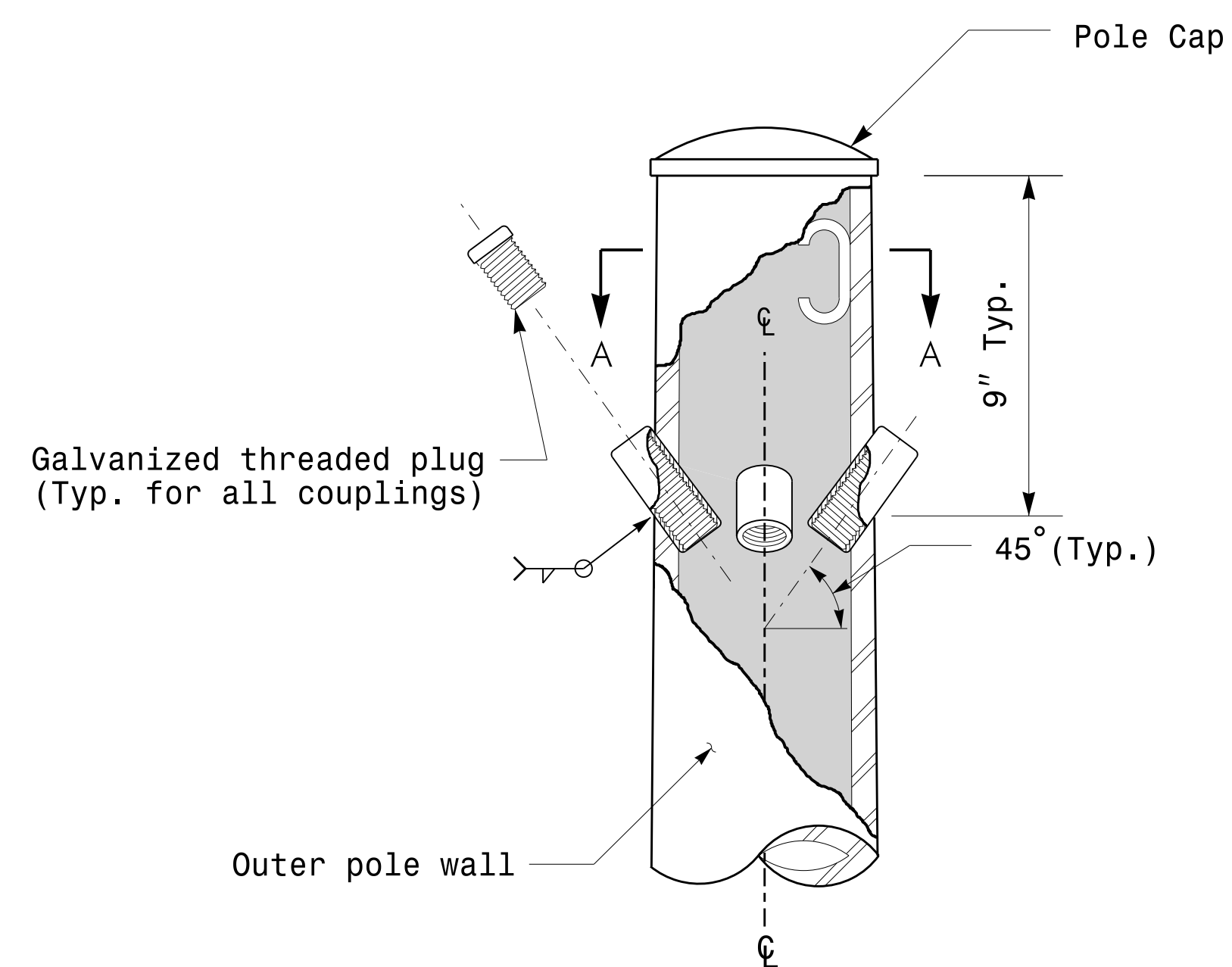

Cable Entrances at Top of Pole

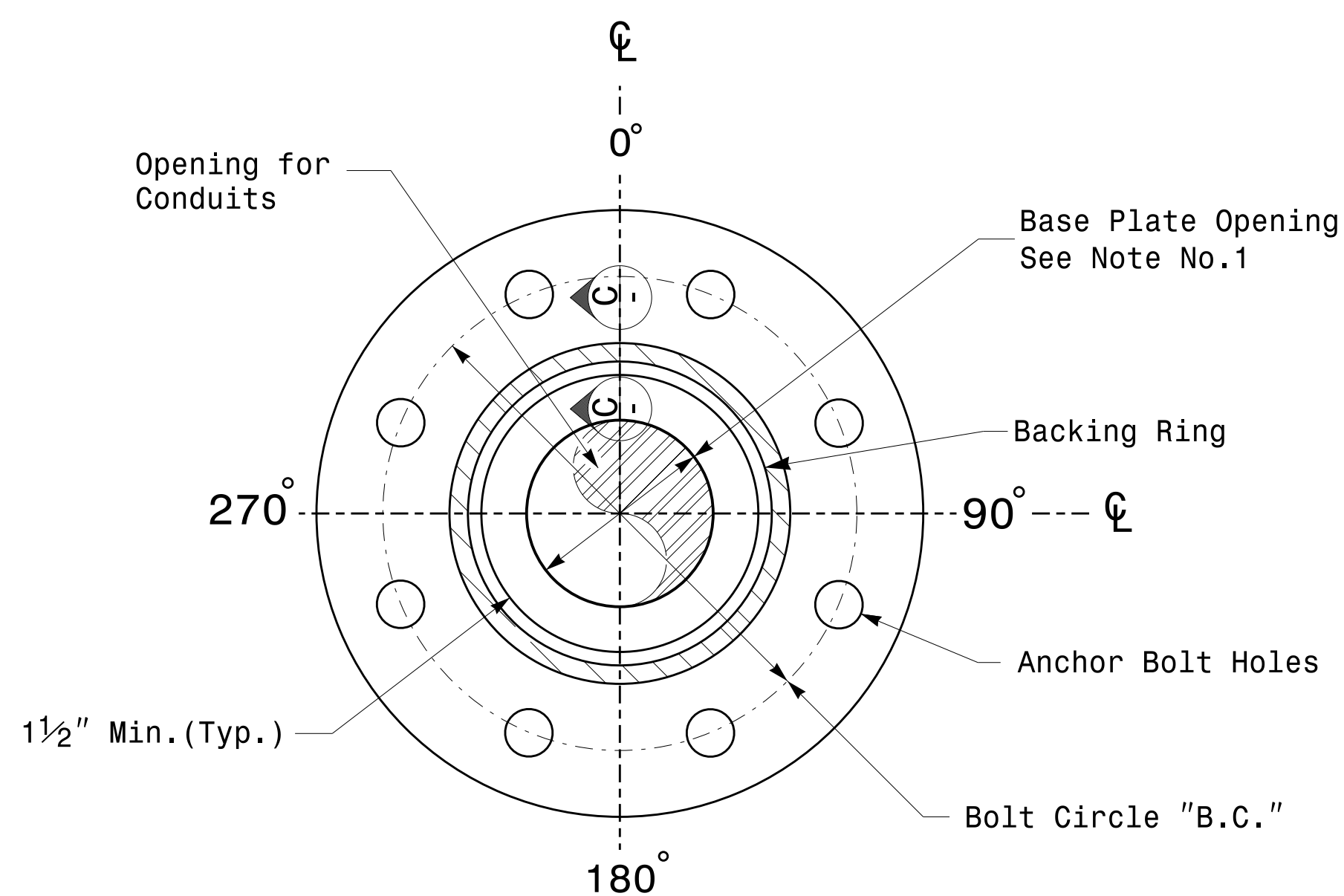

Section B-B
Pole Base Plate Details
(8 and 12 Bolt Pattern)

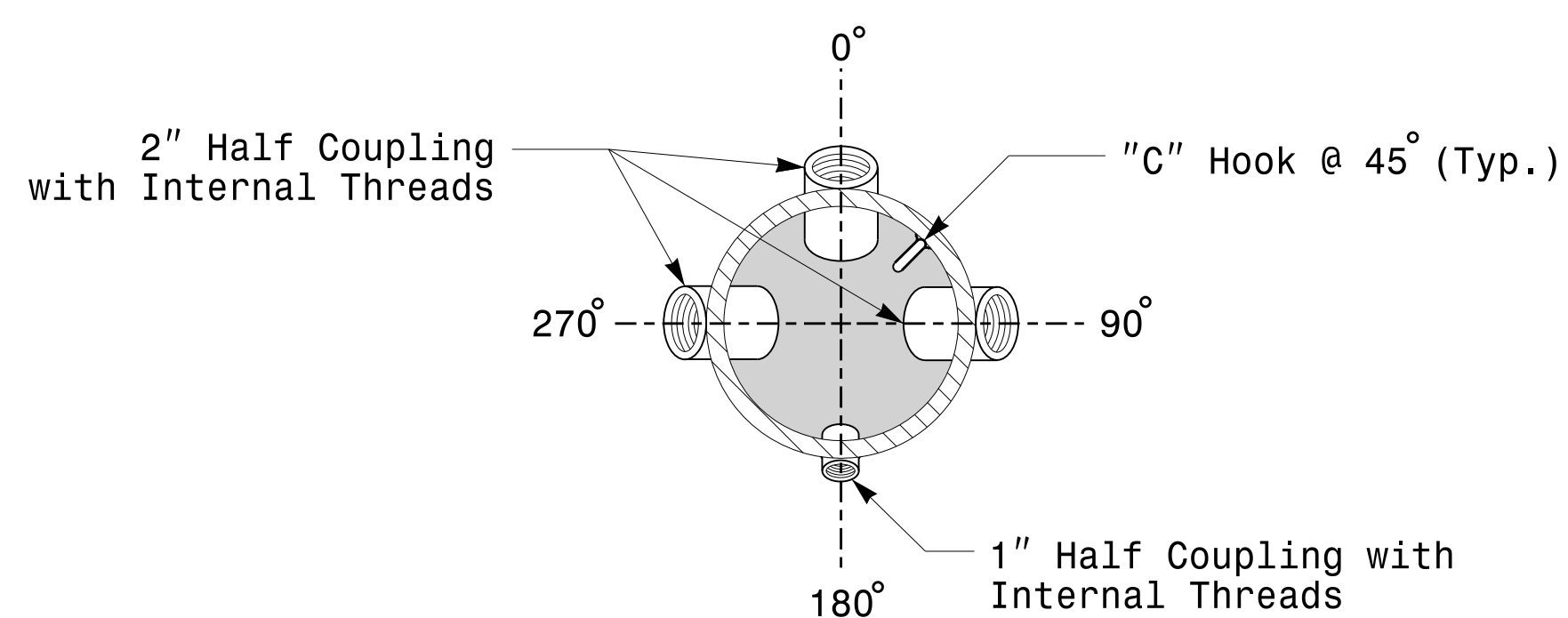

Section A-A
Radial Orientation for Factory Installed
Accessories at Top of Pole

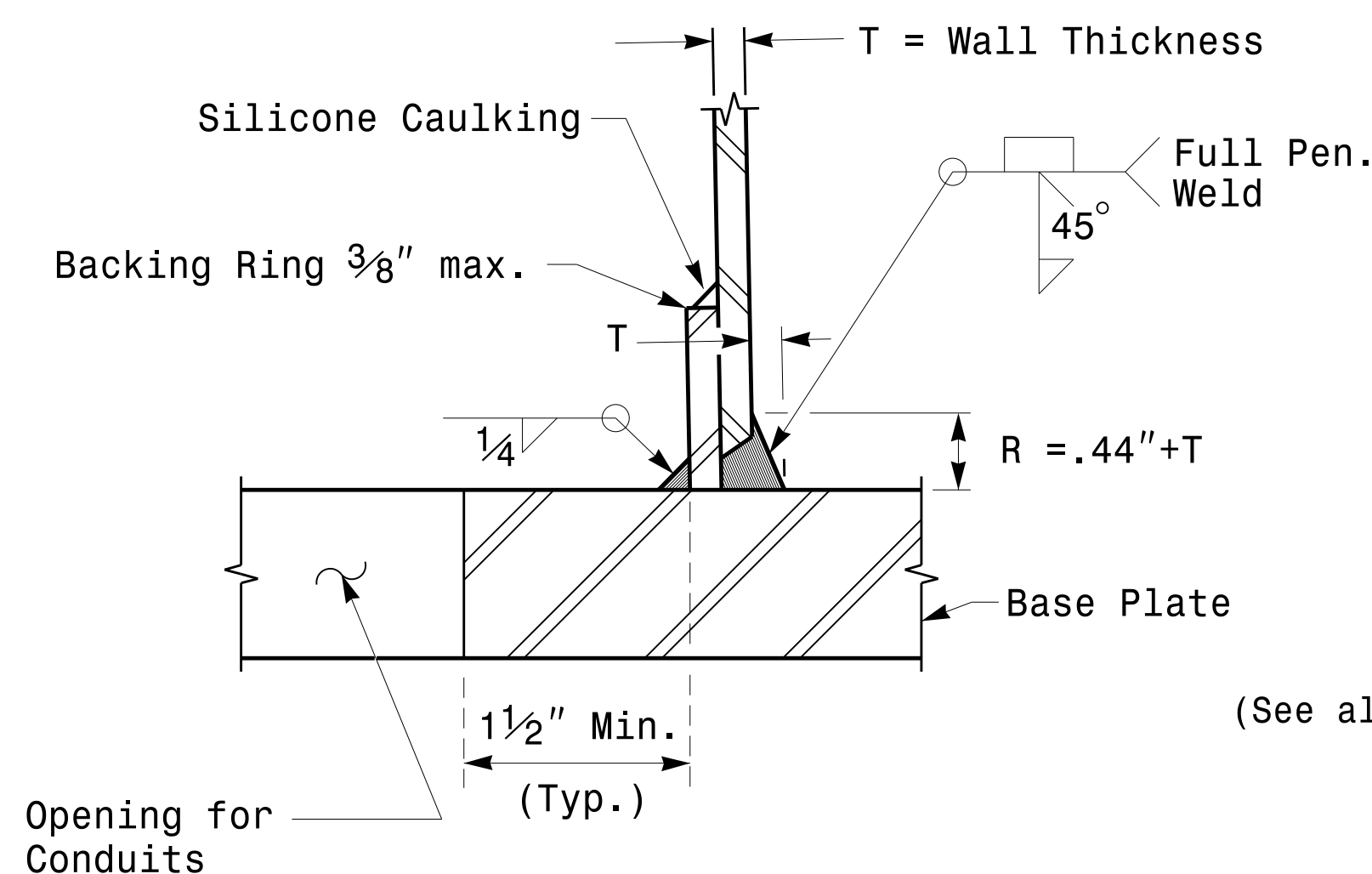

Section C-C
(Pole Attachment to Base Plate)
Full-Penetration
Groove Weld Detail

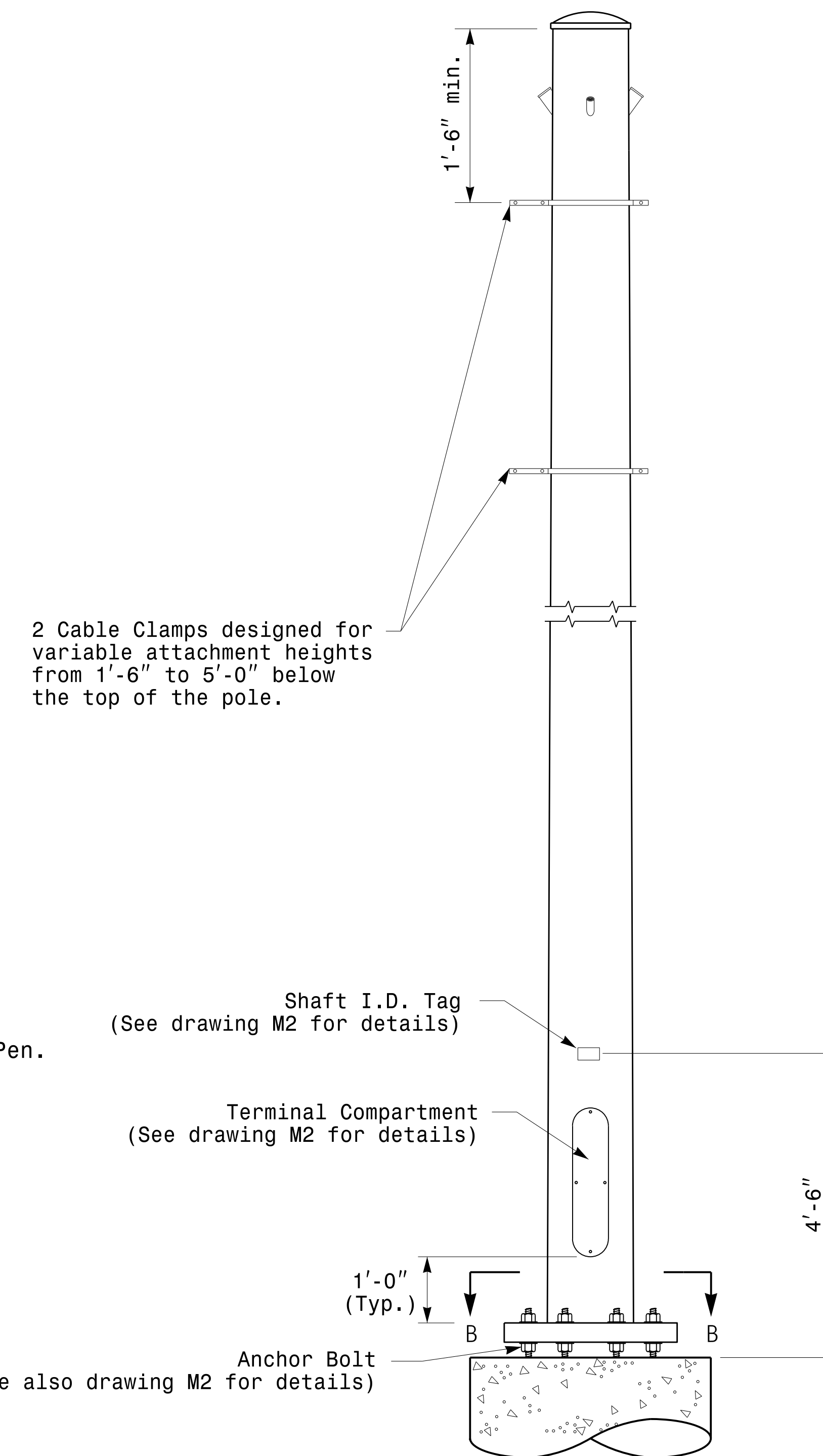

Monotube Strain Pole

<p>750 N. Greenfield Pkwy, Garner, NC 27529</p>	<p>Typical Fabrication Details For Strain Poles</p>		<p>SEAL</p> <p>DocuSigned by: <i>Dibesh C. Sarkar</i></p>
	<p>PLAN DATE: OCTOBER 2017</p>	<p>DESIGNED BY: K.C. DURIGON</p>	
<p>SCALE: NONE</p>	<p>PREPARED BY: N. BITTING</p>	<p>REVIEWED BY: D.C. SARKAR</p>	<p>DATE: 10/11/2017</p>

Fabrication Details – Strain Poles