

10/18/2020 L:\Raleigh Office Projects\Structures\2018\188906-05 NCDOT - 640021 New Hanover Co\05 Plans\1.0 DGN\401.285.15BPR.19_SMJ.Std.CPR01.S-56.dgn

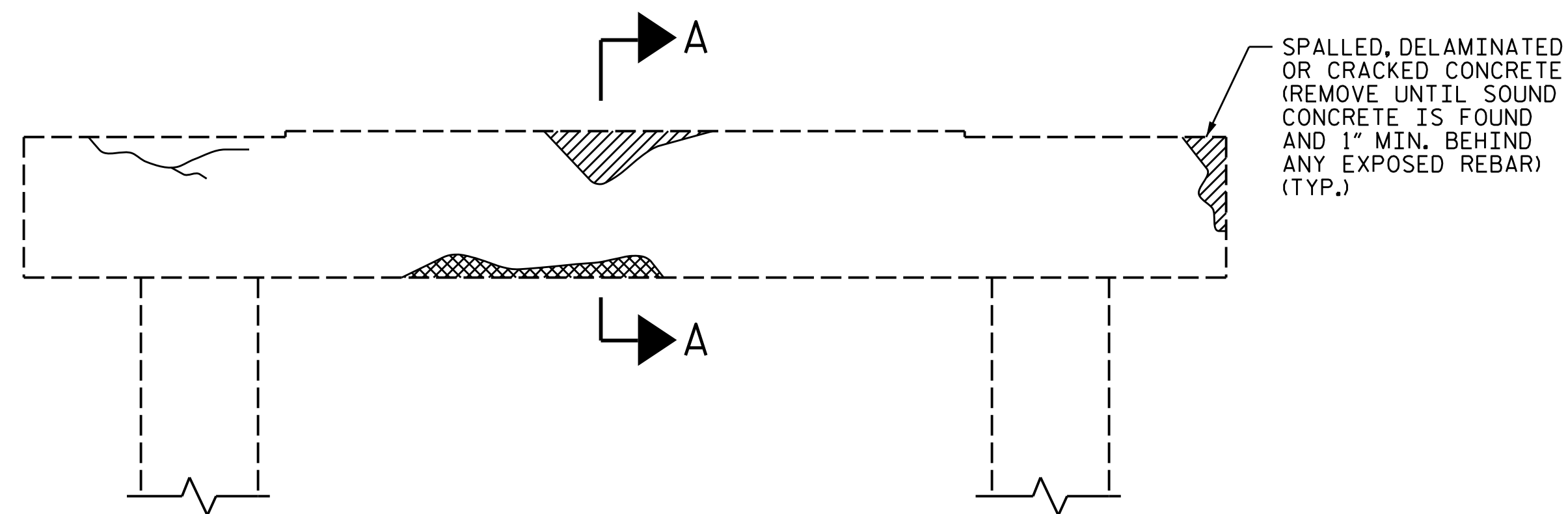

BENT CAP REPAIRS

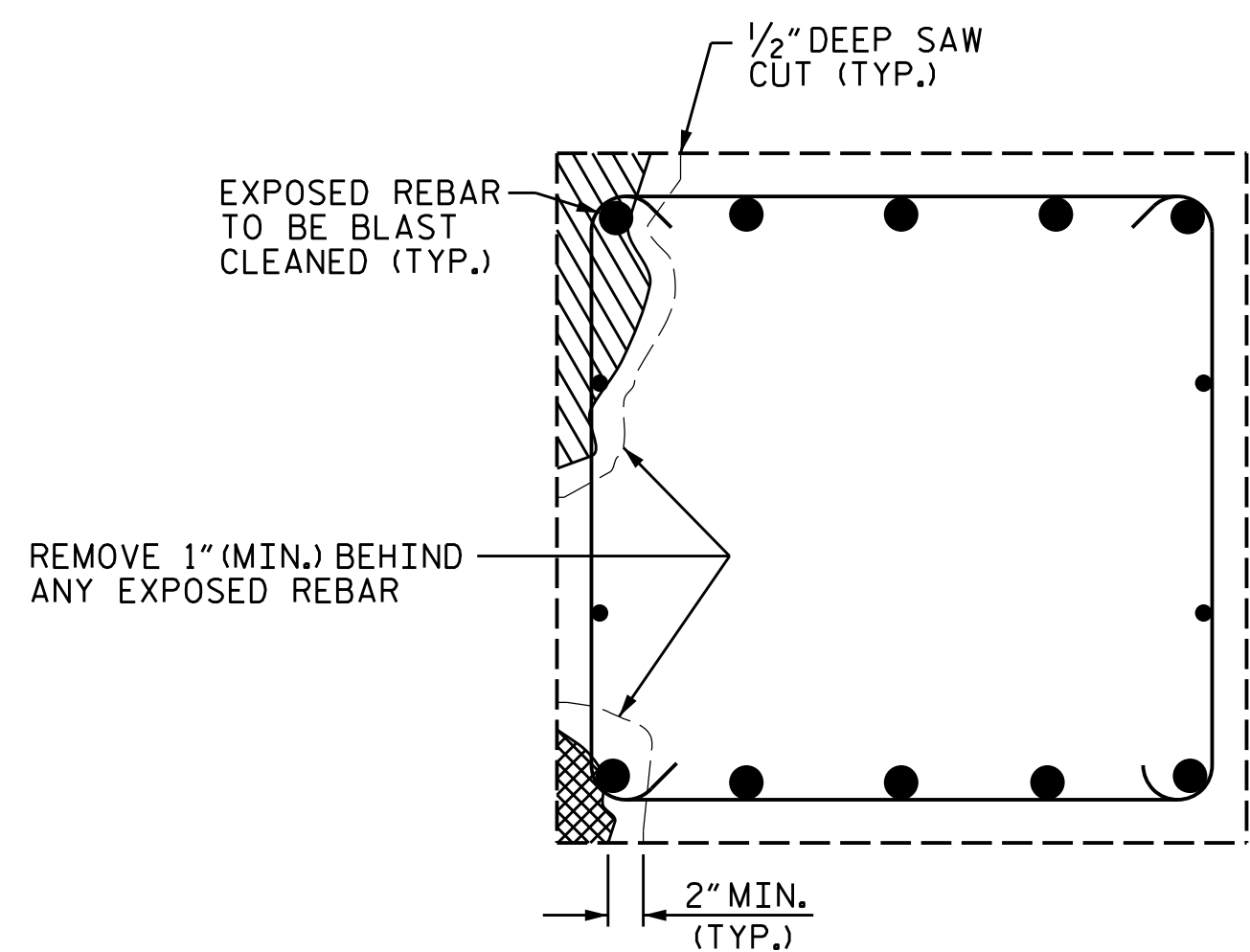

SECTION A-A

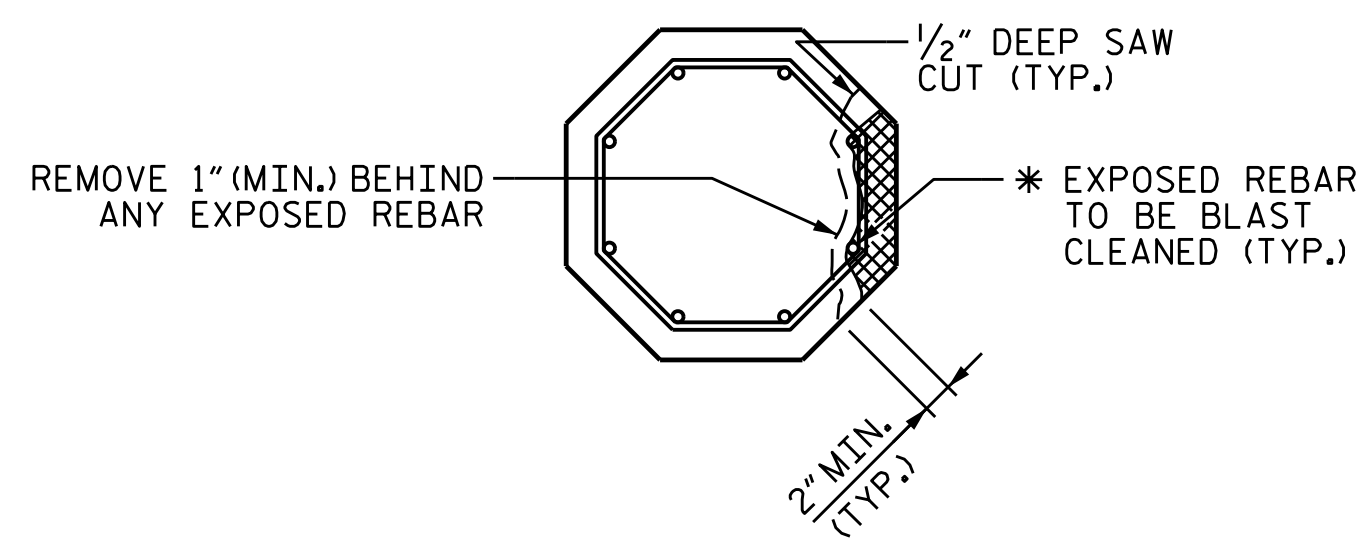

PLAN OF PILE

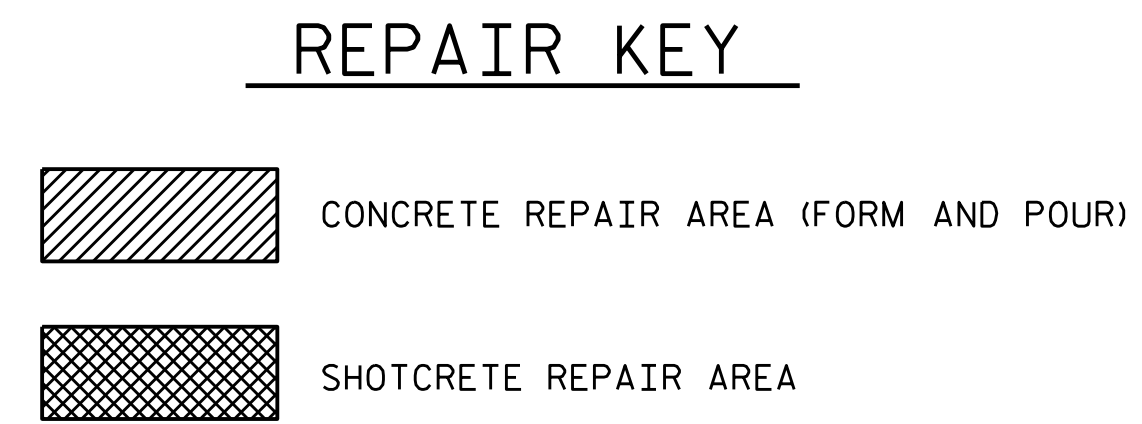

SPLICE LENGTH TABLE		
BAR SIZE	MIN. SPLICE LENGTH	
#4	2'-4"	
#5	2'-9"	
#6	4'-0"	
#7	5'-3"	
#8	6'-9"	
#9	8'-6"	
#10	10'-11"	
#11	13'-4"	

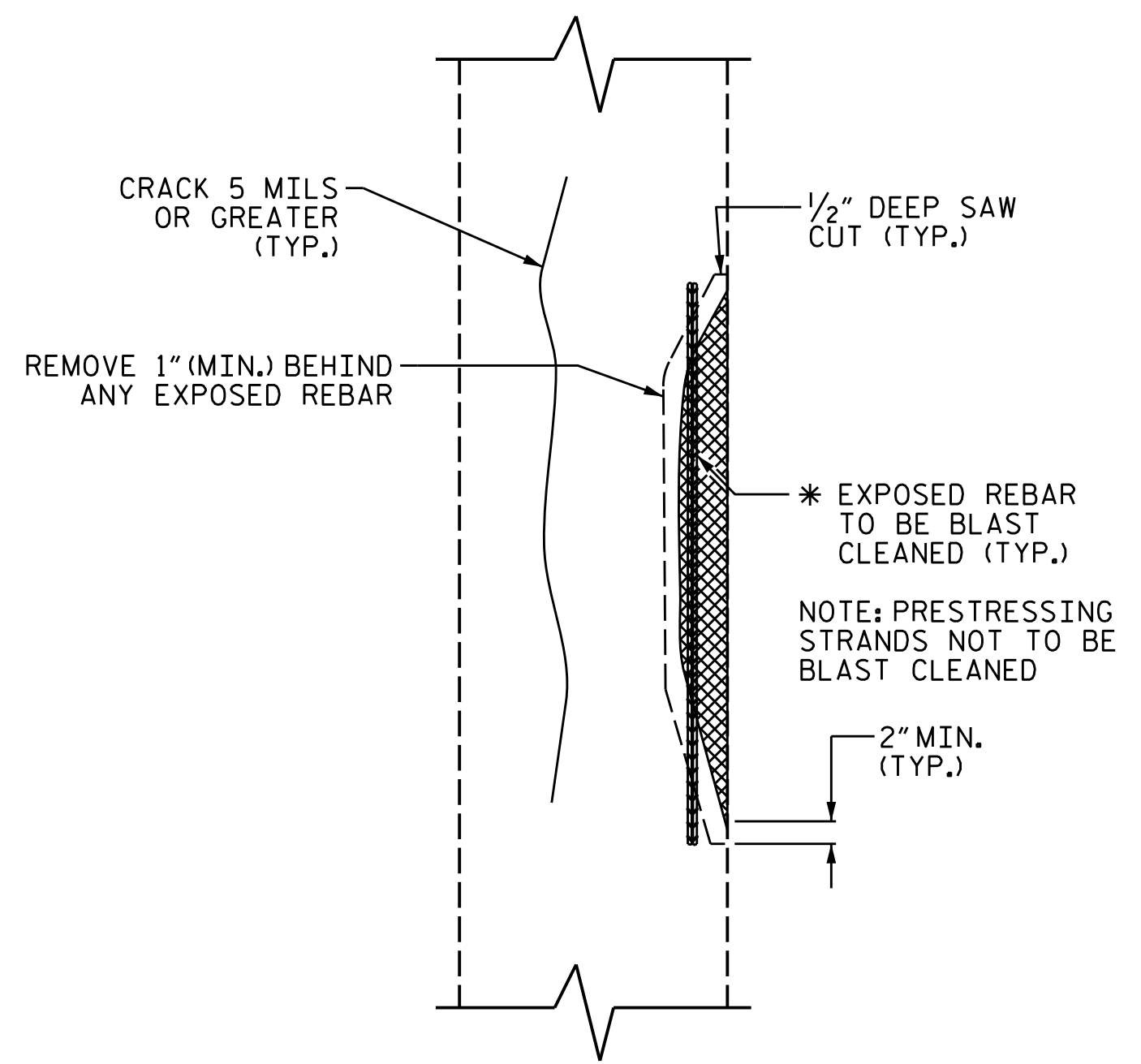

ELEVATION OF PILE

PILE REPAIR

* REPAIR LENGTH SHALL NOT EXCEED 10 FEET.

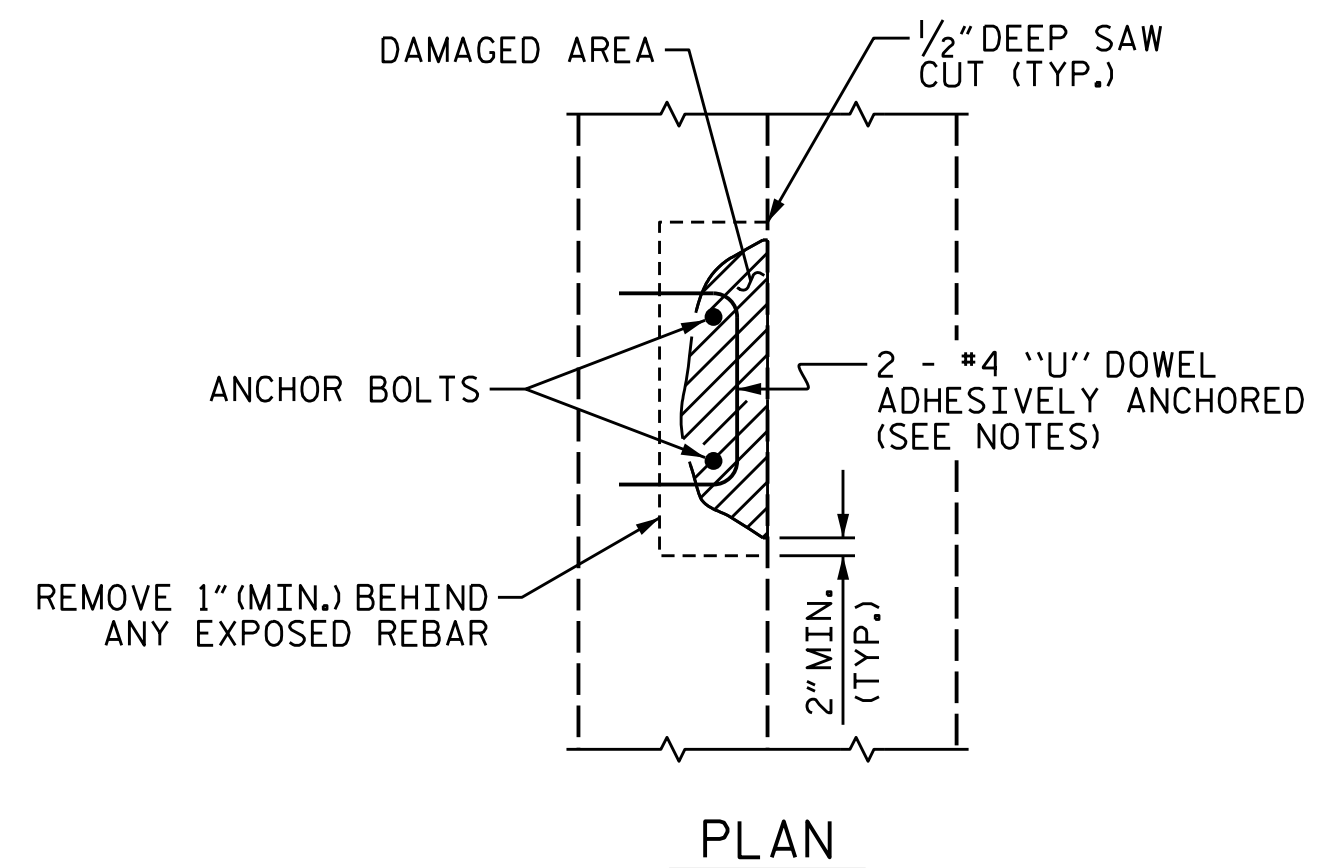

PLAN

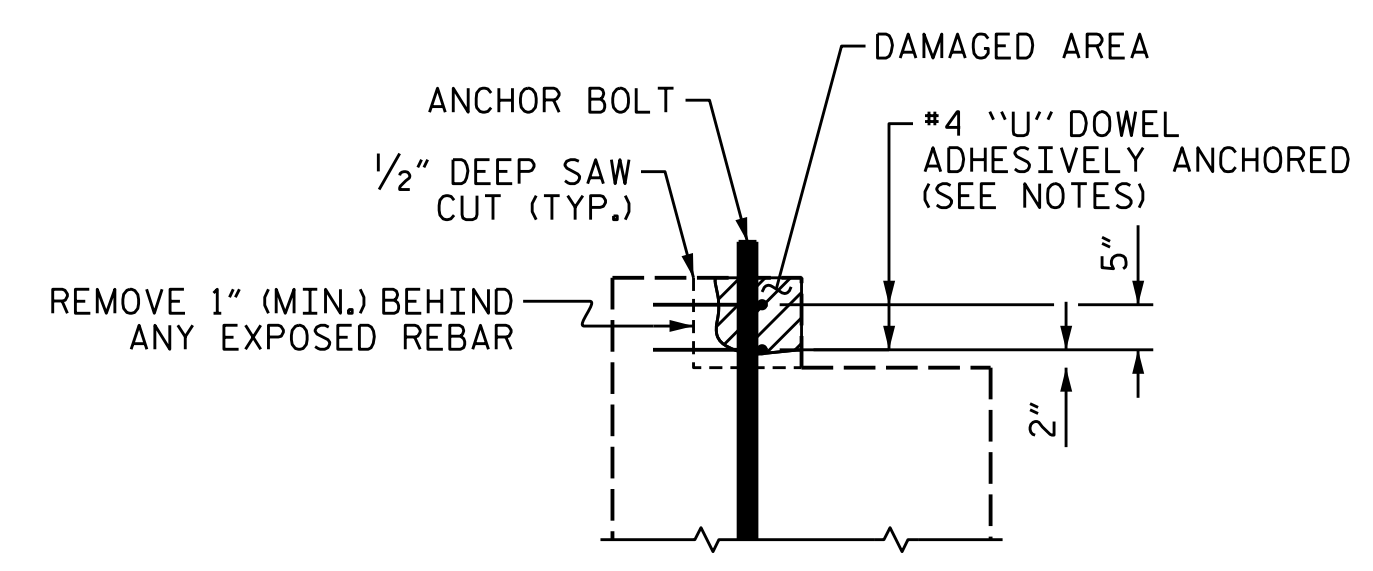

ELEVATION

PEDESTAL WALL REPAIR

NOTES

TYPICAL BENT CAP REPAIRS ARE SHOWN, REPAIR DETAILS SIMILAR FOR END BENT CAPS AND STRUTS.

THE METHOD USED TO DELINEATE THE AREAS OF UNSOUND CONCRETE TO BE REPAIRED SHALL NOT PERMANENTLY MARK THE CONCRETE, LEAVE ANY RESIDUE AFTER REMOVAL OR REQUIRE HARSH CHEMICALS TO REMOVE.

THE CONTRACTOR SHALL REMOVE THE DETERIORATED CONCRETE IN ACCORDANCE WITH THE GUIDELINES SET IN THESE NOTES, IN THE SPECIAL PROVISIONS AND THE STANDARD SPECIFICATIONS.

REMOVE UNSOUND CONCRETE TO THE EXTENT NECESSARY, MINIMUM OF 1" BEHIND REBAR AND MINIMUM OF 2" CLEARANCE TO SAWCUT.

NO MORE THAN ONE-THIRD OF THE CAP OR PILE CIRCUMFERENCE SHALL BE REMOVED AT ONE TIME, SHOULD IT BECOME NECESSARY TO REMOVE MORE THAN 30% OF A CAP OR PILE CROSS SECTIONAL AREA, NOTIFY THE ENGINEER PRIOR TO PROCEEDING.

SIMULTANEOUS REMOVAL OF UNSOUND CONCRETE MAY BE PERMITTED ON MORE THAN ONE FACE OF A CAP AND/OR PILE, BUT NO MORE THAN 1/3 OF THE CIRCUMFERENCE SHALL BE REMOVED AT ONE TIME. IF REMOVAL EXTENDS MORE THAN 1/2" BEHIND THE MAIN REINFORCING, NOTIFY THE ENGINEER PRIOR TO PROCEEDING.

ON COLUMNS AND PILES, NO MORE THAN 10 VERTICAL FEET MAY BE EXPOSED AT ONE TIME BEFORE PLACEMENT OF REPAIR CONCRETE.

REINFORCING STEEL WHICH IS DETERMINED BY THE ENGINEER TO BE REPLACED, SHALL BE REMOVED TO A POINT WHERE IT IS SOUND. THE PATCH SHALL EXTEND A SUFFICIENT DISTANCE BEYOND THIS POINT TO DEVELOP A SPLICE LENGTH SPECIFIED IN THE TABLE ON THIS SHEET.

THE #4 "U" DOWELS ARE REQUIRED ONLY AROUND THE ANCHOR BOLTS. THE EXISTING REINFORCING STEEL IN THE PEDESTAL WALL SHALL BE CLEANED, STRAIGHTENED AND REMAIN IN PLACE.

FOR ADHESIVELY ANCHORED ANCHOR BOLTS OR DOWELS, SEE STANDARD SPECIFICATIONS.

COAT ALL REPAIR SURFACE AREAS ON THE TOP OF CAPS, INCLUDING CHAMFERS, WITH EPOXY PROTECTIVE COATING, OVERLAPPING THE REPAIR AREA BY A MINIMUM OF 3" ON ALL POSSIBLE SIDES.

FOR SHOTCRETE REPAIRS, SEE SPECIAL PROVISIONS.

FOR CONCRETE REPAIRS, SEE SPECIAL PROVISIONS.

FOR EPOXY PROTECTIVE COATING, SEE SPECIAL PROVISIONS.

CLEAN ALL EXPOSED REINFORCING BARS AND PRESTRESSED STRANDS IN ACCORDANCE WITH APPROPRIATE SPECIAL PROVISIONS. FOR BARS WITH MORE THAN 10% SECTION LOSS, SPLICE AND SECURELY TIE SUPPLEMENTAL REINFORCING BARS AS NEEDED. NOTE AND PROVIDE DETAILED DOCUMENTATION, INCLUDING LOCATION AND SEVERITY, OF ALL DAMAGE TO PRESTRESSED STRANDS THAT EXCEEDS 10% SECTION LOSS. IF FIVE OR MORE STRANDS ARE DAMAGED, NOTIFY THE ENGINEER PRIOR TO PLACEMENT OF REPAIR MATERIAL.

PROJECT NO. 15BPR.19
 NEW HANOVER COUNTY
 BRIDGE NO. 640021

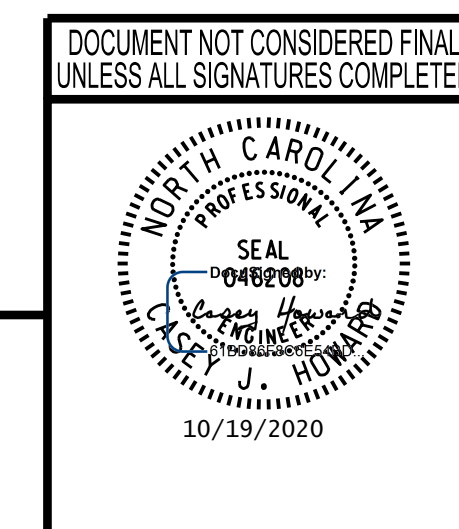

STATE OF NORTH CAROLINA
 DEPARTMENT OF TRANSPORTATION
 RALEIGH

STANDARD
 TYPICAL CAP
 AND PILE
 REPAIR DETAILS

REVISIONS						SHEET NO.
NO.	BY:	DATE:	NO.	BY:	DATE:	
1			3			TOTAL SHEETS
2			4			58

DRAWN BY: M.J. OSTRISHKO DATE: OCT 2018
 CHECKED BY: C.J. HOWARD DATE: NOV 2018

wsp WSP USA, Inc.
 434 FAYETTEVILLE STREET
 SUITE 1500
 RALEIGH, NC 27601
 TEL: 1.919.836.4040
 LICENSE NO. F-0165