

NOTES

STIRRUPS IN CAP MAY BE SHIFTED AS NECESSARY TO CLEAR DOWELS.

THE CONCRETE IN THE SHADED AREA OF THE WING SHALL BE POURED AFTER THE VERTICAL CONCRETE BARRIER RAIL IS CAST IF SLIP FORMING IS USED.

FOR PILE SPLICE DETAILS, SEE SHEET 4 OF 4.

FOR WING DETAILS, SEE SHEET 3 OF 4.

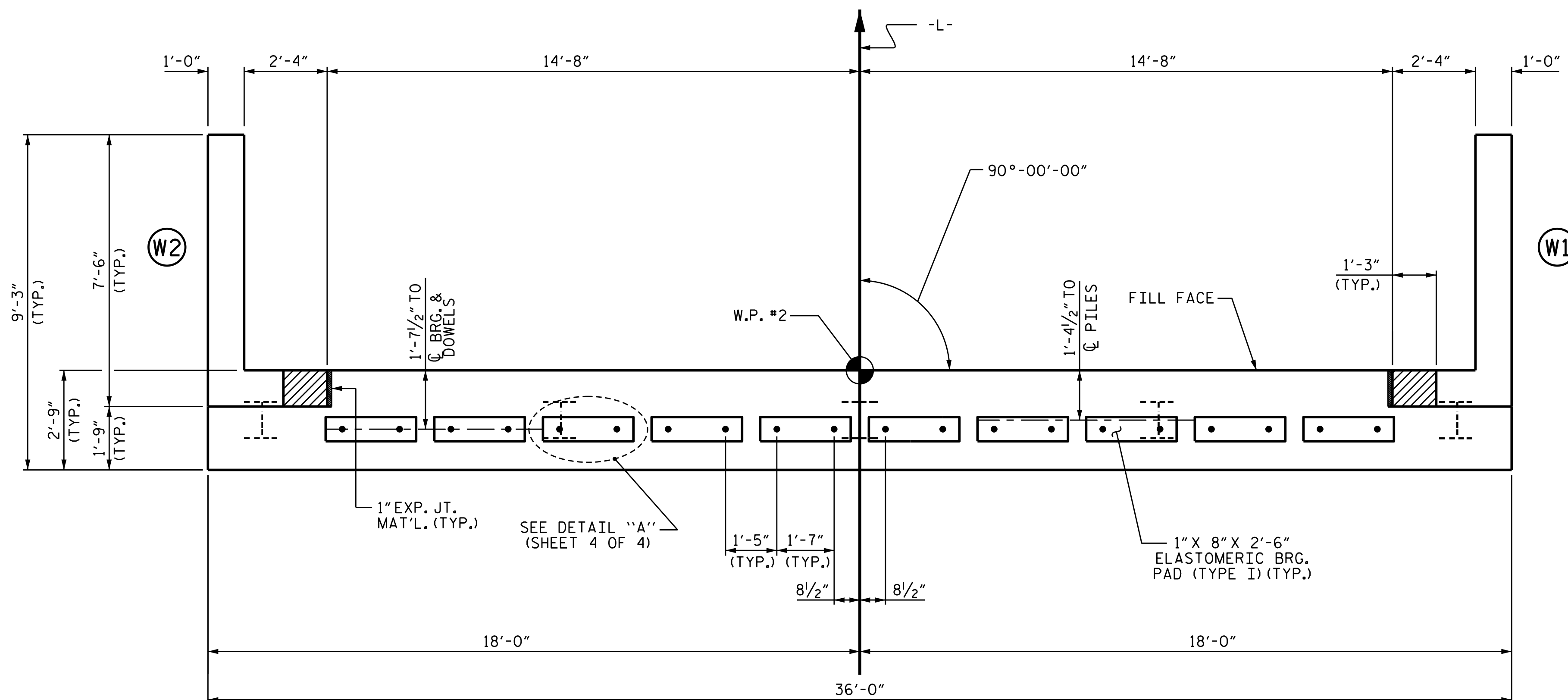

PLAN

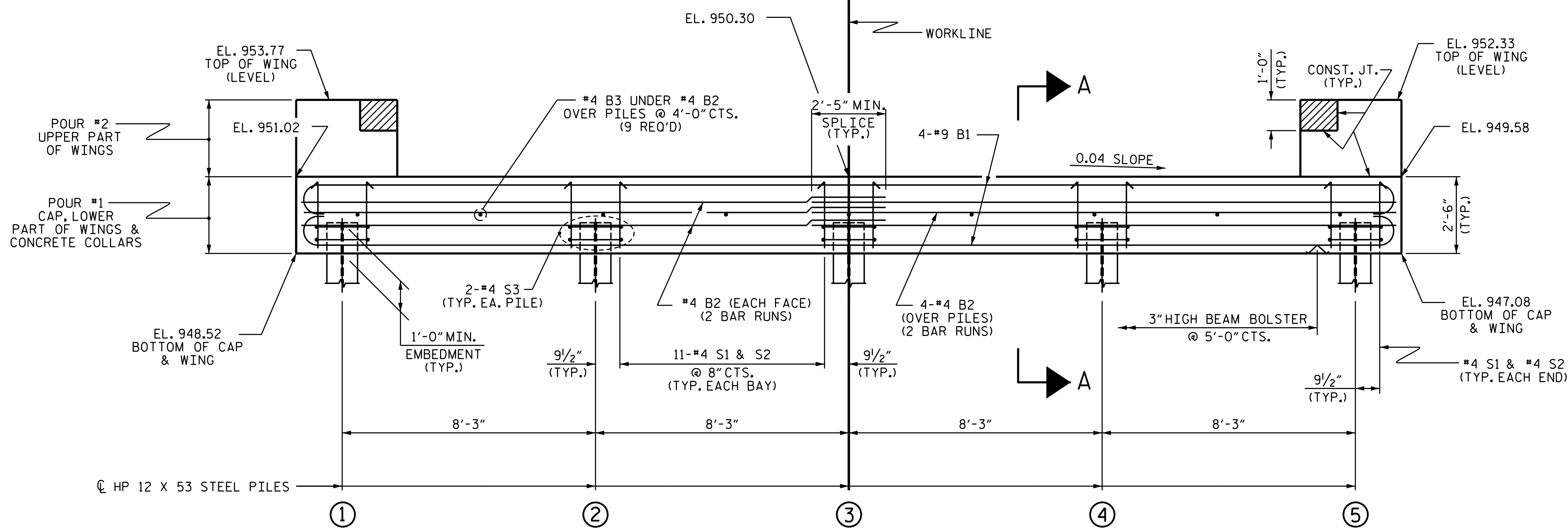

ELEVATION

TOP OF PILE ELEVATIONS	
①	949.46
②	949.13
③	948.80
④	948.47
⑤	948.14

PROJECT NO. BR-0107
IREDELL COUNTY
 STATION: 17+68.00 -L-

SHEET 2 of 4

STATE OF NORTH CAROLINA
 DEPARTMENT OF TRANSPORTATION
 RALEIGH

SUBSTRUCTURE
 END BENT No. 2

DocuSigned by:
 L. M. Samples
 5663D09A8B449C
 5/19/2021



ms consultants, inc.
 5444 Wake Park Blvd.
 Suite 160
 Raleigh, NC 27607
 NC License Number : C-3239



DOCUMENT NOT CONSIDERED
 FINAL UNLESS ALL
 SIGNATURES COMPLETED

REVISIONS						SHEET NO.
NO.	BY:	DATE:	NO.	BY:	DATE:	S-10
1			3			TOTAL SHEETS
2			4			14

ASSEMBLED BY : J.M. KEPICH DATE : 11/19
 CHECKED BY : L.M. SAMPLES DATE : 03/20
 DRAWN BY : DGE 01/10 REV. 4/15 MAA/TMC
 CHECKED BY : MKT 01/10

WINGS NOT SHOWN FOR CLARITY.
 FOR SECTION A-A, SEE SHEET 4 OF 4.
 CONCRETE COLLARS FOR STEEL PILES NOT SHOWN IN PLAN AND ELEVATION VIEWS FOR CLARITY.
 SEE "CORROSION PROTECTION FOR STEEL PILES DETAIL", SHEET 4 OF 4.