

NOTES

STIRRUPS IN CAP MAY BE SHIFTED AS NECESSARY TO CLEAR DOWELS.

THE CONCRETE IN THE SHADED AREA OF THE WING SHALL BE POURED AFTER THE VERTICAL CONCRETE BARRIER RAIL IS CAST IF SLIP FORMING IS USED.

FOR PILE SPLICE DETAILS, SEE SHEET 4 OF 4.

FOR WING DETAILS, SEE SHEET 3 OF 4.

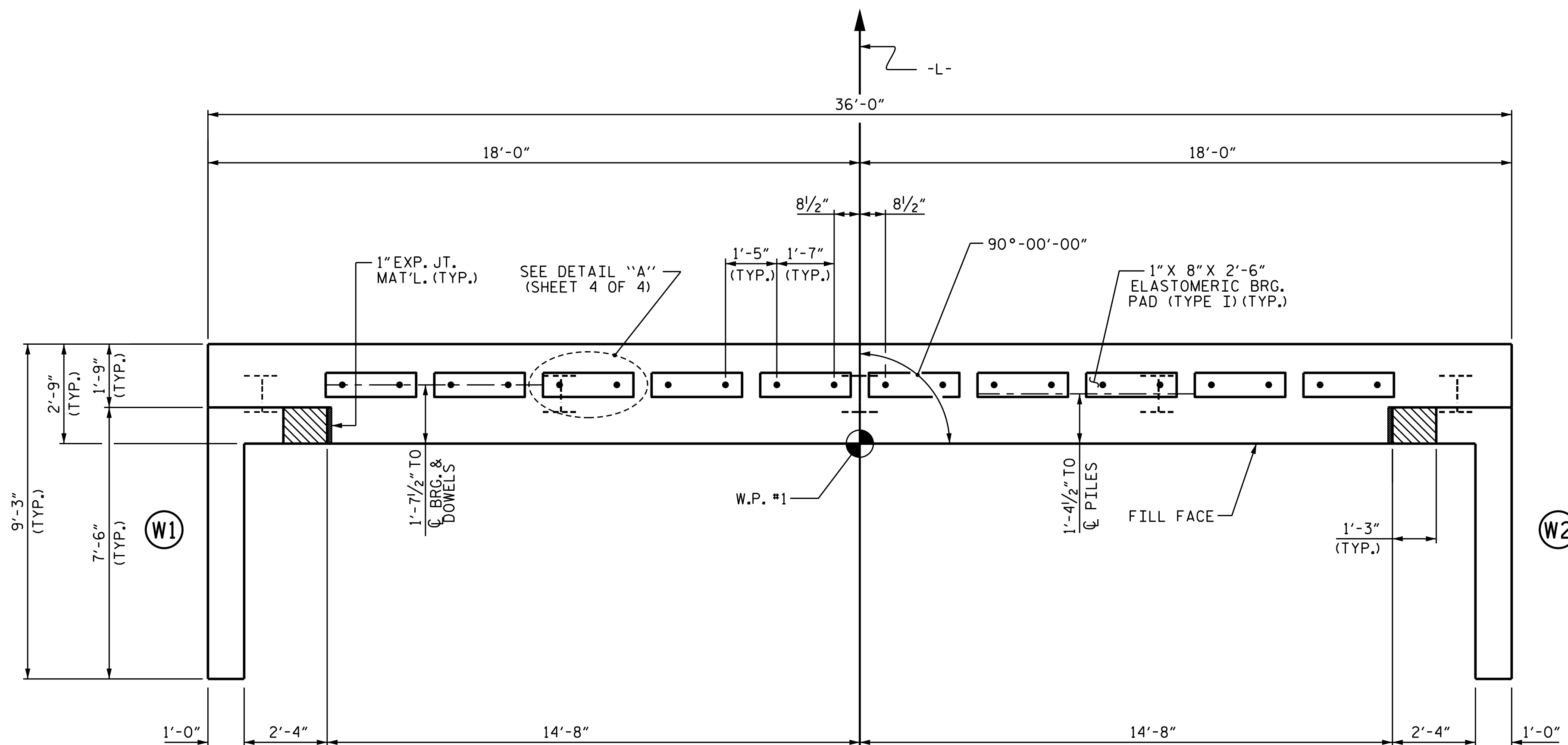

PLAN

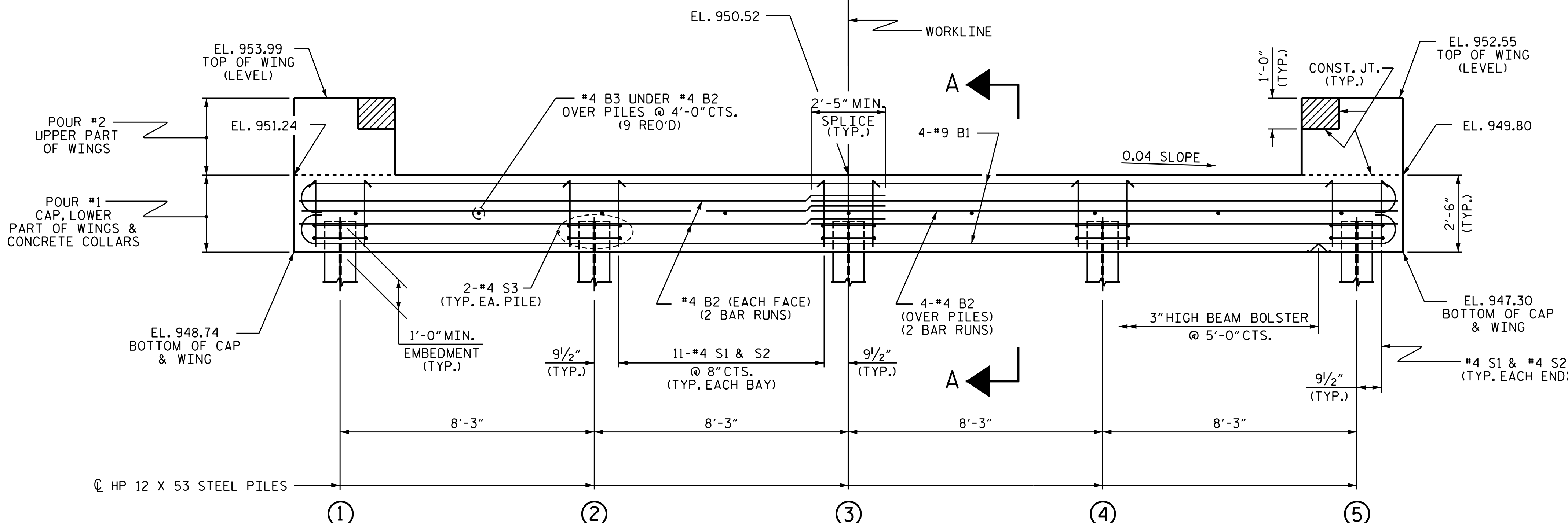

ELEVATION

WINGS NOT SHOWN FOR CLARITY.
FOR SECTION A-A, SEE SHEET 4 OF 4.
CONCRETE COLLARS FOR STEEL PILES NOT SHOWN IN PLAN AND ELEVATION VIEWS FOR CLARITY.
SEE "CORROSION PROTECTION FOR STEEL PILES DETAIL", SHEET 4 OF 4.

TOP OF PILE ELEVATIONS	
①	949.68
②	949.35
③	949.02
④	948.69
⑤	948.36

PROJECT NO. BR-0107
IREDELL COUNTY
STATION: 17+68.00 -L-

SHEET 1 of 4

STATE OF NORTH CAROLINA
DEPARTMENT OF TRANSPORTATION
RALEIGH

SUBSTRUCTURE
END BENT No. 1

DocuSigned by:
Lisa M. Samples
5663D09A8B449C
5/19/2021



ms consultants, inc.
5444 Wake Park Blvd.
Suite 160
Raleigh, NC 27607
NC License Number : C-3239



REVISIONS

NO.	BY:	DATE:	NO.	BY:	DATE:
1			3		
2			4		

SHEET NO.
S-09
TOTAL SHEETS 14

DOCUMENT NOT CONSIDERED FINAL UNLESS ALL SIGNATURES COMPLETED

ASSEMBLED BY : J.M. KEPICH	DATE : 11/19
CHECKED BY : L.M. SAMPLES	DATE : 03/20
DRAWN BY : DGE 01/10	REV. 4/15
CHECKED BY : MKT 01/10	MAA/TMC