

T.I.P.: I-5986B

CONTRACT NO.:

**STATE OF NORTH CAROLINA  
DEPARTMENT OF TRANSPORTATION**

**PAVEMENT MARKING PLAN  
HARNETT AND JOHNSTON COUNTIES**

**LOCATION: I-95 FROM NORTH OF HODGES CHAPEL ROAD  
(EXIT 77) TO I-40 (EXIT 81).**

<small>TIP NO.</small> I - 5986B	<small>SHEET NO.</small> PMP - 1
<small>APPROVED</small> <i>William J. Hamilton</i> <small>AC050070468484</small>	
<small>DATE:</small> 3/15/2021	
	
<small>DOCUMENT NOT CONSIDERED FINAL UNLESS ALL SIGNATURES COMPLETED</small>	

**ROADWAY STANDARD DRAWING**

THE FOLLOWING ROADWAY STANDARDS AS APPEAR IN "ROADWAY STANDARD DRAWINGS" - PROJECT SERVICES UNIT - N.C. DEPARTMENT OF TRANSPORTATION - RALEIGH, N.C., DATED JANUARY 2018 ARE APPLICABLE TO THIS PROJECT AND BY REFERENCE HEREBY ARE CONSIDERED A PART OF THESE PLANS:

<u>STD. NO.</u>	<u>TITLE</u>
1205.01	PAVEMENT MARKINGS - LINE TYPES AND OFFSETS
1205.02	PAVEMENT MARKINGS - TWO-LANE AND MULTILANE ROADWAYS
1205.03	PAVEMENT MARKINGS - EXIT AND ENTRANCE RAMP
1205.04	PAVEMENT MARKINGS - INTERSECTIONS
1205.05	PAVEMENT MARKINGS - TURN LANES
1205.06	PAVEMENT MARKINGS - LANE DROPS
1205.07	PAVEMENT MARKINGS - PEDESTRIAN CROSSWALKS
1205.08	PAVEMENT MARKINGS - SYMBOLS AND WORD MESSAGES
1205.09	PAVEMENT MARKINGS - PAINTED ISLANDS
1205.12	PAVEMENT MARKINGS - BRIDGES
1205.13	PAVEMENT MARKINGS - LANE REDUCTIONS
1205.14	PAVEMENT MARKINGS - ROUNDABOUTS
1250.01	RAISED PAVEMENT MARKERS - INSTALLATION SPACING
1251.01	RAISED PAVEMENT MARKERS - PERMANENT AND TEMPORARY
1253.01	RAISED PAVEMENT MARKERS - SNOWPLOWABLE
1261.01	GUARDRAIL AND BARRIER DELINEATORS - INSTALLATION SPACING
1261.02	GUARDRAIL AND BARRIER DELINEATORS - TYPES AND MOUNTING
1262.01	GUARDRAIL END DELINEATION
1264.01	OBJECT MARKERS - TYPES
1264.02	OBJECT MARKERS - INSTALLATION
1267.01	FLEXIBLE DELINEATORS - INSTALLATION
1267.02	FLEXIBLE DELINEATORS - SPACING TABLES
1267.03	FLEXIBLE DELINEATORS - INTERCHANGE PLACEMENT

**GENERAL NOTES**

THE FOLLOWING GENERAL NOTES APPLY AT ALL TIMES FOR THE DURATION OF THE CONSTRUCTION PROJECT, EXCEPT WHEN OTHERWISE NOTED IN THE PLAN, OR DIRECTED BY THE ENGINEER.

- A) INSTALL PAVEMENT MARKINGS AND PAVEMENT MARKERS ON THE FINAL SURFACE AS FOLLOWS:
 

<u>ROAD NAME</u>	<u>MARKING</u>	<u>MARKER</u>
I-95	THERMOPLASTIC	SNOWPLOWABLE
Y-LINES	THERMOPLASTIC	RAISED
BRIDGES	POLYUREA	SNOWPLOWABLE
- B) TIE PROPOSED PAVEMENT MARKING LINES TO EXISTING PAVEMENT MARKING LINES.
- C) REMOVE/REPLACE ANY CONFLICTING/DAMAGED PAVEMENT MARKINGS AND MARKERS.
- D) STOP BAR LOCATION AT NON-SIGNALIZED INTERSECTIONS MAY BE ADJUSTED AS DIRECTED BY THE ENGINEER.
- E) REFER TO APPROVED SIGNAL PLANS FOR STOP BAR LOCATIONS AT SIGNALIZED INTERSECTIONS.

**PLANS PREPARED BY: Ramey Kemp Associates**

**W. JASON HAMILTON, P.E., PTOE** PROJECT MANAGER  
**TIMOTHY S. POPELKA, P.E.** PROJECT ENGINEER





**PAVEMENT MARKING SCHEDULE**

<u>SYMBOL</u>	<u>DESCRIPTION</u>
COLD APPLIED PLASTIC PAVEMENT MARKING SYMBOLS (90 MILS)	
C70	LEFT TURN ARROW
THERMOPLASTIC (4", 90 MILS)	
T1	WHITE EDGELINE
T2	WHITE SOLID LANE LINE
T4	3 FT. - 9 FT./SP WHITE MINISKIP
T5	2 FT. - 6 FT./SP WHITE MINISKIP
T10	YELLOW EDGELINE
T11	YELLOW SINGLE CENTER
T12	10 FT. YELLOW SKIP
T13	YELLOW DOUBLE CENTER
THERMOPLASTIC (6", 90 MILS)	
T20	WHITE EDGELINE
T21	WHITE SOLID LANE LINE
T22	10 FT. WHITE SKIP
T23	3 FT. - 9 FT./SP WHITE MINISKIP
T30	YELLOW EDGELINE
THERMOPLASTIC (8", 90 MILS)	
T40	WHITE GORELINE
T46	WHITE CROSSWALK LINE
THERMOPLASTIC (12", 90 MILS)	
T50	WHITE GORELINE
T54	3 FT. - 9 FT./SP WHITE MINISKIP
T55	3 FT. - 3 FT./SP WHITE MINISKIP
THERMOPLASTIC (24", 90 MILS)	
T61	WHITE STOPBAR
T62	WHITE CROSSWALK LINE
THERMOPLASTIC PAVEMENT MARKING SYMBOLS (90 MILS)	
T70	LEFT TURN ARROW
T71	RIGHT TURN ARROW
T72	STRAIGHT ARROW
T79	MERGE ARROW
T80	RAMP ARROW
T100	ALPHANUMERIC CHAR.
T103	24" YIELD LINE TRIANGLE
POLYUREA (4")	
V1	WHITE EDGELINE
V4	3 FT. - 9 FT./SP WHITE MINISKIP
V13	YELLOW DOUBLE CENTER
POLYUREA (6")	
V20	WHITE EDGELINE
V22	10 FT. WHITE SKIP
V30	YELLOW EDGELINE
POLYUREA (12")	
V54	3 FT. - 9 FT./SP WHITE MINISKIP

**INDEX**

<u>SHEET NO.</u>	<u>DESCRIPTION</u>
PMP - 1	PAVEMENT MARKING PLAN COVER SHEET AND PAVEMENT MARKING SCHEDULE
PMP-34-47	PAVEMENT MARKING DETAILS
PMP-66-69	PAVEMENT MARKING DETAILS

TIP NO. I - 5986B	SHEET NO. PMP - 34
APPROVED: <i>William J. Hamilton</i> <small>AS06070488884</small>	
DATE: 3/15/2021	
SEAL 	
DOCUMENT NOT CONSIDERED FINAL UNLESS ALL SIGNATURES COMPLETED	
 <b>RKA</b> RAMEY KEMP ASSOCIATES <small>5808 Faringdon Place Raleigh, North Carolina 27609 Phone: 919-872-5115</small>	

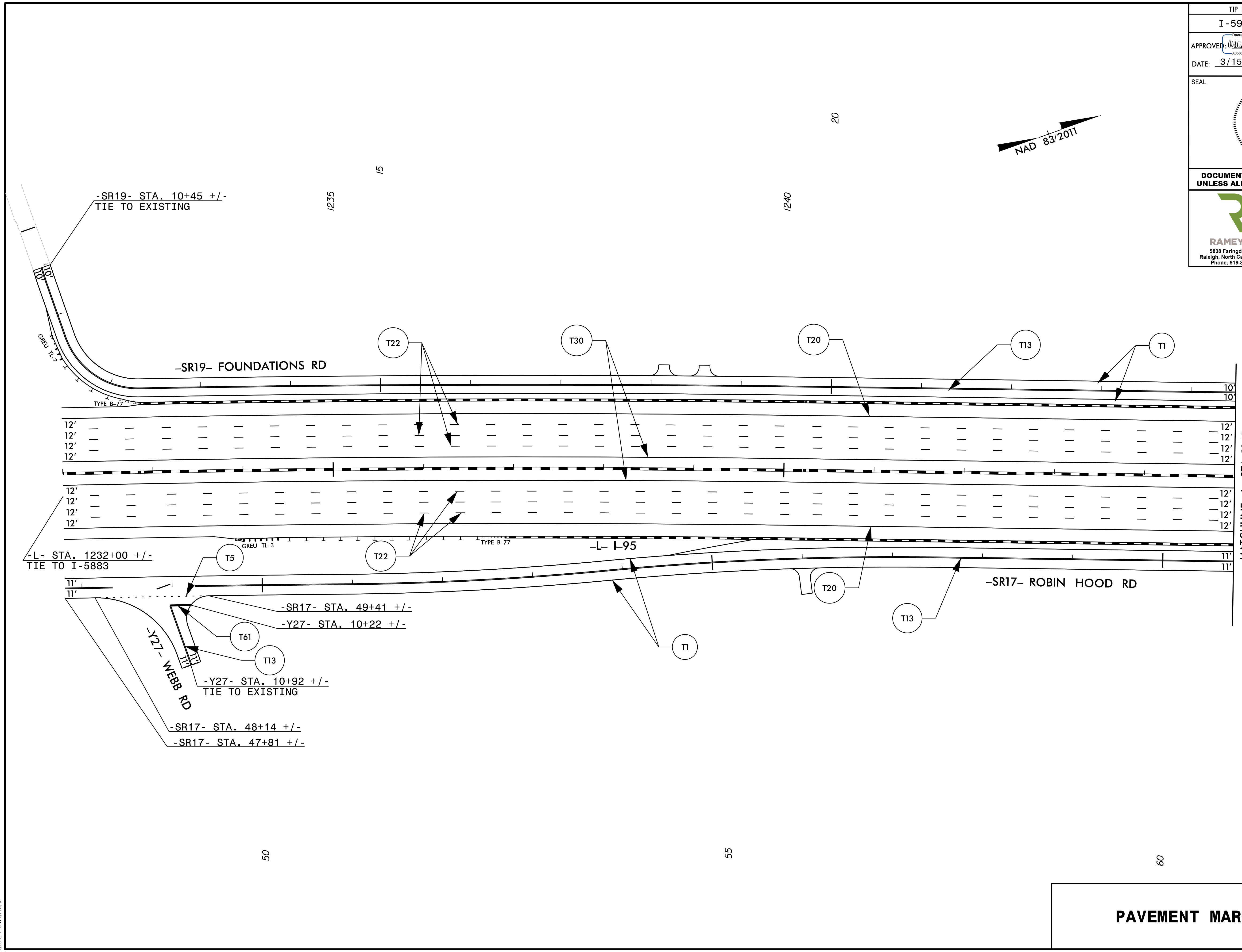



3/15/2021 11:59:56 AM I:\pmp-34.dgn User: Jwendt

50

55

60

# PAVEMENT MARKINGS

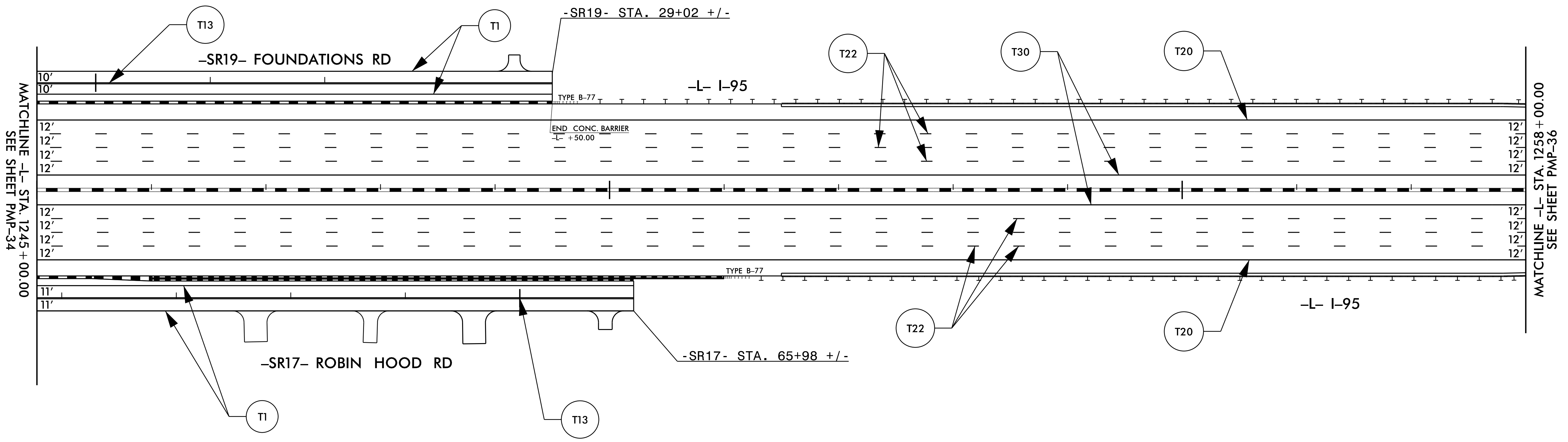

TIP NO. I - 5986B	SHEET NO. PMP - 35
APPROVED: <i>William J. Hamilton</i> <small>AS25007468454</small>	
DATE: 3/15/2021	
SEAL 	
DOCUMENT NOT CONSIDERED FINAL UNLESS ALL SIGNATURES COMPLETED	
 <b>RAMEY KEMP ASSOCIATES</b> <small>5808 Faringdon Place Raleigh, North Carolina 27609 Phone: 919-872-5115</small>	



3/15/2021  
I:\15986B\1C\_pmp-35.dgn  
User: J.Wendt

# PAVEMENT MARKINGS



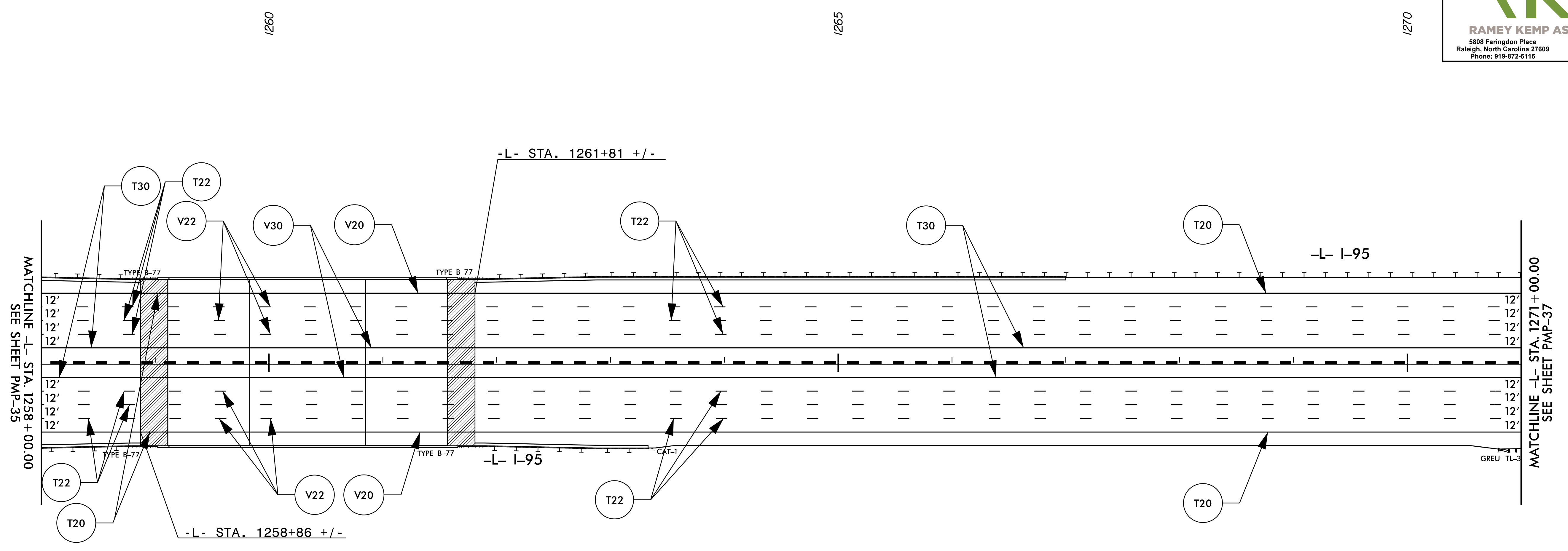

TIP NO. I - 5986B	SHEET NO. PMP - 36
APPROVED: <i>William J. Hamilton</i> <small>AC090070468484</small>	
DATE: 3/15/2021	
SEAL 	
DOCUMENT NOT CONSIDERED FINAL UNLESS ALL SIGNATURES COMPLETED	
 <b>RKA</b> RAMEY KEMP ASSOCIATES <small>5808 Faringdon Place Raleigh, North Carolina 27609 Phone: 919-872-5115</small>	



3/15/2021  
I:\15986B\1C\_pmp-36.dgn  
User: Jwendt

# PAVEMENT MARKINGS

TIP NO. I - 5986B	SHEET NO. PMP - 37
APPROVED: <i>William J. Hamilton</i> <small>AD5900704848484</small>	
DATE: 3/15/2021	
SEAL 	
DOCUMENT NOT CONSIDERED FINAL UNLESS ALL SIGNATURES COMPLETED	
 <b>RAMEY KEMP ASSOCIATES</b> <small>5808 Faringdon Place Raleigh, North Carolina 27609 Phone: 919-872-5115</small>	



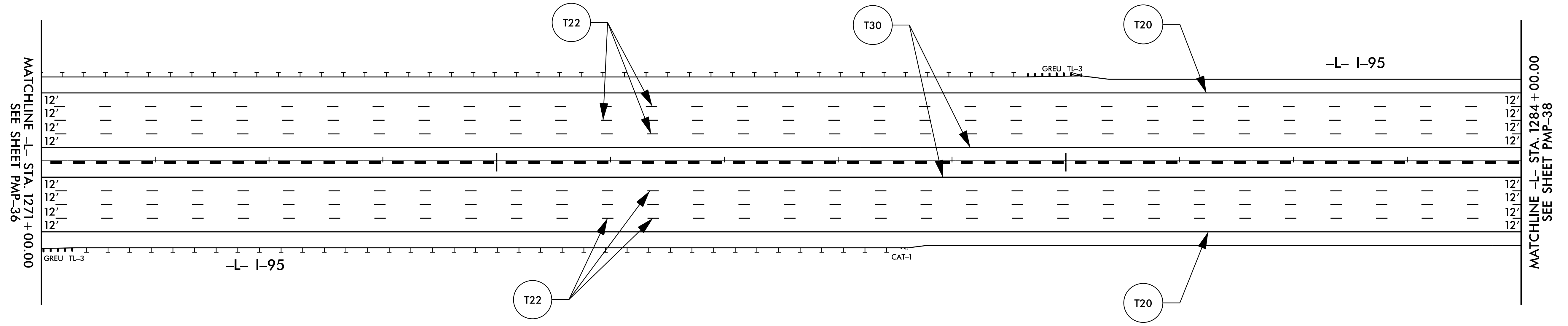

1275

1280



3/15/2021 11:15:58 AM I:\15986B\1C\_pmp-37.dgn User: J.Wendt

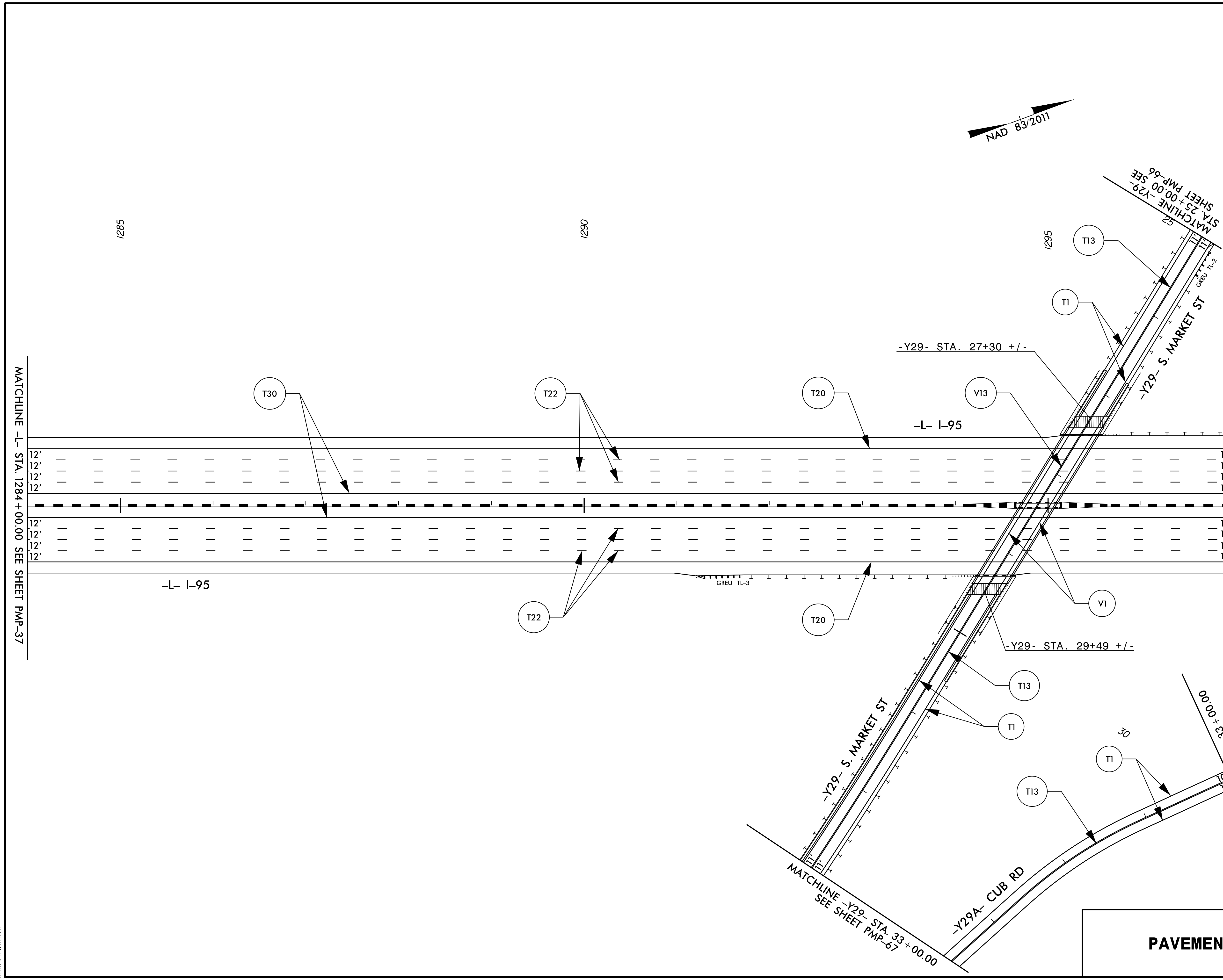

**PAVEMENT MARKINGS**

TIP NO. I - 5986B	SHEET NO. PMP - 38
APPROVED: <i>William J. Hamilton</i> AS050770464884	
DATE: 3/15/2021	
SEAL 	
DOCUMENT NOT CONSIDERED FINAL UNLESS ALL SIGNATURES COMPLETED	
 <b>RKA</b> RAMEY KEMP ASSOCIATES 5808 Faringdon Place Raleigh, North Carolina 27609 Phone: 919-872-5115 NC License No. C-0910 www.rameykemp.com	



**PAVEMENT MARKINGS**

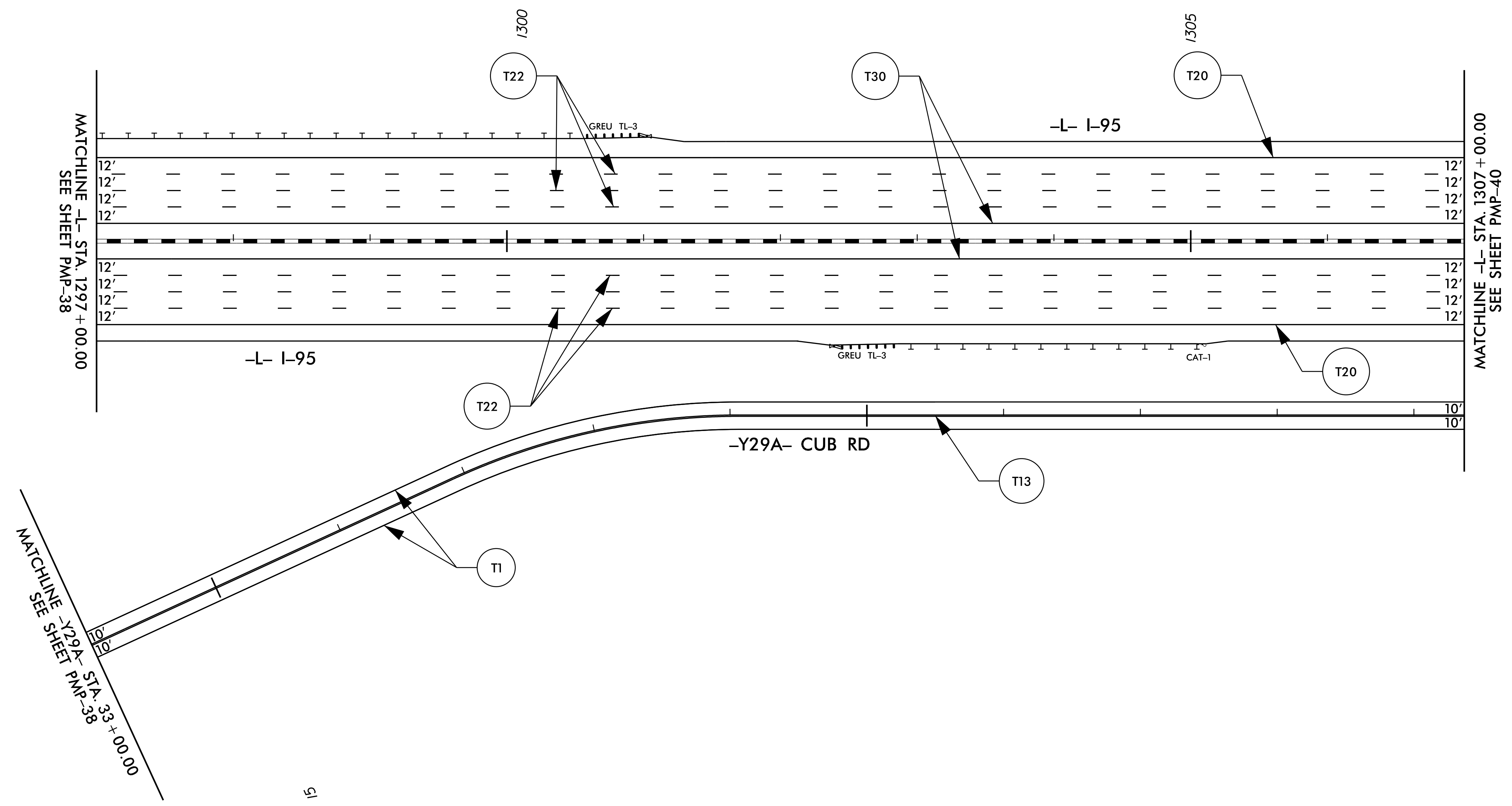

3/15/2021  
 I:\15986B\1C\_pmp-38.dgn  
 User: JWendt

TIP NO. I - 5986B	SHEET NO. PMP - 39
APPROVED: <i>William J. Hamilton</i> <small>AS0007704648484</small>	
DATE: 3/15/2021	
SEAL 	
DOCUMENT NOT CONSIDERED FINAL UNLESS ALL SIGNATURES COMPLETED	
 <b>RAMEY KEMP ASSOCIATES</b> <small>5808 Faringdon Place Raleigh, North Carolina 27609 Phone: 919-872-5115</small> <small>NC License No. C-0910 www.rameykemp.com</small>	



3/15/2021  
I:\15986B\1C\_pmp-39.dgn  
User: JWend

**PAVEMENT MARKINGS**

TIP NO. I - 5986B	SHEET NO. PMP - 40
APPROVED: <i>William J. Hamilton</i> <small>AD560070488484</small>	
DATE: 3/15/2021	
SEAL 	
<b>DOCUMENT NOT CONSIDERED FINAL UNLESS ALL SIGNATURES COMPLETED</b>	
 <b>RAMEY KEMP ASSOCIATES</b> <small>5808 Faringdon Place Raleigh, North Carolina 27609 Phone: 919-872-5115</small> <small>NC License No. C-0910 www.rameykemp.com</small>	

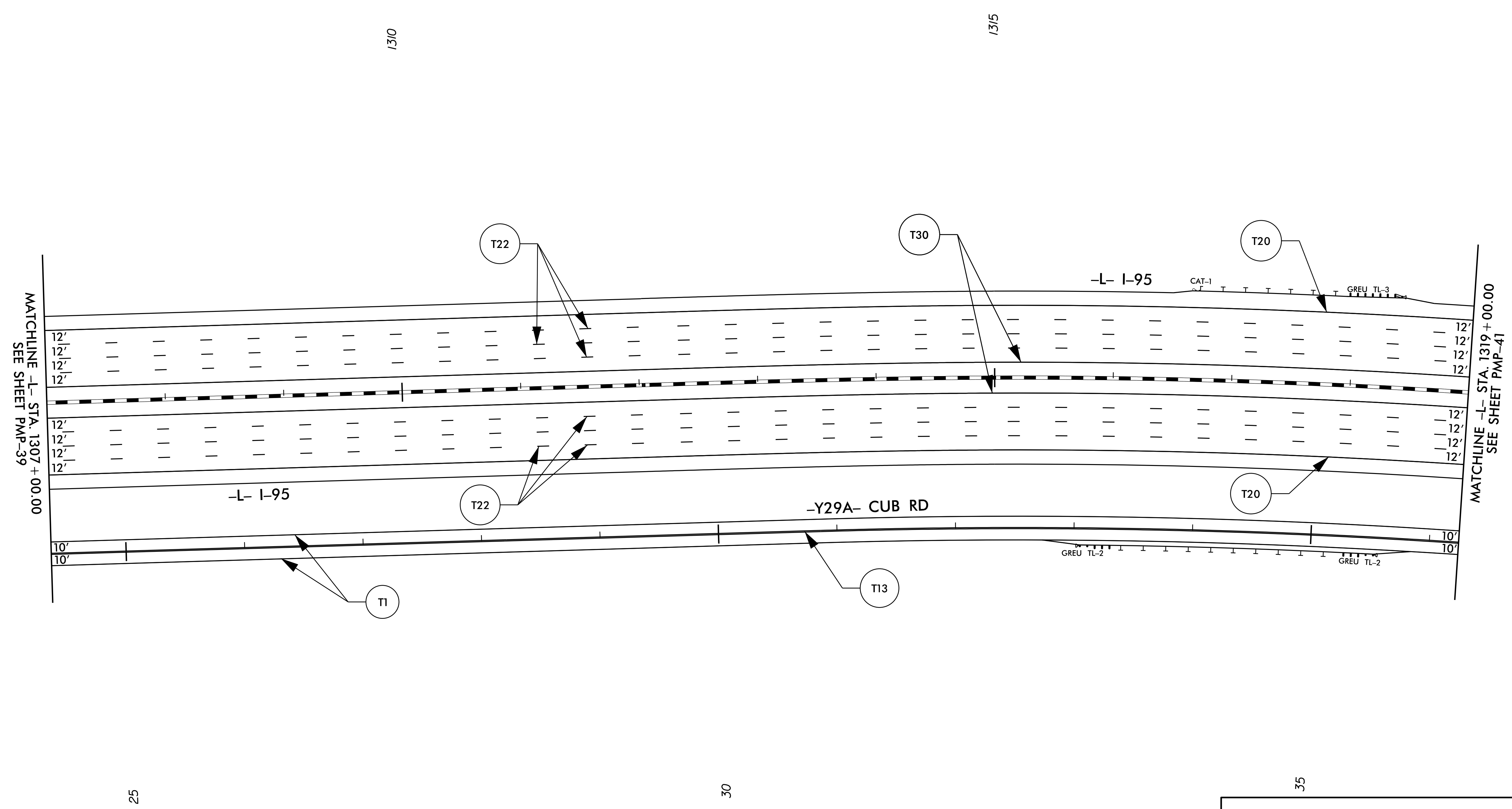

3/15/2021  
I:\5986B\1C\_pmp-40.dgn  
User: Jwendt



25

30

35

**PAVEMENT MARKINGS**



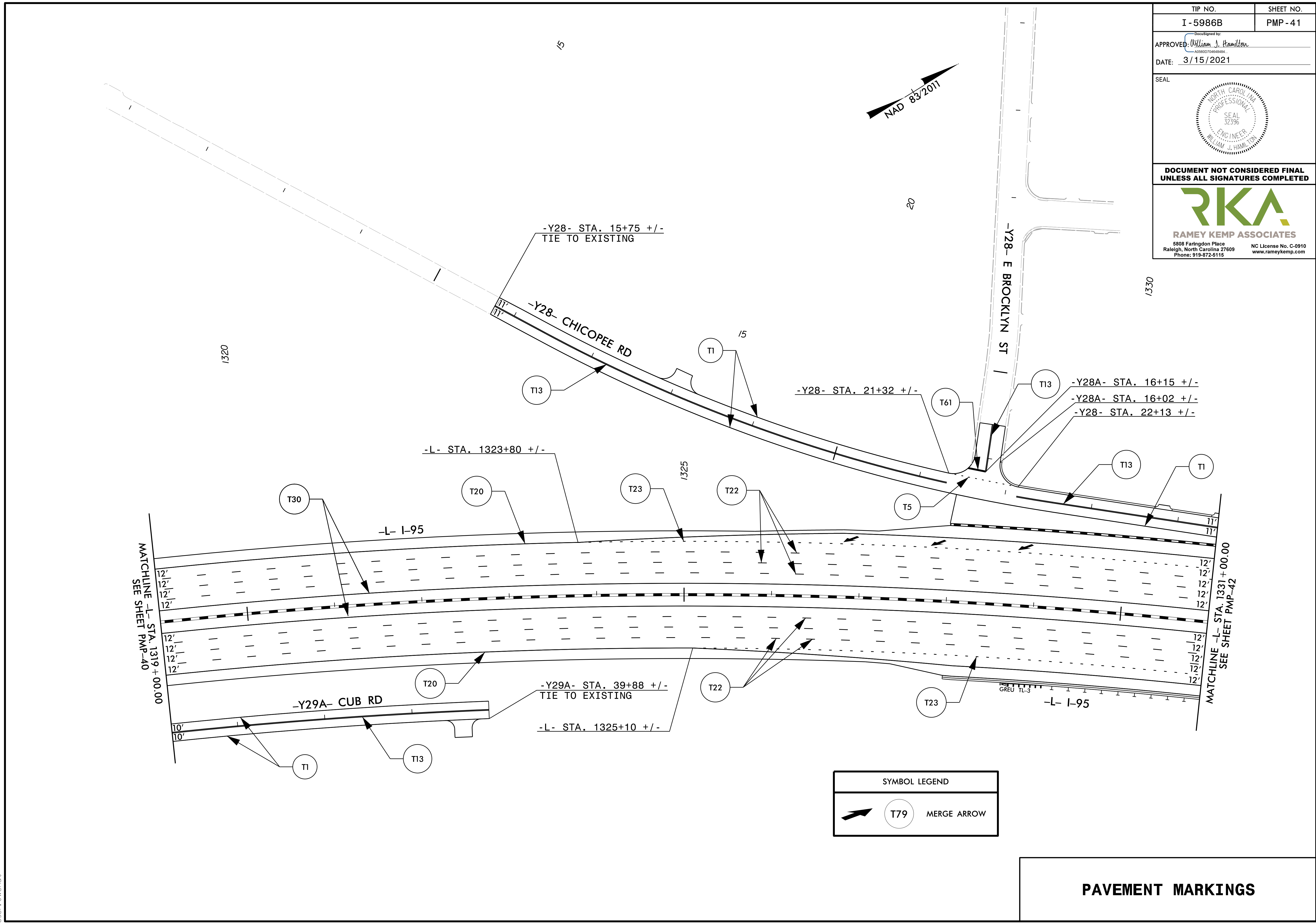

TIP NO. I-5986B	SHEET NO. PMP-41
APPROVED: <i>William J. Hamilton</i> -ASSET0704848484-	
DATE: 3/15/2021	
SEAL 	
DOCUMENT NOT CONSIDERED FINAL UNLESS ALL SIGNATURES COMPLETED	
 <b>RKA</b> RAMEY KEMP ASSOCIATES 5808 Faringdon Place Raleigh, North Carolina 27609 Phone: 919-872-5115 NC License No. C-0910 www.rameykemp.com	



SYMBOL LEGEND	
	T79 MERGE ARROW

**PAVEMENT MARKINGS**

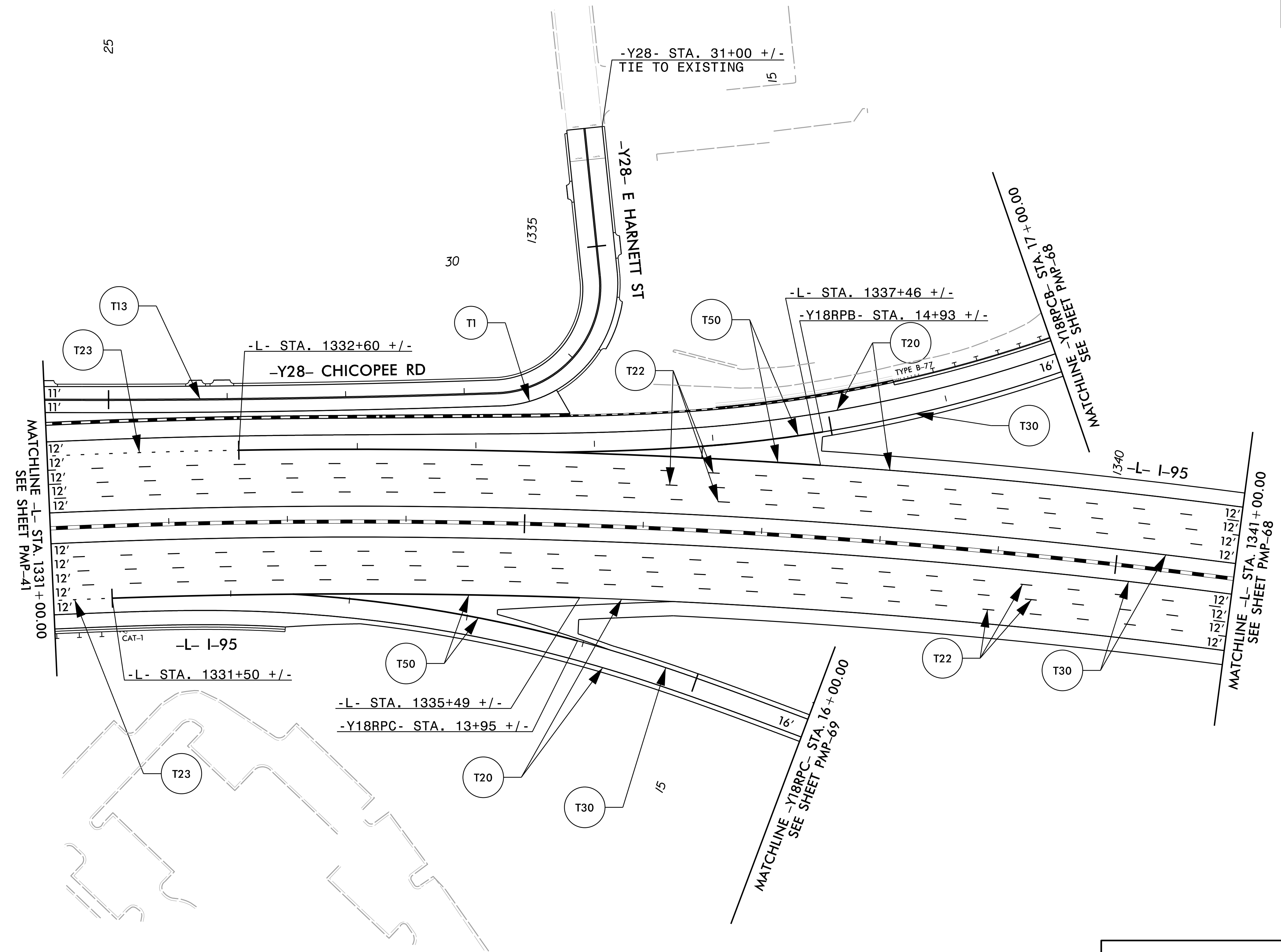

3/15/2021  
 I:\15986B\1C\_pmp-41.dgn  
 User: Jwendt

TIP NO. I - 5986B	SHEET NO. PMP - 42
Approved by: <u>William J. Hamilton</u> <small>A0560070468484</small>	
DATE: 3/15/2021	
SEAL 	
DOCUMENT NOT CONSIDERED FINAL UNLESS ALL SIGNATURES COMPLETED	
 <b>RAMEY KEMP ASSOCIATES</b> <small>5808 Faringdon Place Raleigh, North Carolina 27609 Phone: 919-872-5115</small> <small>NC License No. C-0910 www.rameykemp.com</small>	



3/15/2021  
 I:\15986B\_1C\_pmp-42.dgn  
 User: Jwendt

**PAVEMENT MARKINGS**

TIP NO. I - 5986B	SHEET NO. PMP - 42A
APPROVED: <i>William J. Hamilton</i> <small>ADDRESS: 704648484</small>	
DATE: 3/15/2021	
SEAL 	
DOCUMENT NOT CONSIDERED FINAL UNLESS ALL SIGNATURES COMPLETED	
 <b>RKA</b> RAMEY KEMP ASSOCIATES <small>5808 Faringdon Place Raleigh, North Carolina 27609 Phone: 919-872-5115</small>	

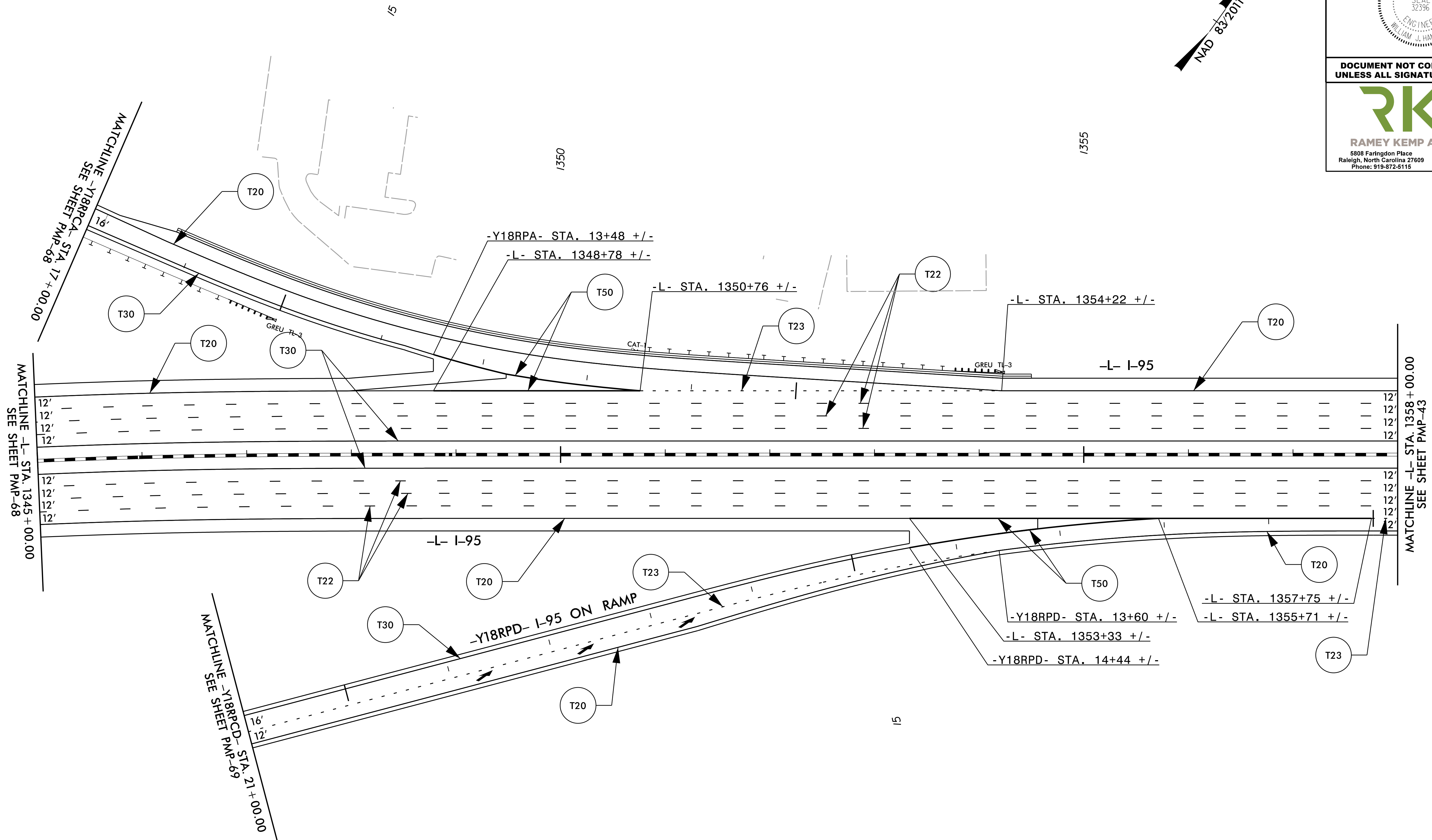
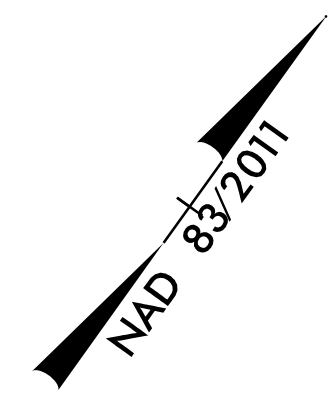



SYMBOL LEGEND	
	T79 MERGE ARROW



**PAVEMENT MARKINGS**

3/15/2021 11:15:58 AM User: Jwendt

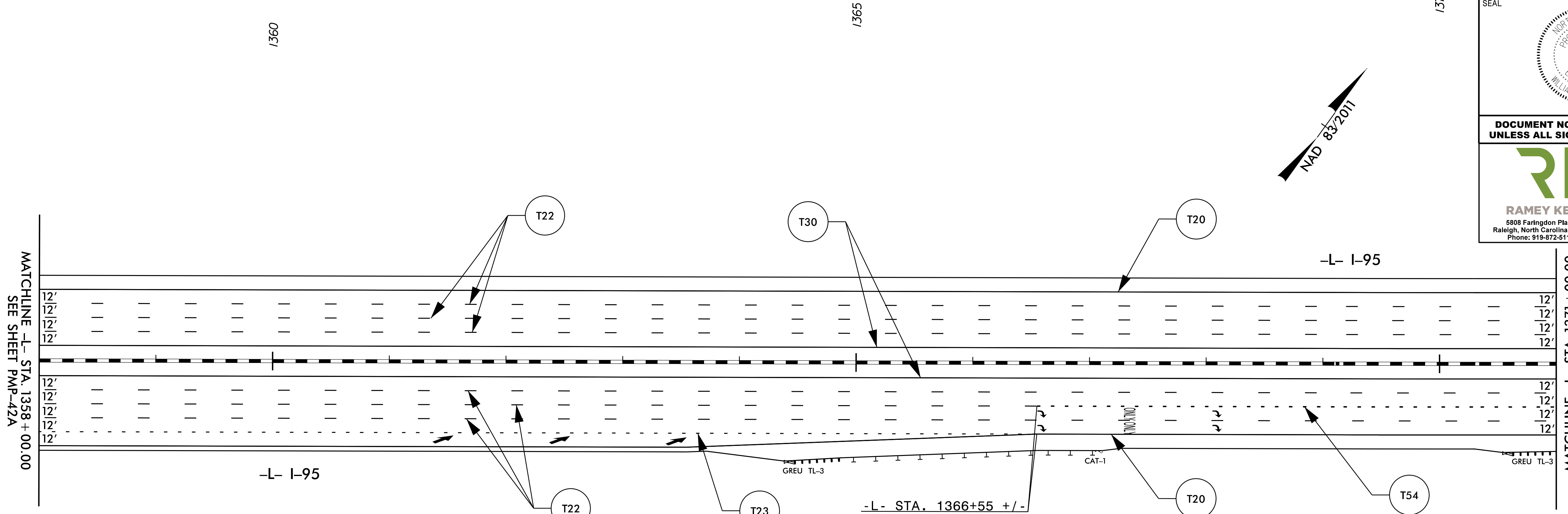

TIP NO. I - 5986B	SHEET NO. PMP - 43
APPROVED: <i>William J. Hamilton</i> <small>DESIGNED BY: WJH LICENSED PROFESSIONAL ENGINEER ASSET NUMBER: 455607846484</small>	
DATE: 3/15/2021	
SEAL 	
DOCUMENT NOT CONSIDERED FINAL UNLESS ALL SIGNATURES COMPLETED	
 <b>RKA</b> RAMEY KEMP ASSOCIATES <small>5808 Faringdon Place Raleigh, North Carolina 27609 Phone: 919-872-5115</small>	
<small>NC License No. C-0910 www.rameykemp.com</small>	

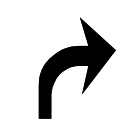



SYMBOL LEGEND		
	T71	RIGHT ARROW
	T79	MERGE ARROW
ONLY	T100	ALPHANUMERIC CHAR.

-Y33- STA. 10+50 +/-  
TIE TO EXISTING

**PAVEMENT MARKINGS**

3/15/2021  
I:\15986B\1C\_pmp-43.dgn  
User: J.Wendt



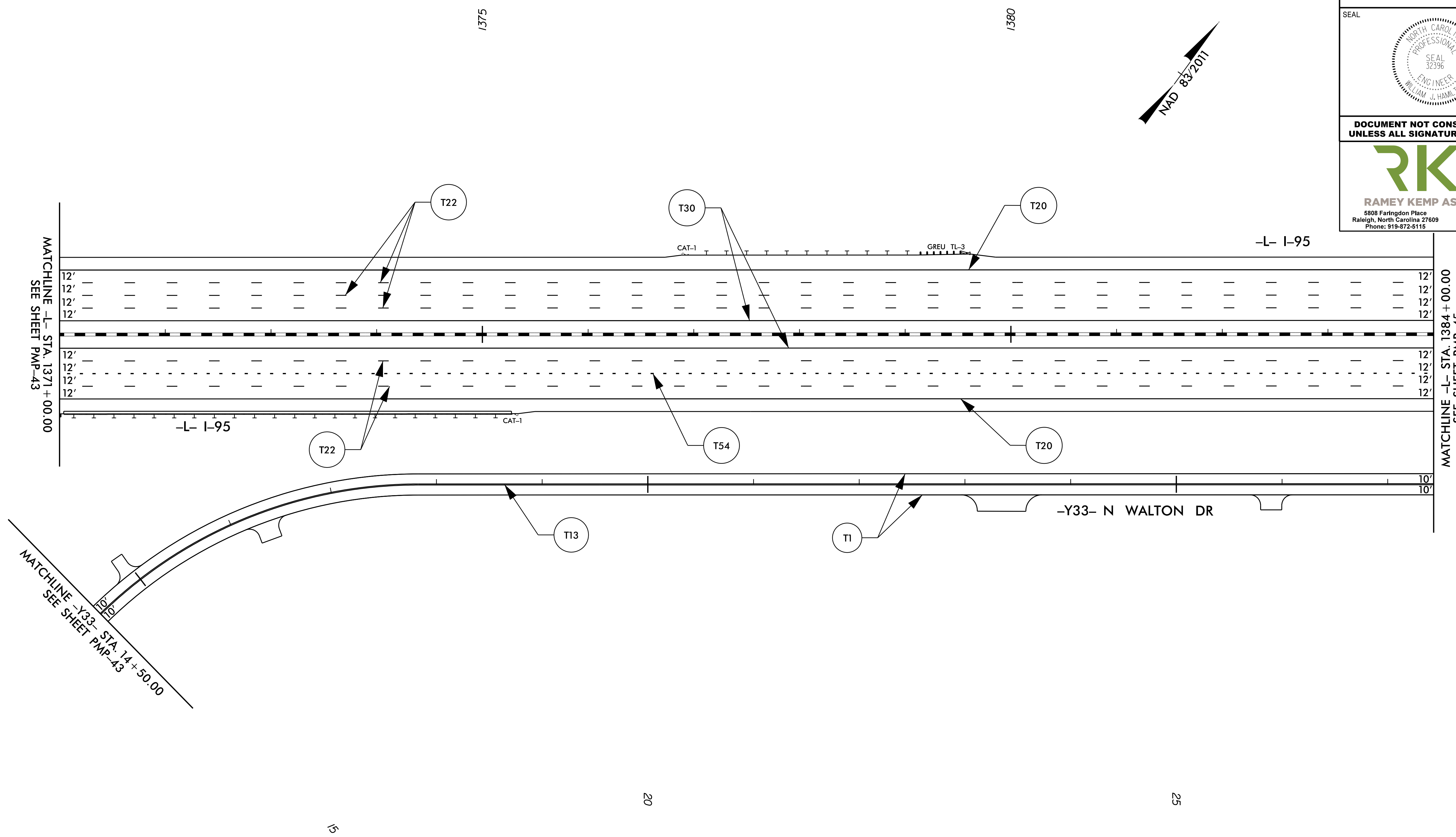

TIP NO. I - 5986B	SHEET NO. PMP - 44
APPROVED: <i>William J. Hamilton</i> <small>AS0600704848484...</small>	
DATE: 3/15/2021	
SEAL 	
DOCUMENT NOT CONSIDERED FINAL UNLESS ALL SIGNATURES COMPLETED	
 <b>RKA</b> RAMEY KEMP ASSOCIATES <small>5808 Faringdon Place Raleigh, North Carolina 27609 Phone: 919-872-5115</small>	





3/15/2021  
 I:\15986B\1C\_pmp-44.dgn  
 User: J.Wendt

**PAVEMENT MARKINGS**

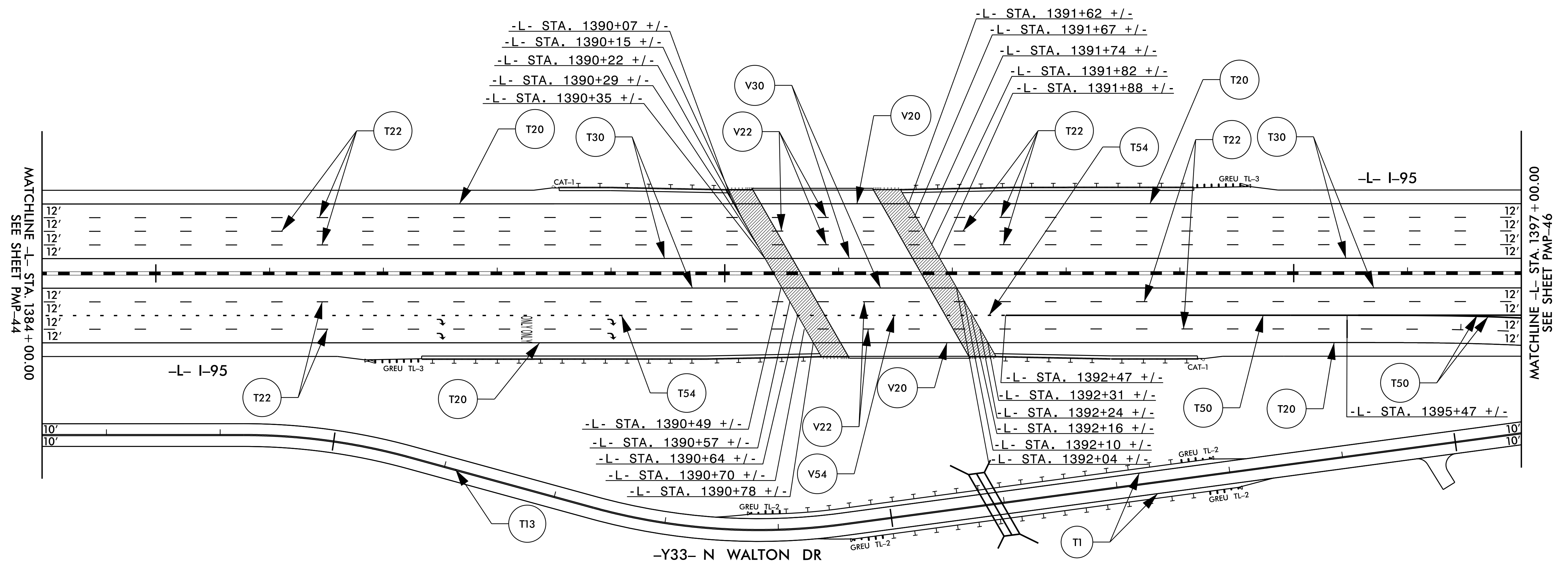
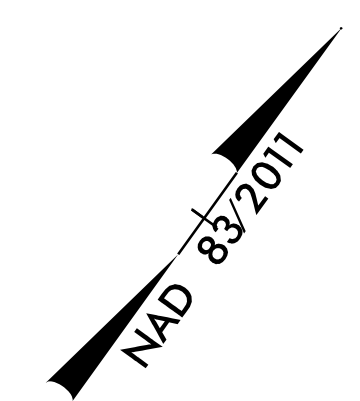

TIP NO. I - 5986B	SHEET NO. PMP - 45
APPROVED: <i>William J. Hamilton</i> AS000704648484	
DATE: 3/15/2021	
SEAL 	
DOCUMENT NOT CONSIDERED FINAL UNLESS ALL SIGNATURES COMPLETED	
 <b>RAMEY KEMP ASSOCIATES</b> 5808 Faringdon Place Raleigh, North Carolina 27609 Phone: 919-872-5115 NC License No. C-0910 www.rameykemp.com	



SYMBOL LEGEND	
	T71 RIGHT ARROW
	T100 ALPHANUMERIC CHAR.

**PAVEMENT MARKINGS**

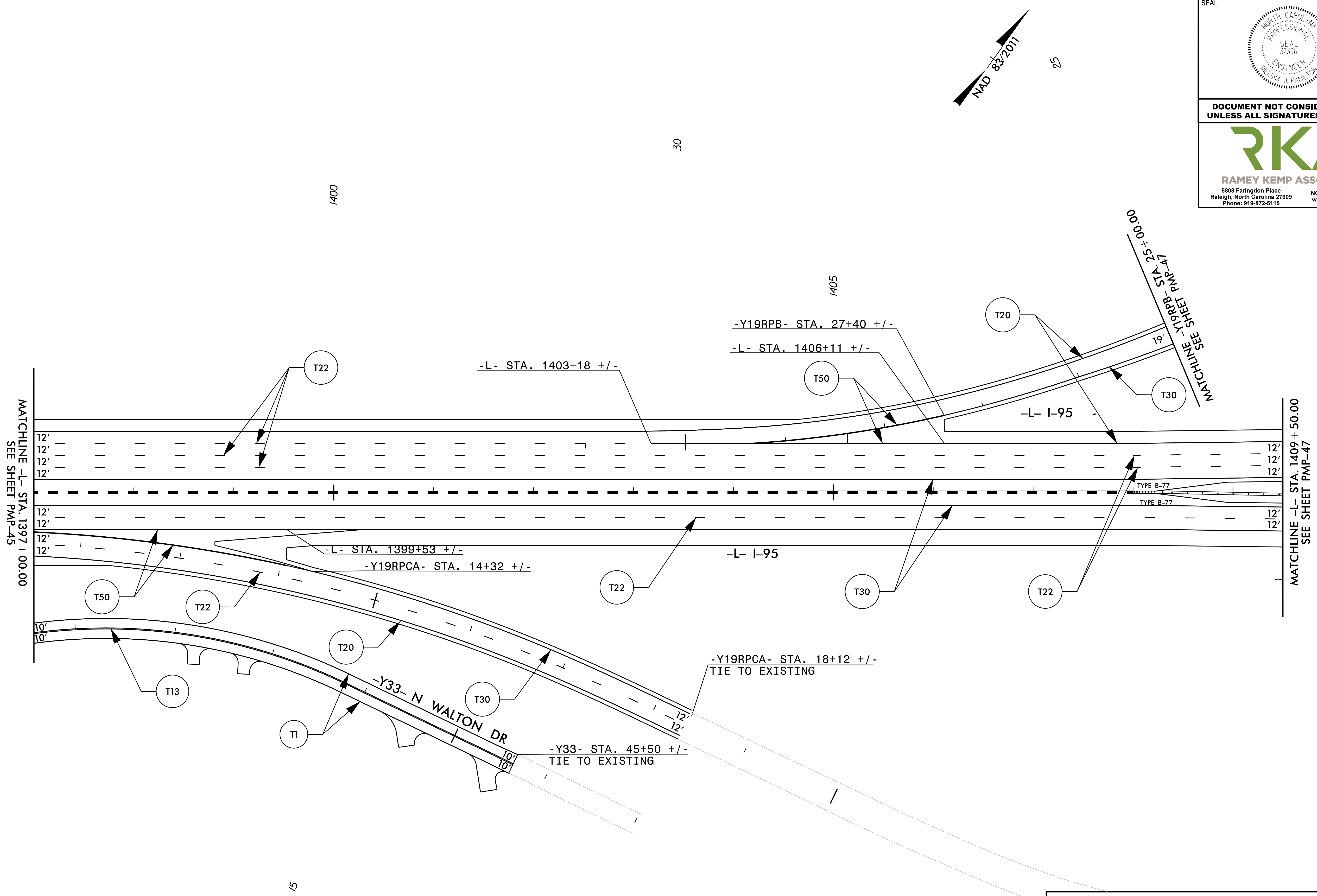

3/15/2021 11:15:58 AM I:\15986B\1C\_pmp-45.dgn User: Jwendt

TIP NO.	SHEET NO.
I - 5986B	PMP - 46
APPROVED: <i>William J. Hamilton</i> 3/15/2021	
DATE: 3/15/2021	
SEAL 	
DOCUMENT NOT CONSIDERED FINAL UNLESS ALL SIGNATURES COMPLETED	
 <b>RAMEY KEMP ASSOCIATES</b> 5808 Faringdon Place Raleigh, North Carolina 27609 Phone: 919-872-5115 NC License No. C-0910 www.rameykemp.com	



**PAVEMENT MARKINGS**

3/15/2021  
 I:\15986B\1C\_pmp-46.dgn  
 User: J.Wendt

TIP NO.	SHEET NO.
I - 5986B	PMP - 47
APPROVED: <i>William J. Hamilton</i> <small>ASSOCIATE ENGINEER</small>	
DATE: 3/15/2021	
SEAL	
	
DOCUMENT NOT CONSIDERED FINAL UNLESS ALL SIGNATURES COMPLETED	
	
<small>5808 Faringdon Place Raleigh, North Carolina 27609 Phone: 919-872-5115</small>	

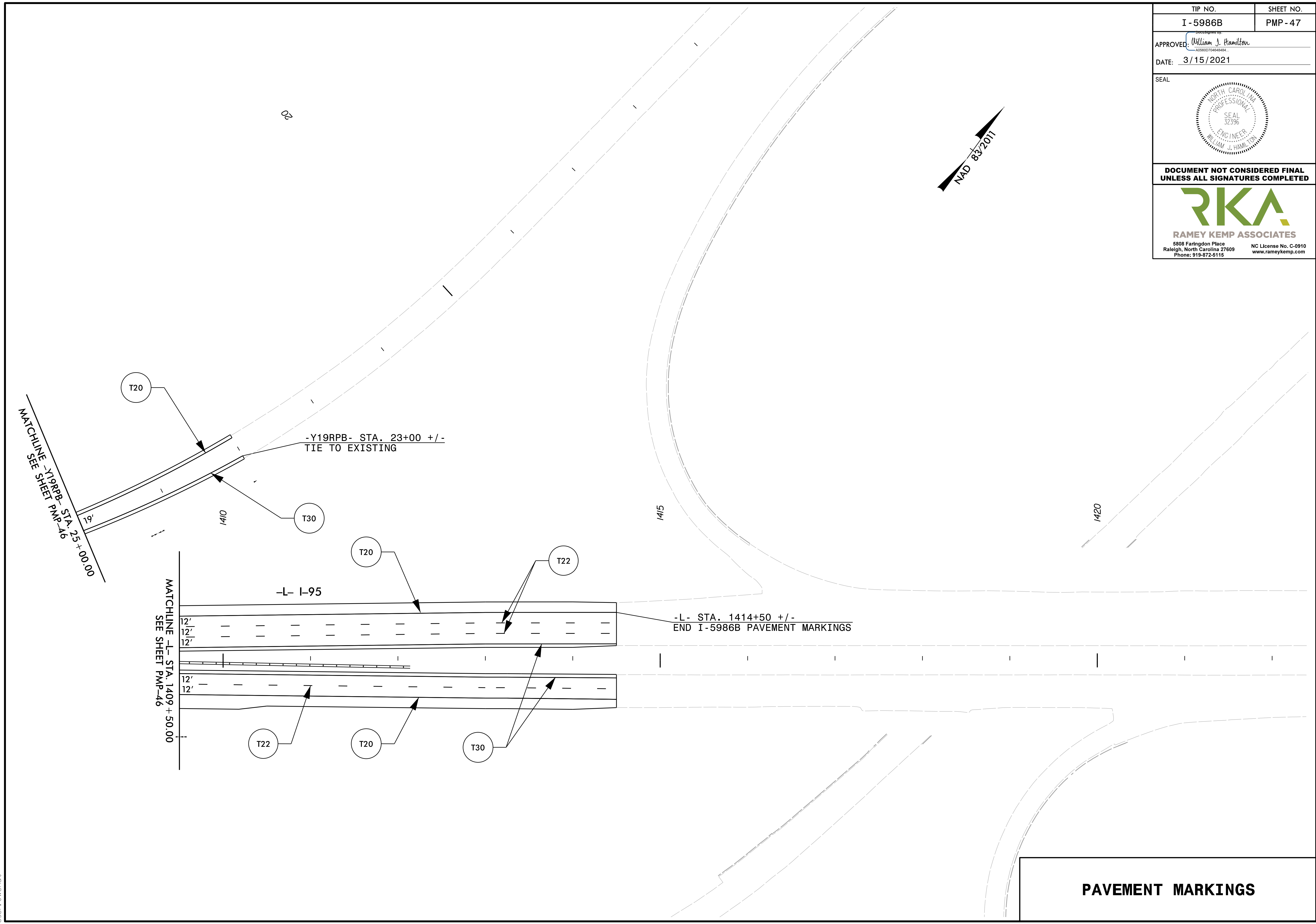
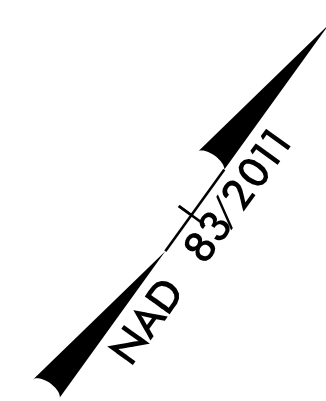

**PAVEMENT MARKINGS**

3/15/2021  
 I:\5986B\1C\_pmp-47.dgn  
 User: Jwendt



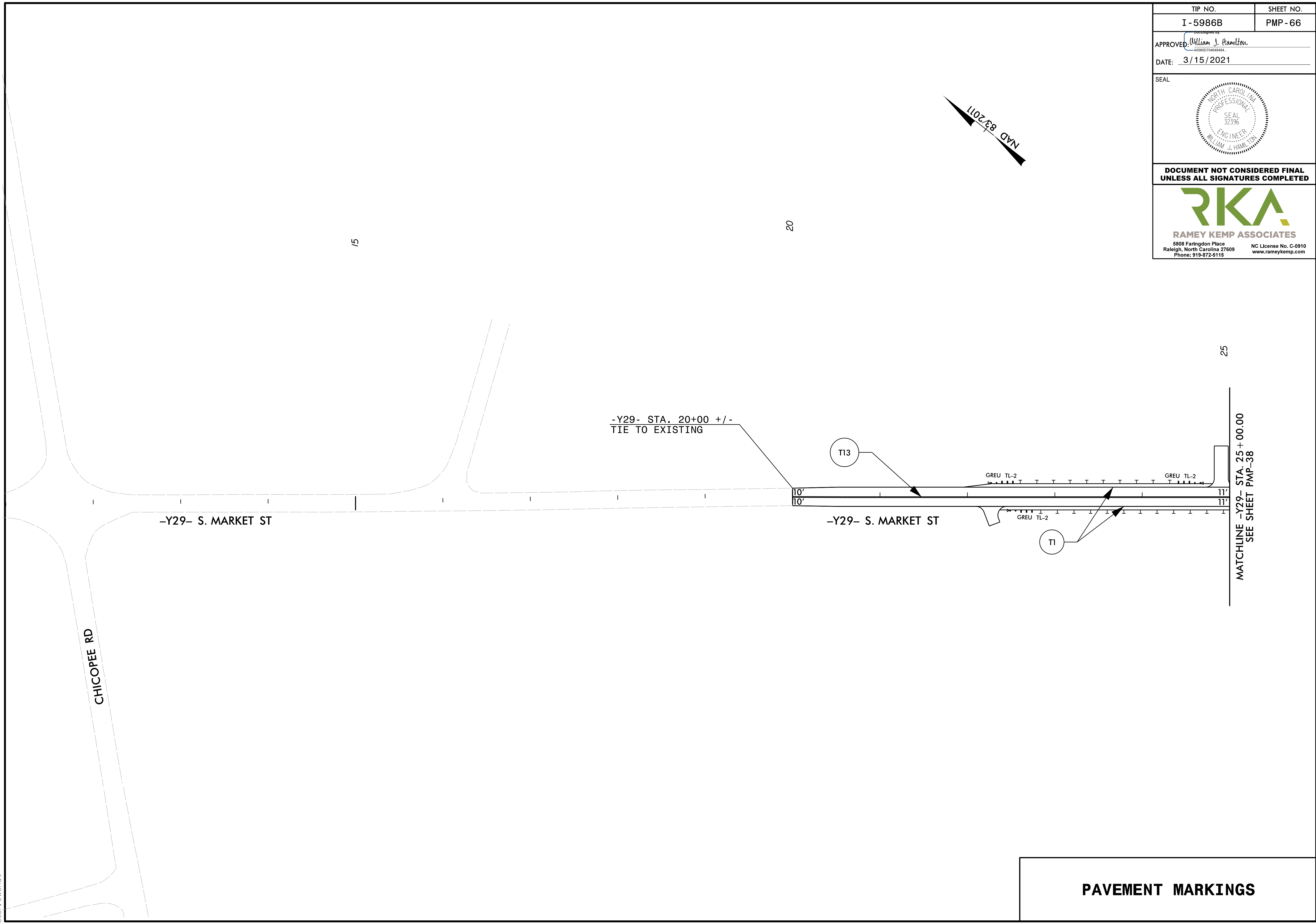

TIP NO.	SHEET NO.
I - 5986B	PMP - 66
APPROVED: <i>William J. Hamilton</i> <small>AS00070648864</small>	
DATE: 3/15/2021	
SEAL	
<p><b>DOCUMENT NOT CONSIDERED FINAL UNLESS ALL SIGNATURES COMPLETED</b></p>	
<p><b>RKA</b>  <b>RAMEY KEMP ASSOCIATES</b>  5808 Faringdon Place  Raleigh, North Carolina 27609  Phone: 919-872-5115  NC License No. C-0910  www.rameykemp.com</p>	



3/15/2021  
\\s15986b-1c-pmp-66.dgn  
User: JWendt

**PAVEMENT MARKINGS**

TIP NO. I - 5986B	SHEET NO. SIGN-67
APPROVED: <i>William J. Hamilton</i> <small>ASSOCIATE ENGINEER</small>	
DATE: 3/15/2021	
SEAL 	
DOCUMENT NOT CONSIDERED FINAL UNLESS ALL SIGNATURES COMPLETED	
 <b>RAMEY KEMP ASSOCIATES</b> <small>5808 Faringdon Place Raleigh, North Carolina 27609 Phone: 919-872-5115</small> <small>NC License No. C-0910 www.rameykemp.com</small>	

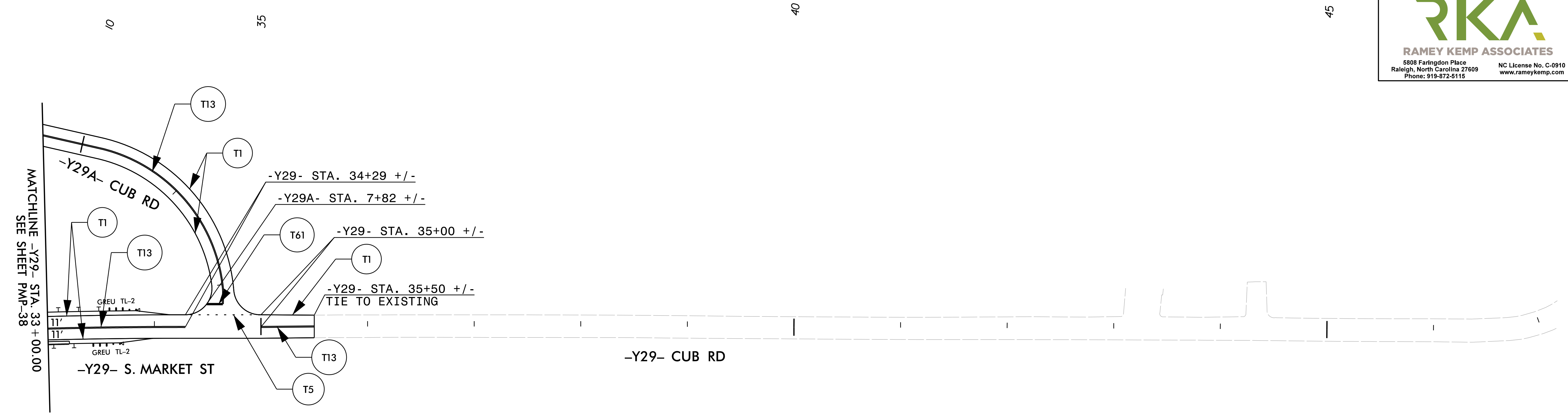

NAD 83/2011

10



35

40

45

3/15/2021  
I:\15986B\1C\_pmp-67.dgn  
User: JWendt

**PAVEMENT MARKINGS**

TIP NO. I - 5986B	SHEET NO. PMP - 68
APPROVED: <i>William J. Hamilton</i> ASPECT/70648484	
DATE: 3/15/2021	
SEAL 	
DOCUMENT NOT CONSIDERED FINAL UNLESS ALL SIGNATURES COMPLETED	
 <b>RKA</b> RAMEY KEMP ASSOCIATES 5808 Faringdon Place Raleigh, North Carolina 27609 Phone: 919-872-5115 NC License No. C-0910 www.rameykemp.com	

CURB RAMP LOCATIONS (CENTER OF RAMP AT FACE OF CURB)

1 -Y18- STA. 15+51.38, 41.25' RT	10 -Y18- STA. 19+90.69, 36.72' LT
2 -Y18- STA. 16+46.79, 40.87' RT	11 -Y18- STA. 21+70.70, 25.91' LT
3 -Y18- STA. 16+82.14, 40.79' RT	12 -Y18- STA. 21+82.62, 35.87' LT
4 -Y18- STA. 17+32.81, 36.31' RT	13 -Y18- STA. 22+24.11, 31.38' LT
5 -Y18- STA. 17+67.15, 34.48' RT	14 -Y18- STA. 22+46.02, 22.00' LT
6 -Y18- STA. 18+37.14, 35.57' RT	15 -Y18- STA. 21+72.20, 32.97' RT
7 -Y18- STA. 18+75.05, 40.77' RT	16 -Y18- STA. 22+04.66, 49.27' RT
8 -Y18- STA. 18+43.25, 42.83' LT	17 -Y18- STA. 22+44.42, 50.69' RT
9 -Y18- STA. 19+29.41, 46.74' LT	18 -Y18- STA. 22+49.36, 43.71' RT

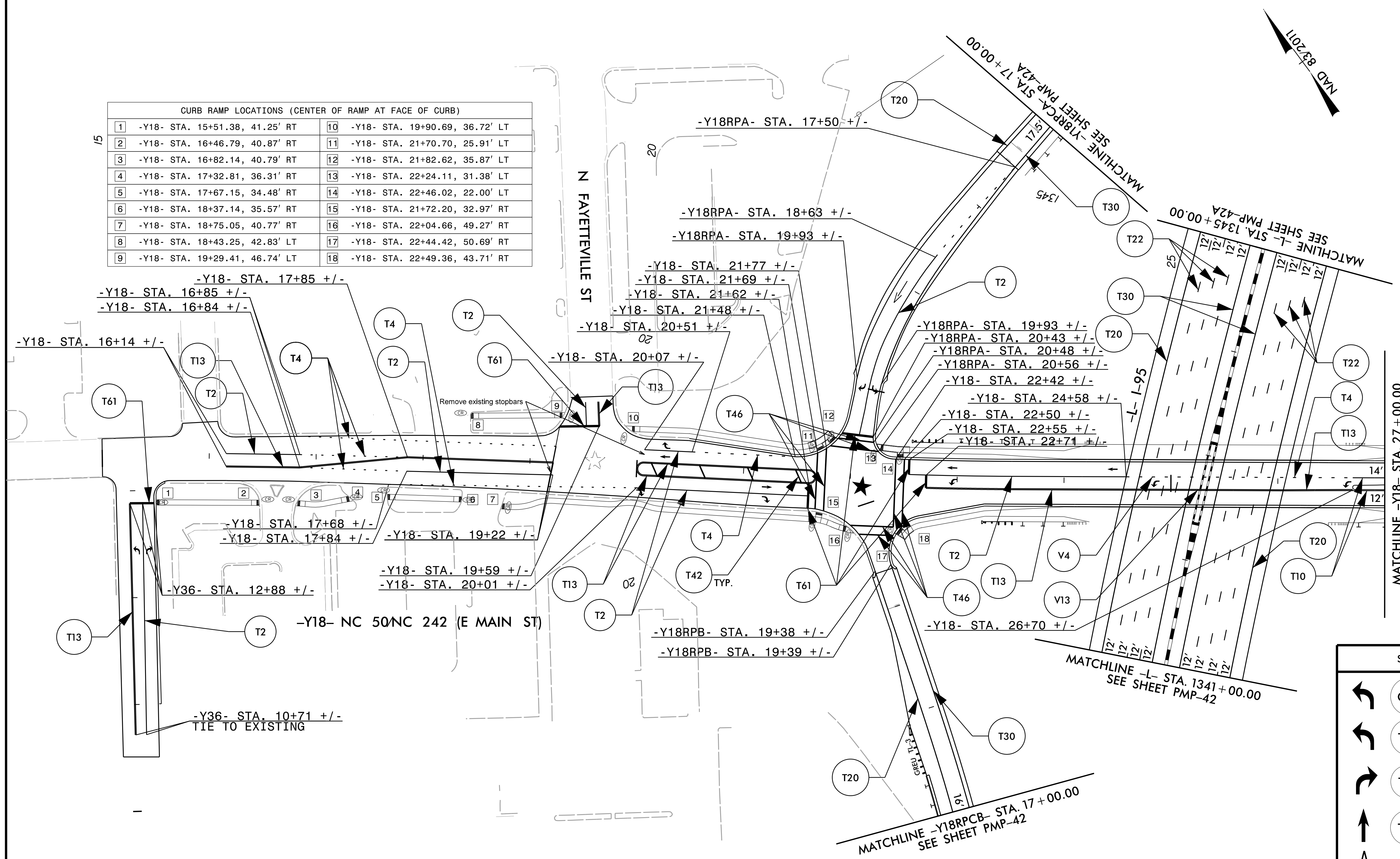

-Y18- STA. 17+85 +/-  
 -Y18- STA. 16+85 +/-  
 -Y18- STA. 16+84 +/-

-Y18- STA. 16+14 +/-

-Y18- STA. 17+68 +/-  
 -Y18- STA. 17+84 +/-  
 -Y18- STA. 19+22 +/-

-Y36- STA. 12+88 +/-

-Y18- NC 50NC 242 (E MAIN ST)

-Y36- STA. 10+71 +/-  
 TIE TO EXISTING

-Y18RPA- STA. 17+50 +/-

-Y18RPA- STA. 18+63 +/-

-Y18RPA- STA. 19+93 +/-

-Y18- STA. 21+77 +/-

-Y18- STA. 21+69 +/-

-Y18- STA. 21+62 +/-

-Y18- STA. 21+48 +/-

-Y18- STA. 20+51 +/-

-Y18- STA. 20+07 +/-

-Y18RPA- STA. 19+93 +/-

-Y18RPA- STA. 20+43 +/-

-Y18RPA- STA. 20+48 +/-

-Y18RPA- STA. 20+56 +/-

-Y18- STA. 22+42 +/-

-Y18- STA. 24+58 +/-

-Y18- STA. 22+50 +/-

-Y18- STA. 22+55 +/-

-Y18- STA. 22+71 +/-

-Y18RPA- STA. 19+38 +/-

-Y18RPA- STA. 19+39 +/-

-Y18- STA. 26+70 +/-

MATCHLINE -Y18- STA. 27+00.00  
 SEE SHEET PMP-69

MATCHLINE -L- STA. 1341+00.00  
 SEE SHEET PMP-42

MATCHLINE -Y18RPCB- STA. 17+00.00  
 SEE SHEET PMP-42

☆ SIGNAL TO BE REMOVED



★ SIGNALIZED INTERSECTION

SYMBOL LEGEND

	C70	LEFT ARROW
	T70	LEFT ARROW
	T71	RIGHT ARROW
	T72	STRAIGHT ARROW
	T80	RAMP ARROW

PAVEMENT MARKINGS



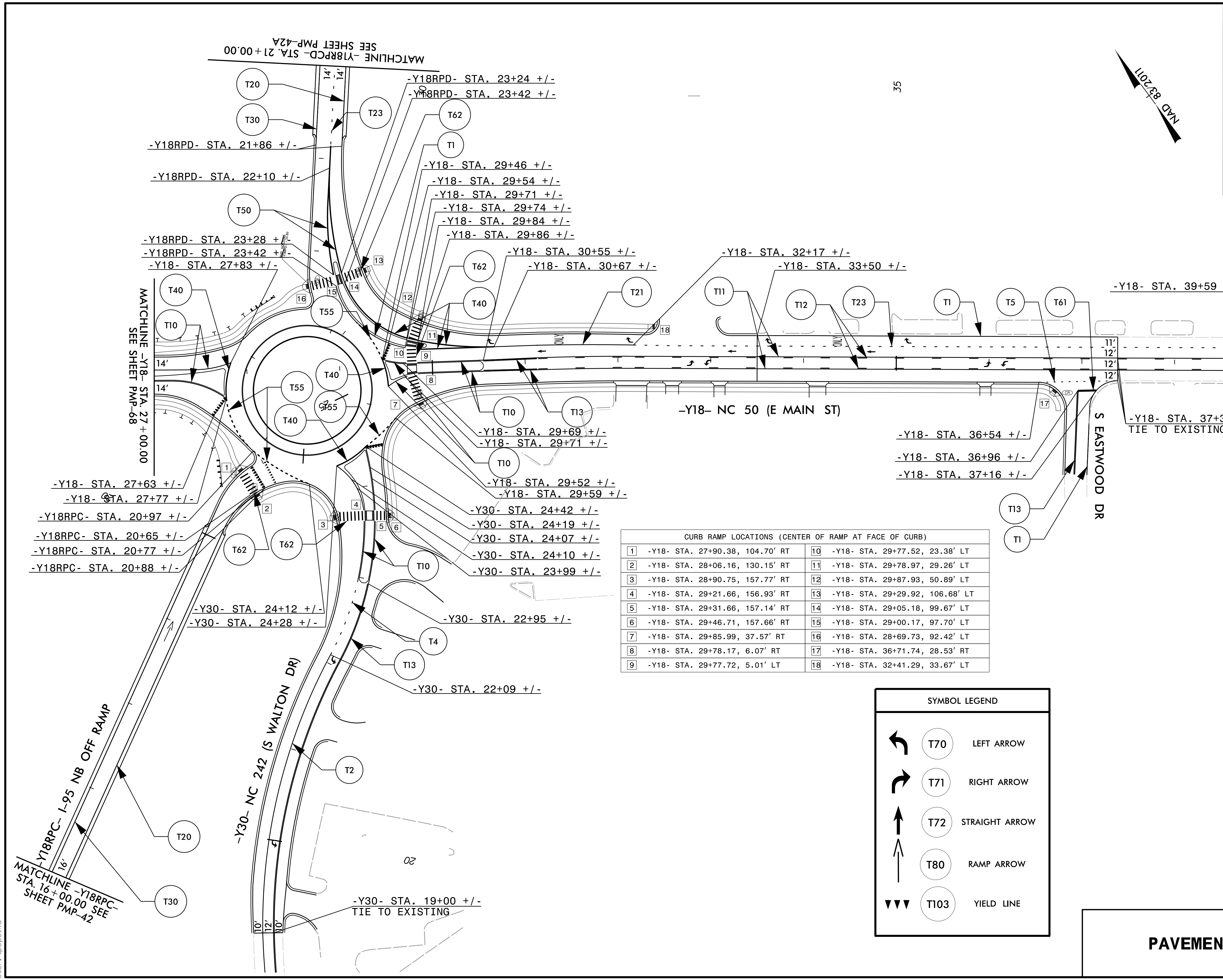

TIP NO. I - 5986B	SHEET NO. PMP - 69
APPROVED: <i>William J. Hamilton</i> AS000704648484	
DATE: 3/15/2021	
SEAL 	
DOCUMENT NOT CONSIDERED FINAL UNLESS ALL SIGNATURES COMPLETED	
 <b>RKA</b> RAMEY KEMP ASSOCIATES 5808 Faringdon Place Raleigh, North Carolina 27609 Phone: 919-872-5115 NC License No. C-0910 www.rameykemp.com	



CURB RAMP LOCATIONS (CENTER OF RAMP AT FACE OF CURB)

1	-Y18- STA. 27+90.38, 104.70' RT	10	-Y18- STA. 29+77.52, 23.38' LT
2	-Y18- STA. 28+06.16, 130.15' RT	11	-Y18- STA. 29+78.97, 29.26' LT
3	-Y18- STA. 28+90.75, 157.77' RT	12	-Y18- STA. 29+87.93, 50.89' LT
4	-Y18- STA. 29+21.66, 156.93' RT	13	-Y18- STA. 29+29.92, 106.68' LT
5	-Y18- STA. 29+31.66, 157.14' RT	14	-Y18- STA. 29+05.18, 99.67' LT
6	-Y18- STA. 29+46.71, 157.66' RT	15	-Y18- STA. 29+00.17, 97.70' LT
7	-Y18- STA. 29+85.99, 37.57' RT	16	-Y18- STA. 28+69.73, 92.42' LT
8	-Y18- STA. 29+78.17, 6.07' RT	17	-Y18- STA. 36+71.74, 28.53' RT
9	-Y18- STA. 29+77.72, 5.01' LT	18	-Y18- STA. 32+41.29, 33.67' LT

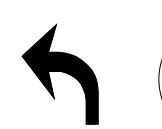
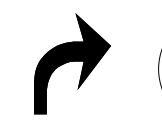
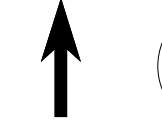
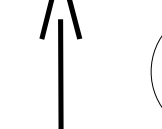
SYMBOL LEGEND

	T70	LEFT ARROW
	T71	RIGHT ARROW
	T72	STRAIGHT ARROW
	T80	RAMP ARROW
	T103	YIELD LINE

**PAVEMENT MARKINGS**

3/19/2021  
 I:\15986B\_1C\_pmp-69.dgn  
 User: tpope@rka