

QUANTITIES FOR ONE PRECAST CONCRETE PILE

LENGTH	APPROX. PILE WT. TONS	ONE PICK-UP POINT		TWO PICK-UP POINT	
		0.300L	0.700L	0.207L	0.586L
10'-0"	1.56	3'-0"	7'-0"		
15'-0"	2.35	4'-6"	10'-6"		
20'-0"	3.14	6'-0"	14'-0"		
25'-0"	3.93	7'-6"	17'-6"		
30'-0"	4.70	9'-0"	21'-0"		
35'-0"	5.49	10'-6"	24'-6"		
40'-0"	6.28	12'-0"	28'-0"		
45'-0"	7.05	13'-6"	31'-6"		
50'-0"	7.84	15'-0"	35'-0"		
55'-0"	8.63			11'-4 1/2"	32'-3"
60'-0"	9.42			12'-5"	35'-2"

NOTES

CONCRETE DESIGN DATA :  $f'_c = 5,000$  PSI

PROPOSED DEVICES FOR LIFTING PILES, RECESS DETAILS, AND PATCHING MATERIAL SHALL BE DETAILED IN SHOP DRAWINGS. AFTER ATTACHMENTS HAVE BEEN REMOVED, OPENINGS SHALL BE REPAIRED SUCH THAT THE APPEARANCE OF THE PILE IS UNIFORM.

WHERE CAST-IN-PLACE LIFTING DEVICES ARE NOT USED, PICK-UP POINTS TO BE INDICATED WITH A BLACK MARK 2" WIDE.

THE SLIP-FORM METHOD OF CASTING PILES WILL NOT BE PERMITTED.

ALL CORNERS TO BE CHAMFERED 1".

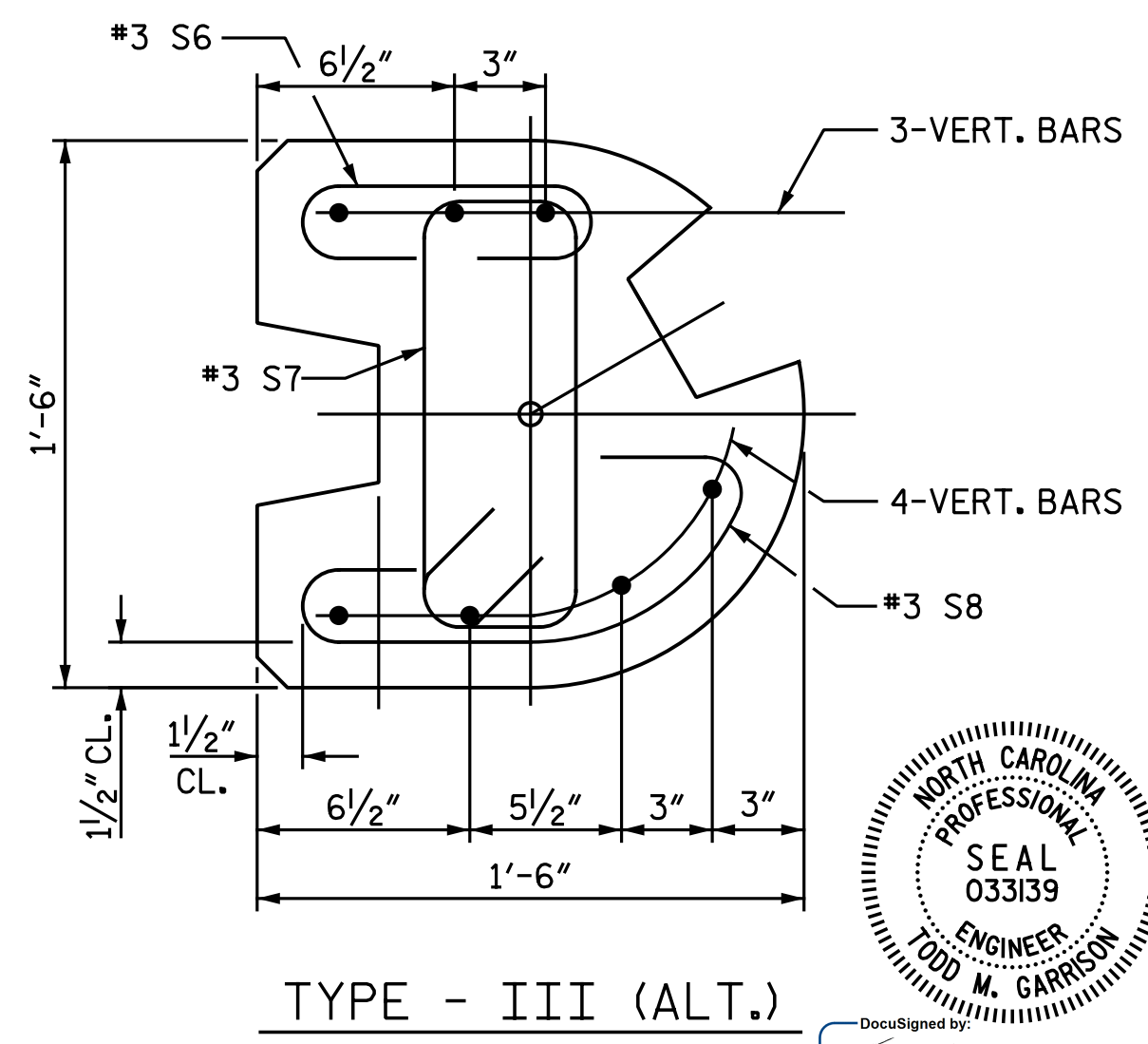
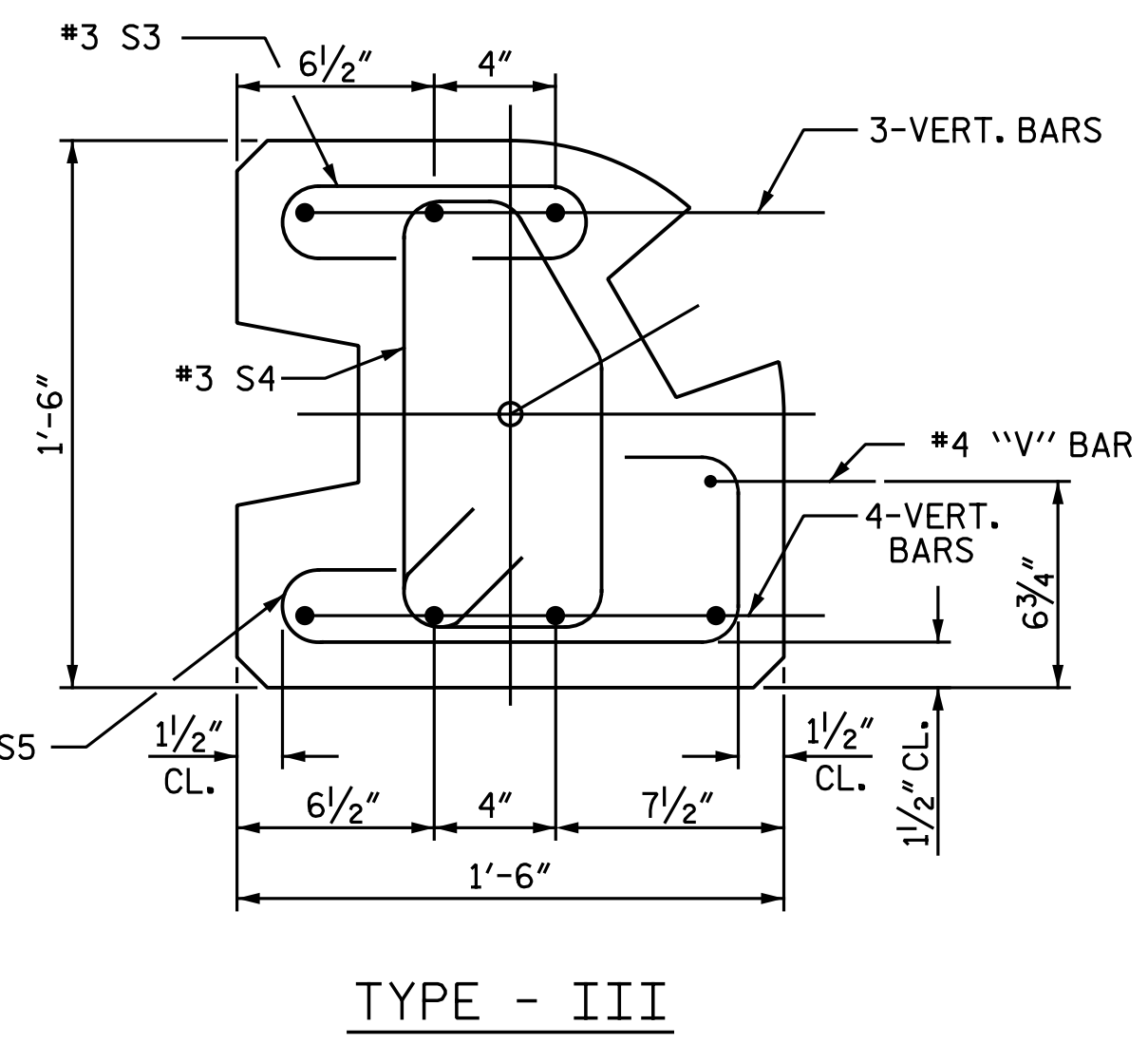
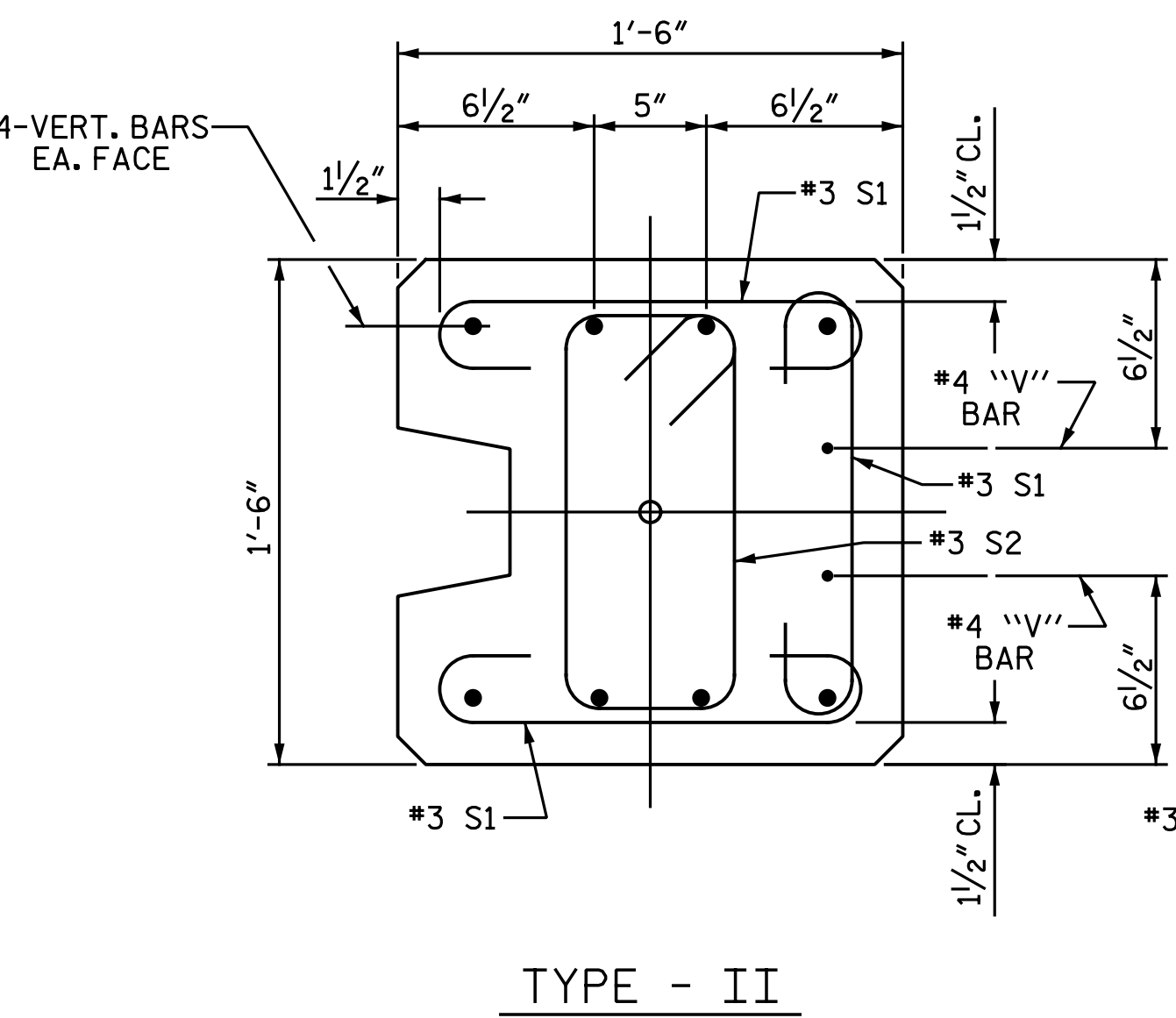
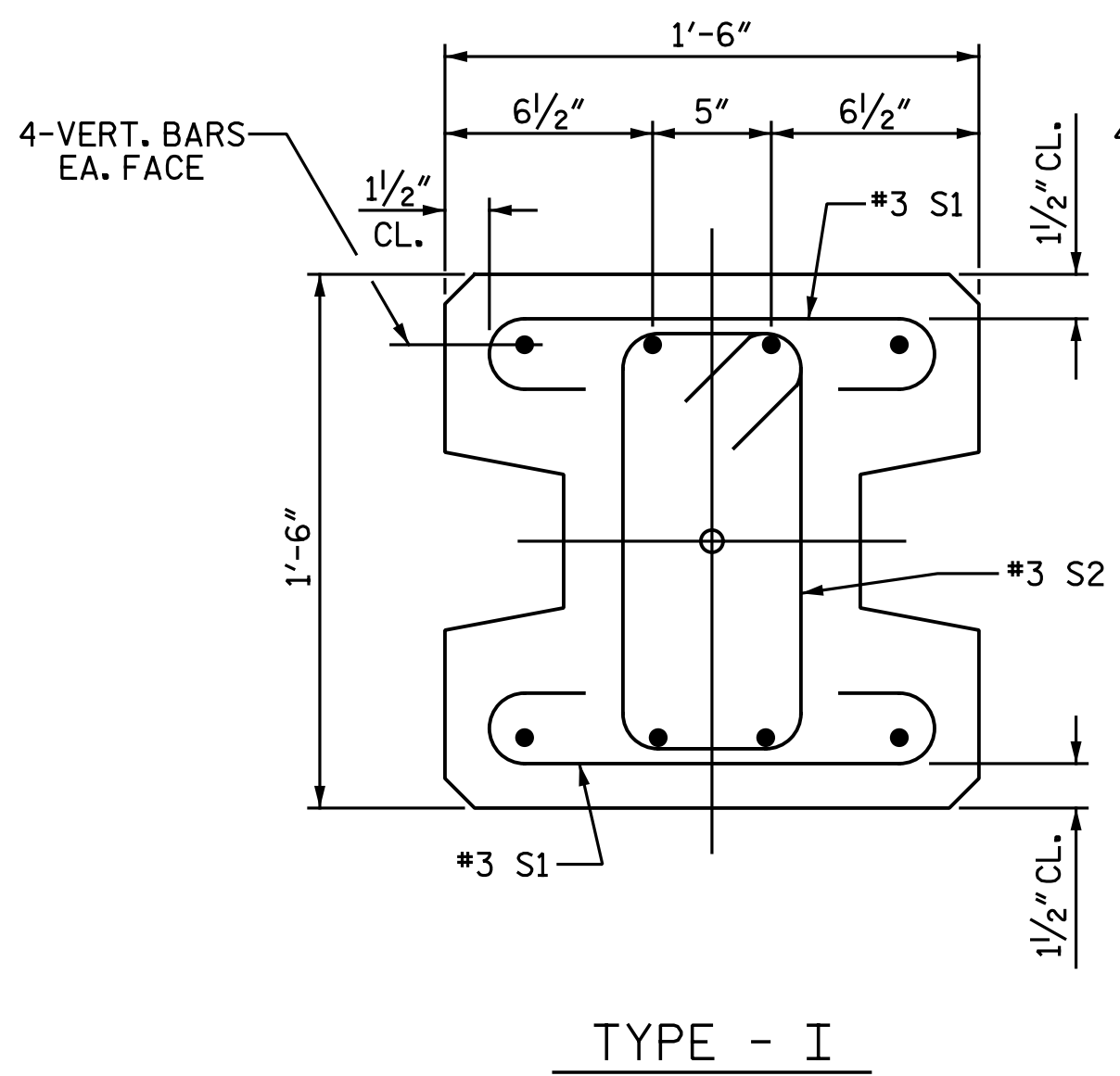
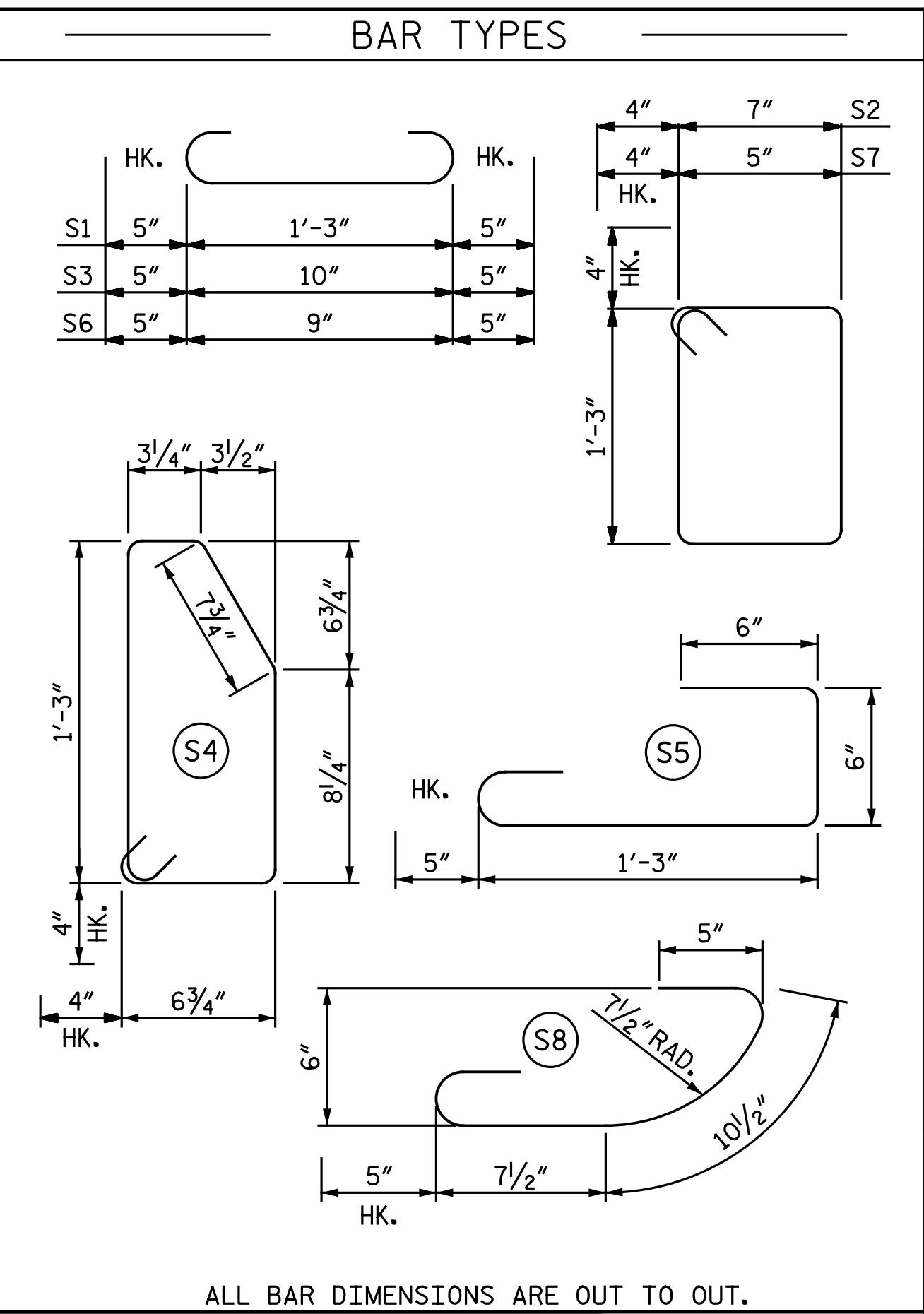

PILE DETAIL

FOR VERTICAL BAR PILE REINFORCING, SEE SHEET 1 OF 3

PROJECT NO. I-5986B  
 HARNETT & JOHNSTON COUNTY  
 STATION: 10+00.00 NW32-1  
 10+00.00 NW33-1  
 SHEET 4 OF 4

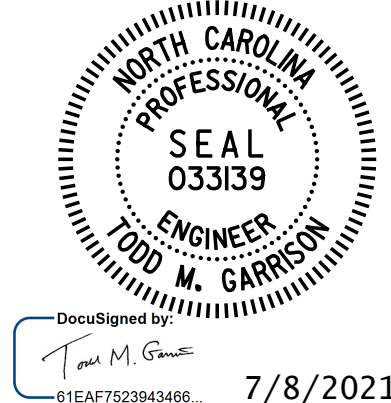

DOCUMENT NOT CONSIDERED FINAL  
 UNLESS ALL SIGNATURES COMPLETED



STATE OF NORTH CAROLINA  
 DEPARTMENT OF TRANSPORTATION  
 RALEIGH  
 STANDARD  
 SOUND BARRIER WALL  
 DETAILS

ASSEMBLED BY : N. B. SPEAKS DATE : 7-8-21  
 CHECKED BY : V. A. PATEL DATE : 7-8-21  
 DRAWN BY : MAA 6/11 REV. 1/15/14 RWW/TMG  
 CHECKED BY : GM 6/11 REV. 12/17 MAA/THC

REVISIONS						SHEET NO.
NO.	BY:	DATE:	NO.	BY:	DATE:	NW-4
1			3			TOTAL SHEETS 4
2			4			

STD. NO. SBW3