

NOTES

THE COST OF THE BARRIER RAIL ON THE APPROACH SLAB SHALL BE INCLUDED IN THE LINEAR FOOT CONTRACT PRICE BID FOR "CONCRETE BARRIER RAIL".

THE BARRIER RAIL ON EACH APPROACH SLAB SHALL NOT BE CAST UNTIL ALL APPROACH SLAB CONCRETE HAS BEEN CAST AND HAS REACHED A MINIMUM COMPRESSIVE STRENGTH OF 3,000 PSI.

ALL REINFORCING STEEL IN BARRIER RAILS SHALL BE EPOXY COATED.

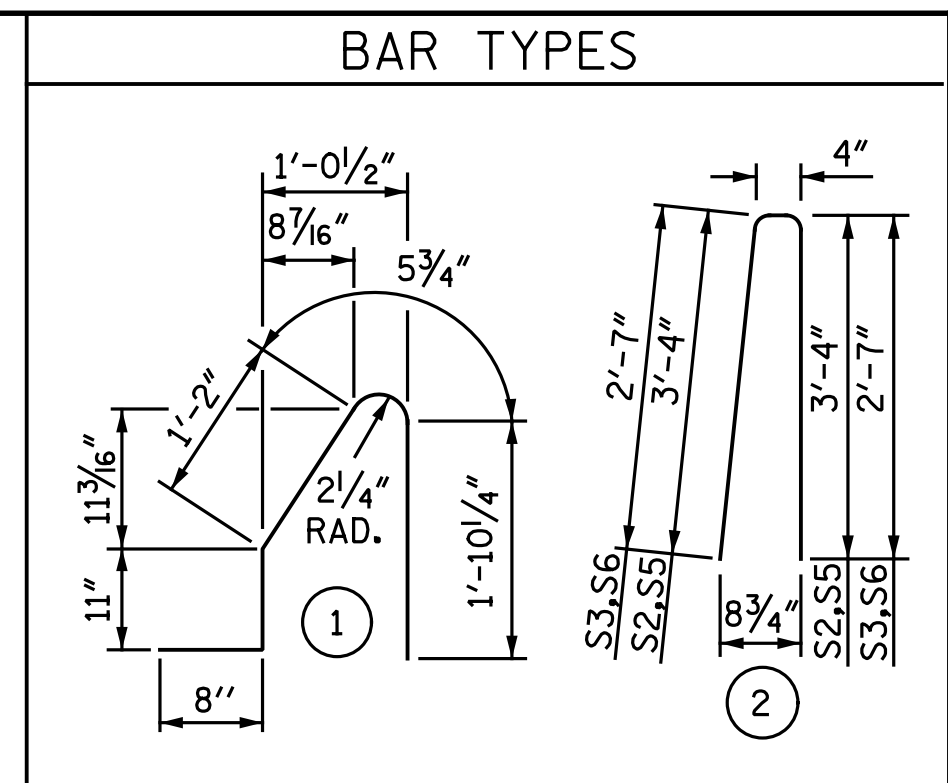

BILL OF MATERIAL

BARRIER RAIL ONLY

STAGE I

BAR	NO.	SIZE	TYPE	LENGTH	WEIGHT
*B1	6	#5	STR.	9' - 11"	62
*B2	11	#5	STR.	9' - 8"	111
*B3	5	#5	STR.	9' - 4"	49
*S1	20	#5	1	5' - 1"	106
*S2	16	#5	2	7' - 0"	117
*S3	4	#5	2	5' - 6"	23

* EPOXY COATED REINFORCING STEEL LBS. 468
CLASS AA CONCRETE C.Y. 2.7
CONCRETE BARRIER RAIL LIN. FT. 20.40

STAGE II

BAR	NO.	SIZE	TYPE	LENGTH	WEIGHT
*B4	6	#5	STR.	9' - 11"	62
*B5	11	#5	STR.	9' - 8"	111
*B6	5	#5	STR.	9' - 4"	49
*S4	20	#5	1	5' - 1"	106
*S5	16	#5	2	7' - 0"	117
*S6	4	#5	2	5' - 6"	23

* EPOXY COATED REINFORCING STEEL LBS. 468
CLASS AA CONCRETE C.Y. 2.7
CONCRETE BARRIER RAIL LIN. FT. 20.40

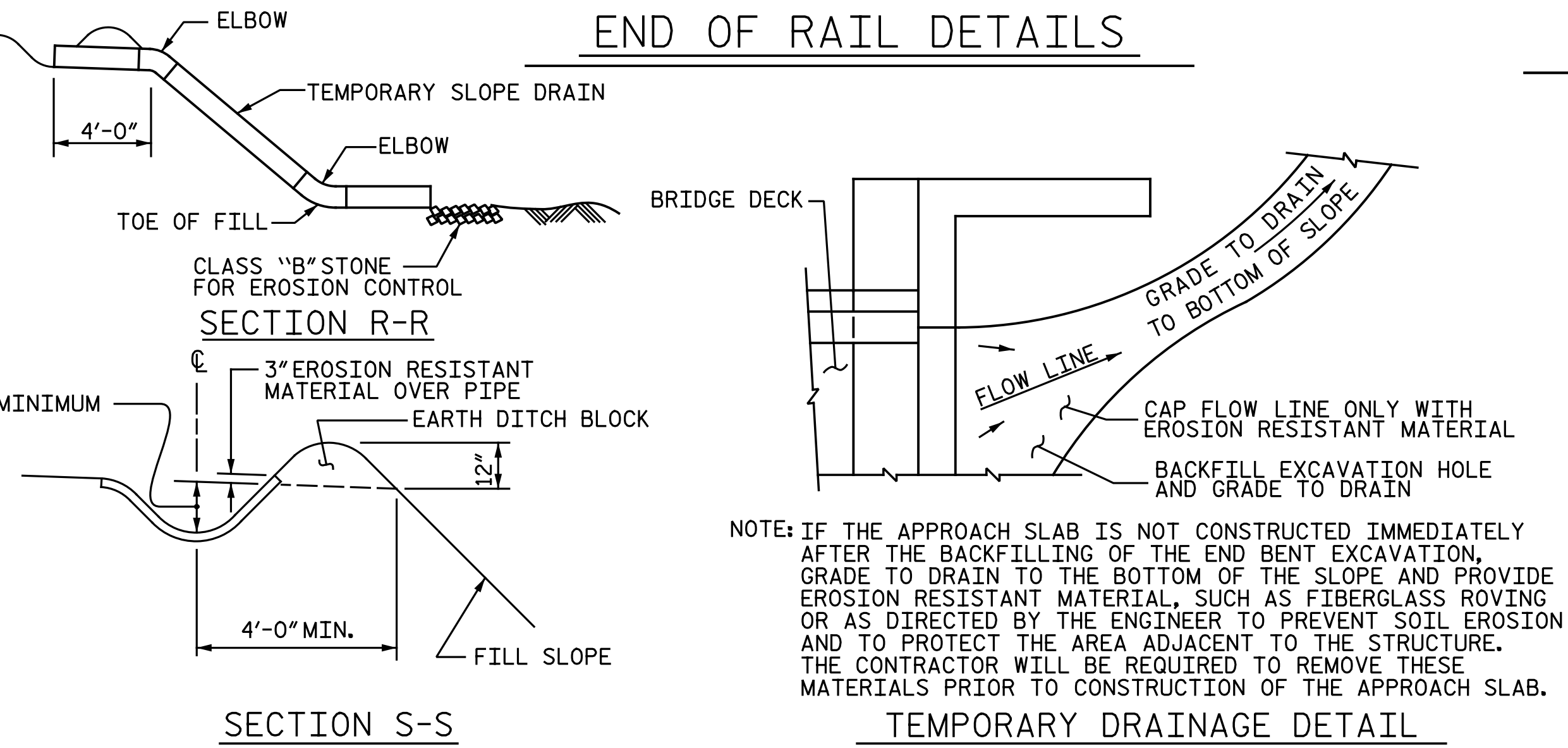
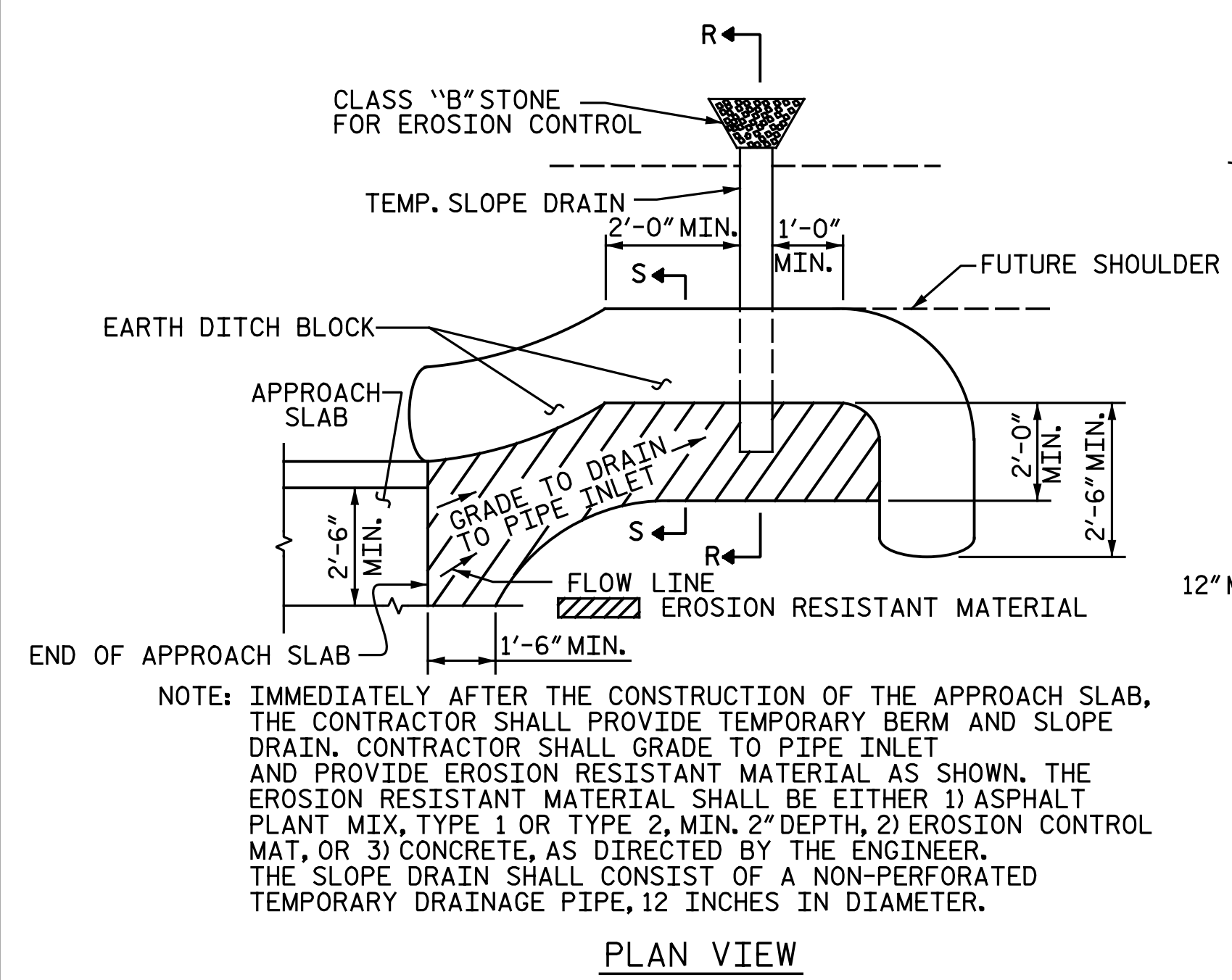
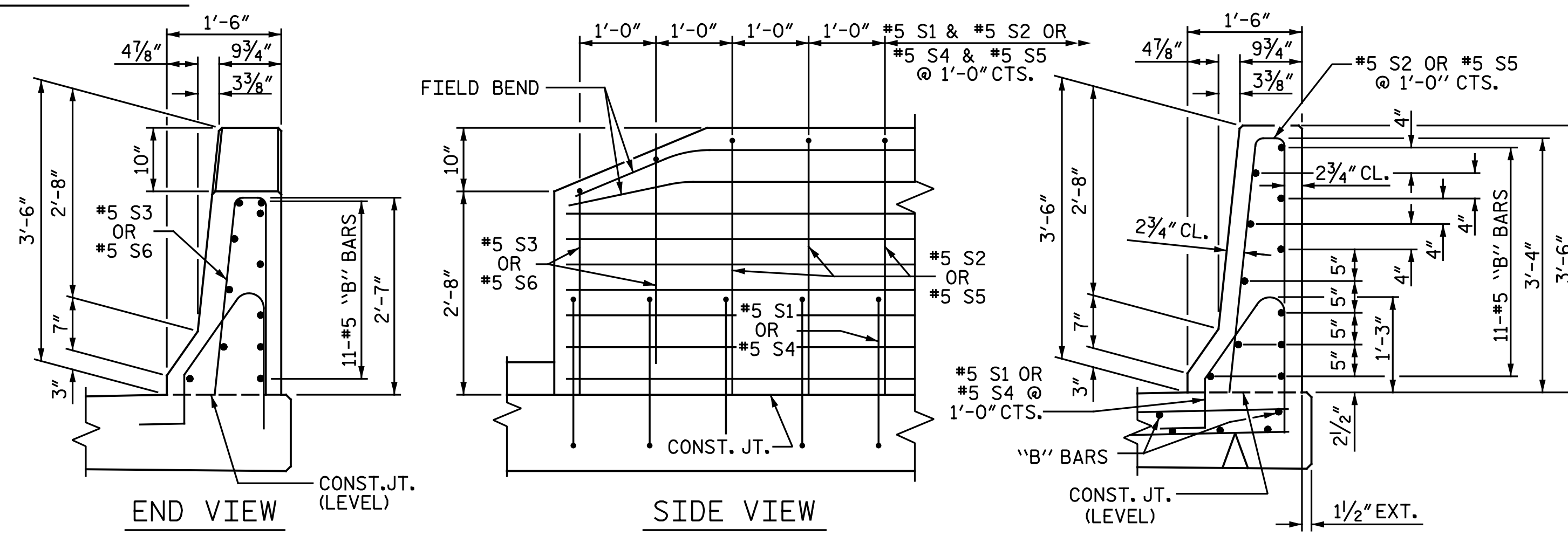

TEMPORARY BERM AND SLOPE DRAIN DETAILS
(TO BE USED WHEN SHOULDER BERM GUTTER IS REQUIRED)

PROJECT NO. I-5878
HARNETT COUNTY
STATION: 1002+79.68 -LREV-
SHEET 2 OF 3

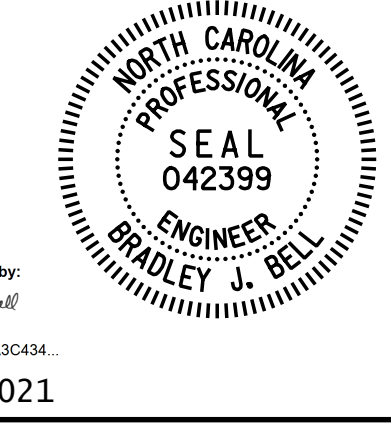

STATE OF NORTH CAROLINA
DEPARTMENT OF TRANSPORTATION
RALEIGH
STANDARD
BRIDGE APPROACH
SLAB DETAILS 1

ASSEMBLED BY : N. B. SPEAKS
CHECKED BY : B. J. BELL
DATE : 3-27-19
DATE : 5-8-19

DRAWN BY : FCJ 11/88
CHECKED BY : ARB 11/88

REV. 6/13
REV. 12/17
REV. 5/18

MAA/GM
MAA/THC
MAA/THC

DOCUMENT NOT CONSIDERED FINAL
UNLESS ALL SIGNATURES COMPLETED

Michael Baker INTERNATIONAL
Michael Baker Engineering
8000 Regency Parkway, Suite 600
Cary, North Carolina 27518
NC License No. : F-1084

REVISIONS						SHEET NO. S2-33
NO.	BY:	DATE:	NO.	BY:	DATE:	
1			3			TOTAL SHEETS
2			4			34

STD. NO. BAS4