

DEAD LOAD DEFLECTION TABLE FOR SPAN A

0.6" Ø LOW RELAXATION	BEAMS 1, 4 THRU 6, 10 THRU 13 & 16										
TENTH POINTS	0.00	0.10	0.20	0.30	0.40	0.50	0.60	0.70	0.80	0.90	1.00
CAMBER (BEAM ALONE IN PLACE)	0.000	0.124	0.234	0.320	0.374	0.393	0.374	0.320	0.234	0.124	0.000
DEFLECTION DUE TO SUPERIMPOSED D.L. *	0.000	0.067	0.131	0.181	0.213	0.224	0.213	0.181	0.131	0.067	0.000
FINAL CAMBER	0"	1 1/16"	1 1/4"	1 11/16"	1 5/8"	2 1/16"	1 5/8"	1 11/16"	1 1/4"	1 1/16"	0"

0.6" Ø LOW RELAXATION	BEAMS 2, 3, 7, 9, 14 & 15										
TENTH POINTS	0.00	0.10	0.20	0.30	0.40	0.50	0.60	0.70	0.80	0.90	1.00
CAMBER (BEAM ALONE IN PLACE)	0.000	0.124	0.234	0.320	0.374	0.393	0.374	0.320	0.234	0.124	0.000
DEFLECTION DUE TO SUPERIMPOSED D.L. *	0.000	0.069	0.136	0.188	0.221	0.232	0.221	0.188	0.136	0.069	0.000
FINAL CAMBER	0"	5/8"	1 3/16"	1 9/16"	1 7/8"	1 5/16"	1 7/8"	1 9/16"	1 3/16"	5/8"	0"

0.6" Ø LOW RELAXATION	BEAM 8										
TENTH POINTS	0.00	0.10	0.20	0.30	0.40	0.50	0.60	0.70	0.80	0.90	1.00
CAMBER (BEAM ALONE IN PLACE)	0.000	0.124	0.234	0.320	0.374	0.393	0.374	0.320	0.234	0.124	0.000
DEFLECTION DUE TO SUPERIMPOSED D.L. *	0.000	0.076	0.148	0.204	0.240	0.253	0.240	0.204	0.148	0.076	0.000
FINAL CAMBER	0"	9/16"	1"	1 3/8"	1 5/8"	1 11/16"	1 5/8"	1 3/8"	1"	9/16"	0"

* INCLUDES FUTURE WEARING SURFACE.
ALL VALUES ARE SHOWN IN FEET (DECIMAL FORM), EXCEPT "FINAL CAMBER", WHICH IS GIVEN IN INCHES (FRACTION FORM).

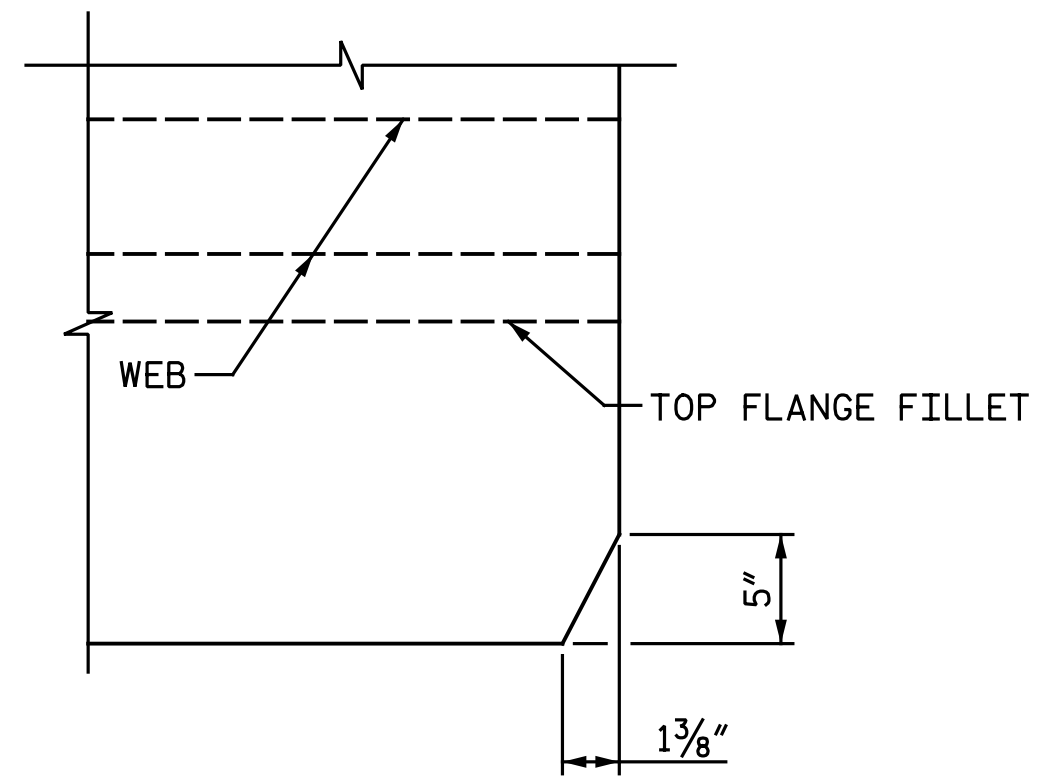

TOP FLANGE CLIP DETAIL
(EXPANSION END SHOWN, FIXED END SIMILAR)

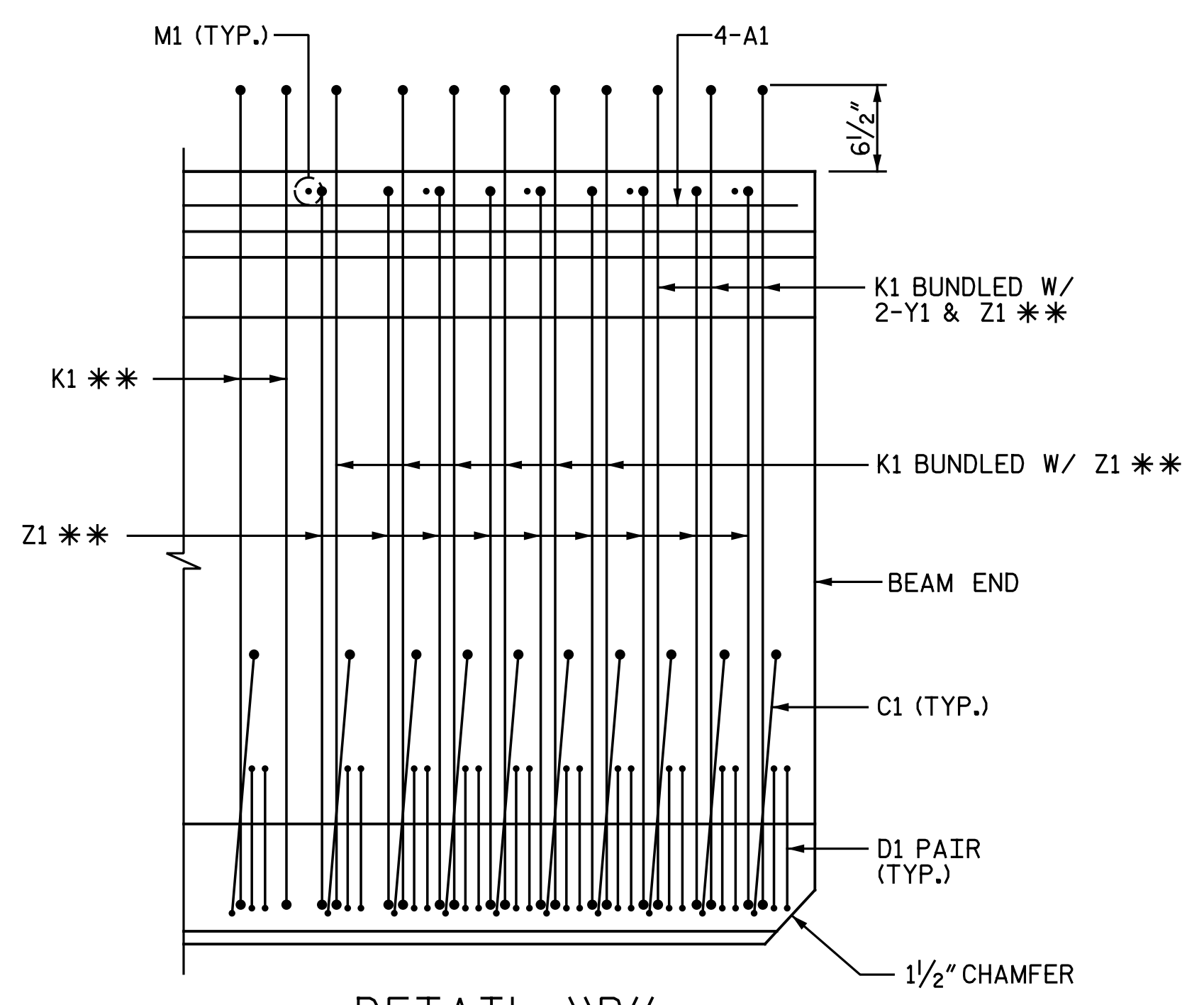
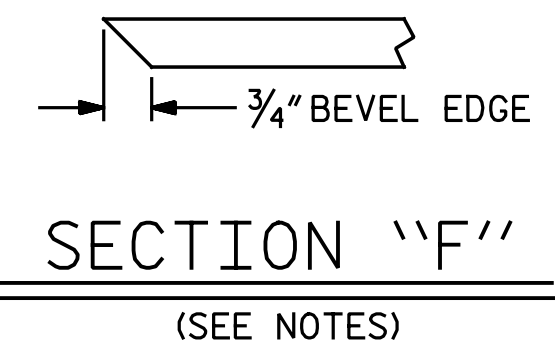

DETAIL "B"
(EXPANSION END SHOWN, FIXED END SIMILAR)

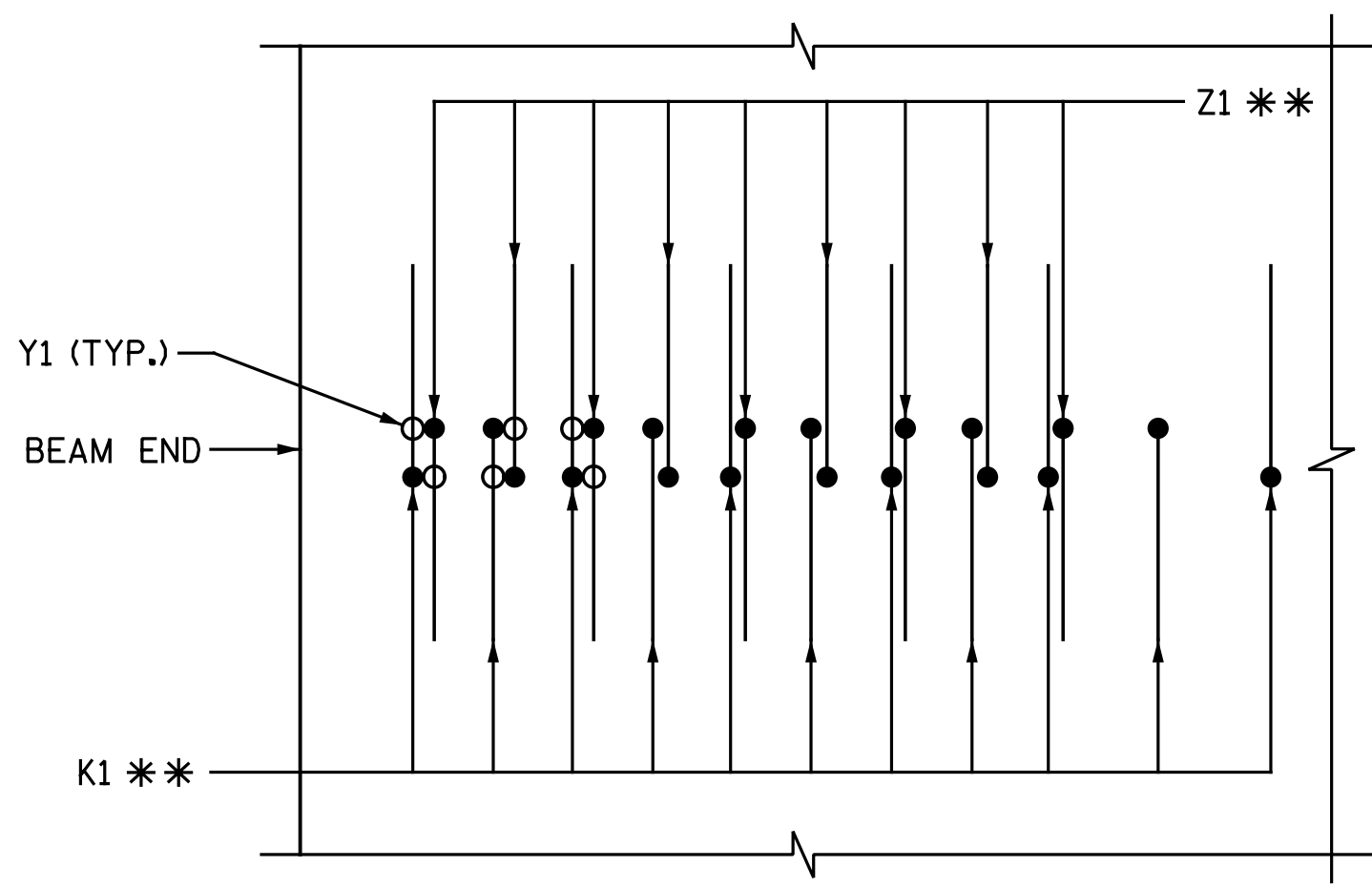

DETAIL "A"
(SHOWING ONLY K1, Y1 & Z1 BARS)
(FIXED END SHOWN, EXPANSION END SIMILAR)

** ALTERNATE DIRECTION OF BAR ENDS

NOTES

- ALL PRESTRESSING STRANDS SHALL BE 7-WIRE LOW-RELAXATION GRADE 270 STRANDS AND SHALL CONFORM TO AASHTO M203 EXCEPT FOR SAMPLING REQUIREMENTS WHICH SHALL BE IN ACCORDANCE WITH THE STANDARD SPECIFICATIONS.
- ALL REINFORCING STEEL SHALL BE GRADE 60.
- APPLY EPOXY PROTECTIVE COATING TO END OF BEAM SURFACES INDICATED IN ELEVATION VIEW.
- EMBEDDED PLATE "B-1" SHALL BE GALVANIZED IN ACCORDANCE WITH THE STANDARD SPECIFICATIONS.
- ANCHOR STUDS SHALL CONFORM TO AASHTO M169 GRADES 1010 THROUGH 1020 OR APPROVED EQUAL, AND SHALL MEET THE TYPE "B" REQUIREMENTS OF SUBSECTION 7.3 OF THE ANSI/AASHTO/AWS D1.5 BRIDGE WELDING CODE.
- PRESTRESSING STRANDS SHALL BE CUT FLUSH WITH THE BEAM ENDS.
- THE TRANSFER OF LOAD FROM THE ANCHORAGES TO THE BEAM SHALL BE DONE WHEN CONCRETE HAS REACHED A COMPRESSIVE STRENGTH OF NOT LESS THAN 6,000 PSI.
- DEPENDING ON THE TYPE OF SYSTEM USED TO SUPPORT THE DECK SLAB FORMS, PRESET ANCHORS MAY BE NECESSARY IN THE PRESTRESSED CONCRETE BEAM.
- THE TOP SURFACE OF THE BEAM, EXCLUDING THE OUTSIDE 4", SHALL BE RAKED TO A DEPTH OF 1/4".
- WHEN DRAPED STRANDS ARE DETAILED, THE LONGITUDINAL LOCATION OF THE HOLD DOWN DEVICES SHALL BE WITHIN 6" OF THE LOCATION SHOWN AND THE CENTER OF GRAVITY OF THE GROUP OF DRAPED STRANDS SHALL BE LOCATED WITHIN 1/2" OF THE THEORETICAL LOCATION SHOWN.
- TIE "K" AND "Z" BARS TO FULLY BONDED STRANDS IN THE BOTTOM OR CENTER ROW.
- FOR 45" PRESTRESSED CONCRETE FLORIDA I-BEAM, SEE SPECIAL PROVISIONS.

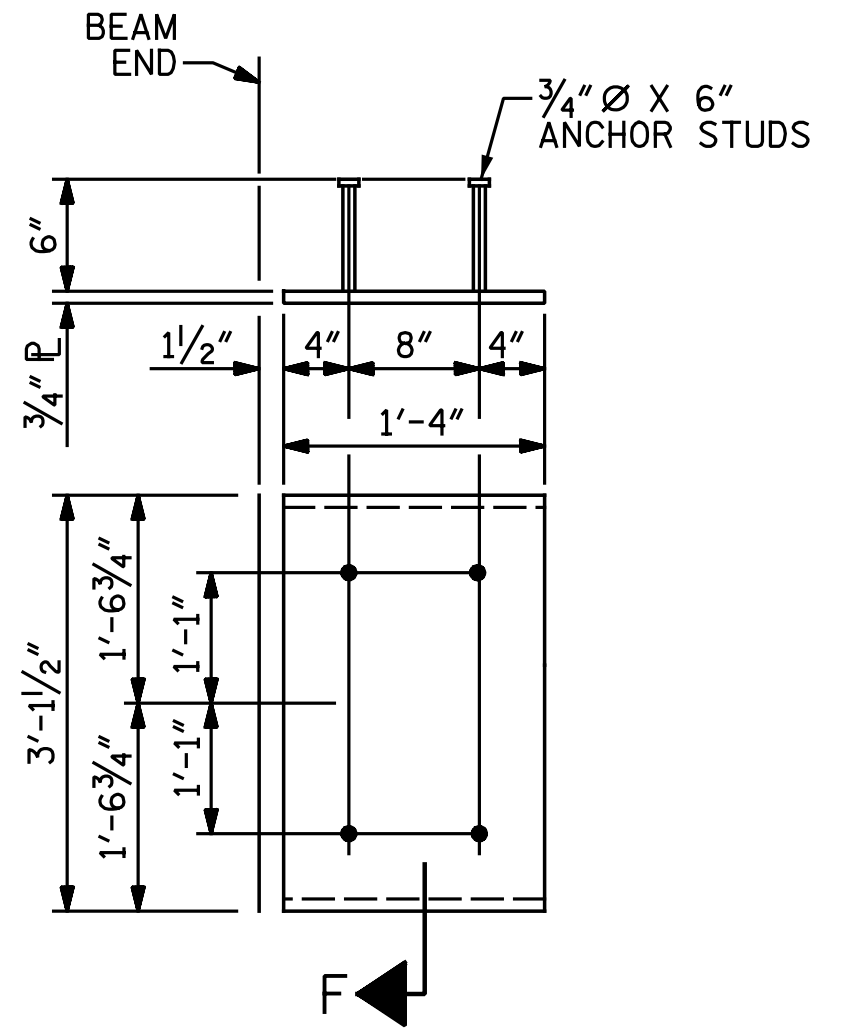

EMBEDDED PLATE "B-1" DETAILS
FOR FLORIDA I-BEAMS
(2 REQ'D PER BEAM)

PROJECT NO. I-5878
HARNETT COUNTY
STATION: 1002+79.68 -LREV-

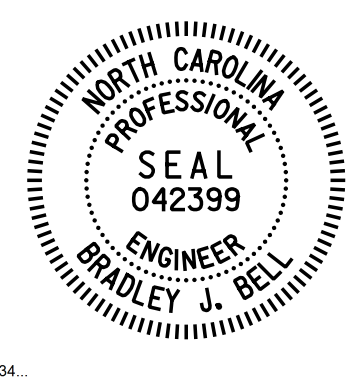

Designed by:
Michael Baker Engineering
4/22/2021

DOCUMENT NOT CONSIDERED FINAL
UNLESS ALL SIGNATURES COMPLETED

Michael Baker International
Michael Baker Engineering
8000 Regency Parkway, Suite 600
Cary, North Carolina 27518
NC License No.: F-1084

STATE OF NORTH CAROLINA
DEPARTMENT OF TRANSPORTATION
RALEIGH
SUPERSTRUCTURE
45" PRESTRESSED
CONCRETE
FLORIDA I-BEAM
DETAILS

REVISIONS						SHEET NO.
NO.	BY:	DATE:	NO.	BY:	DATE:	S2-14
1			3			TOTAL SHEETS
2			4			34

DRAWN BY: N. B. SPEAKS DATE: 5-6-19
CHECKED BY: B. J. BELL DATE: 9-18-19