

△ DIMENSION TO BE ADJUSTED AS REQUIRED IN FIELD TO MATCH MSE WALL.  
 † DIMENSION NORMAL TO END BENT

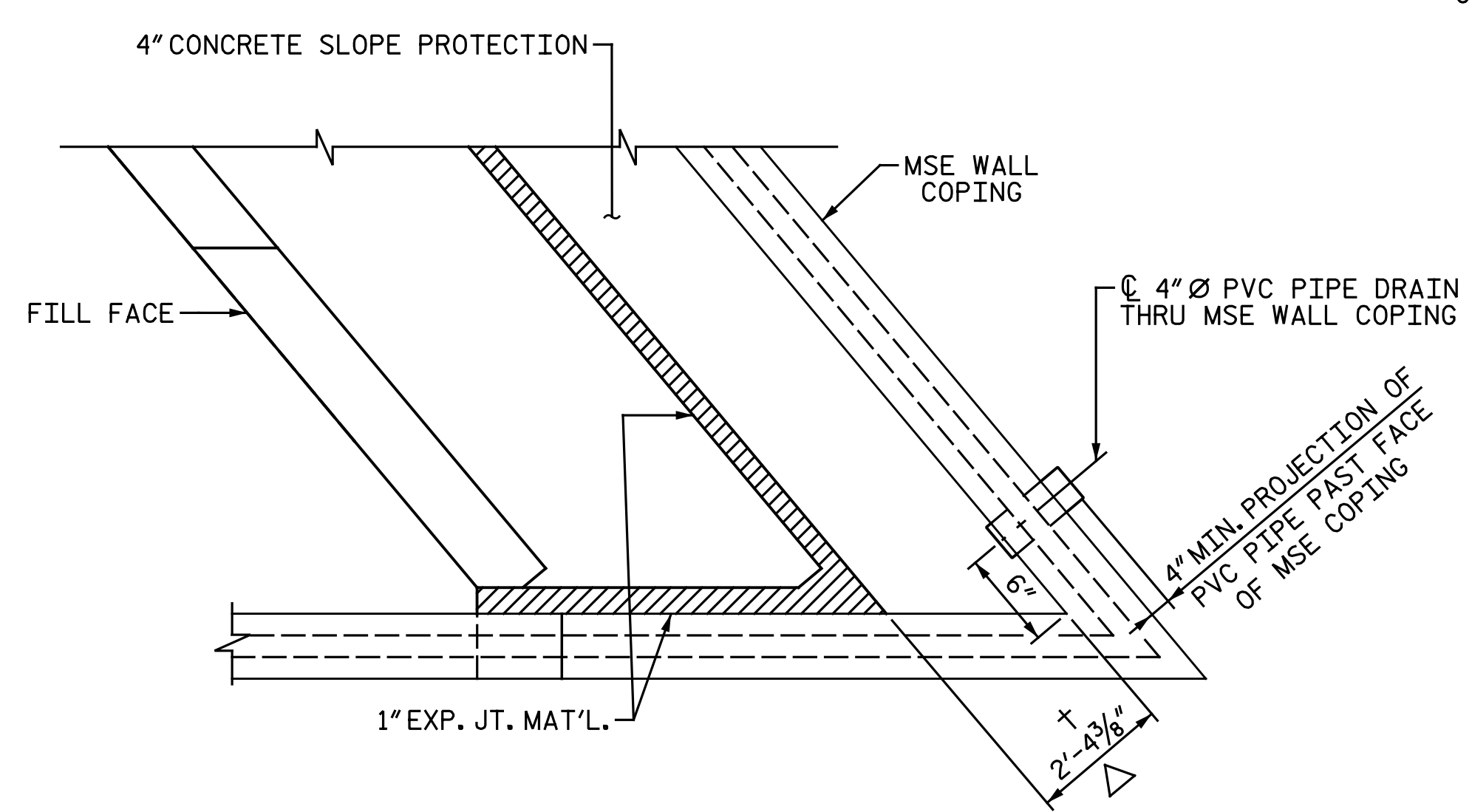
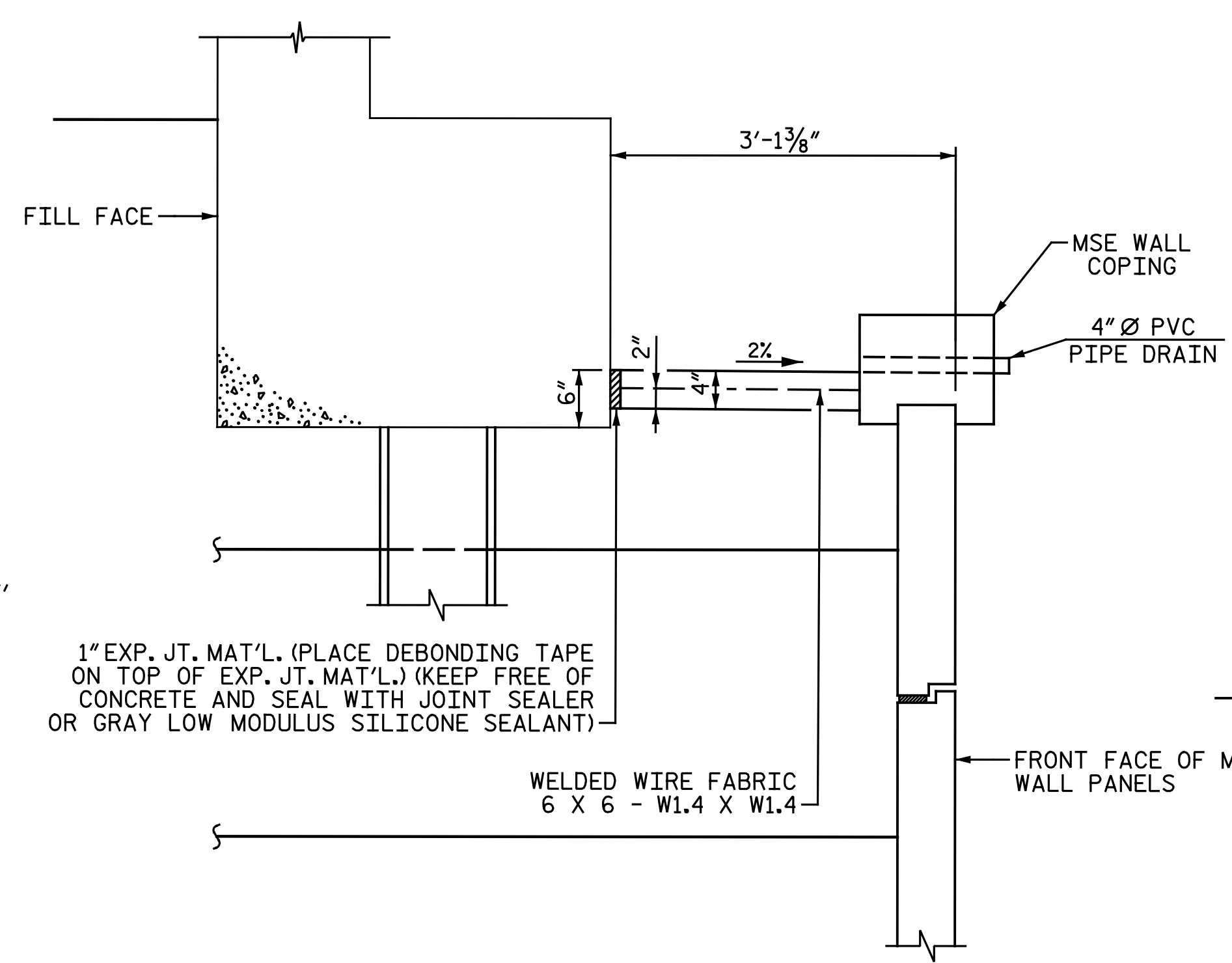
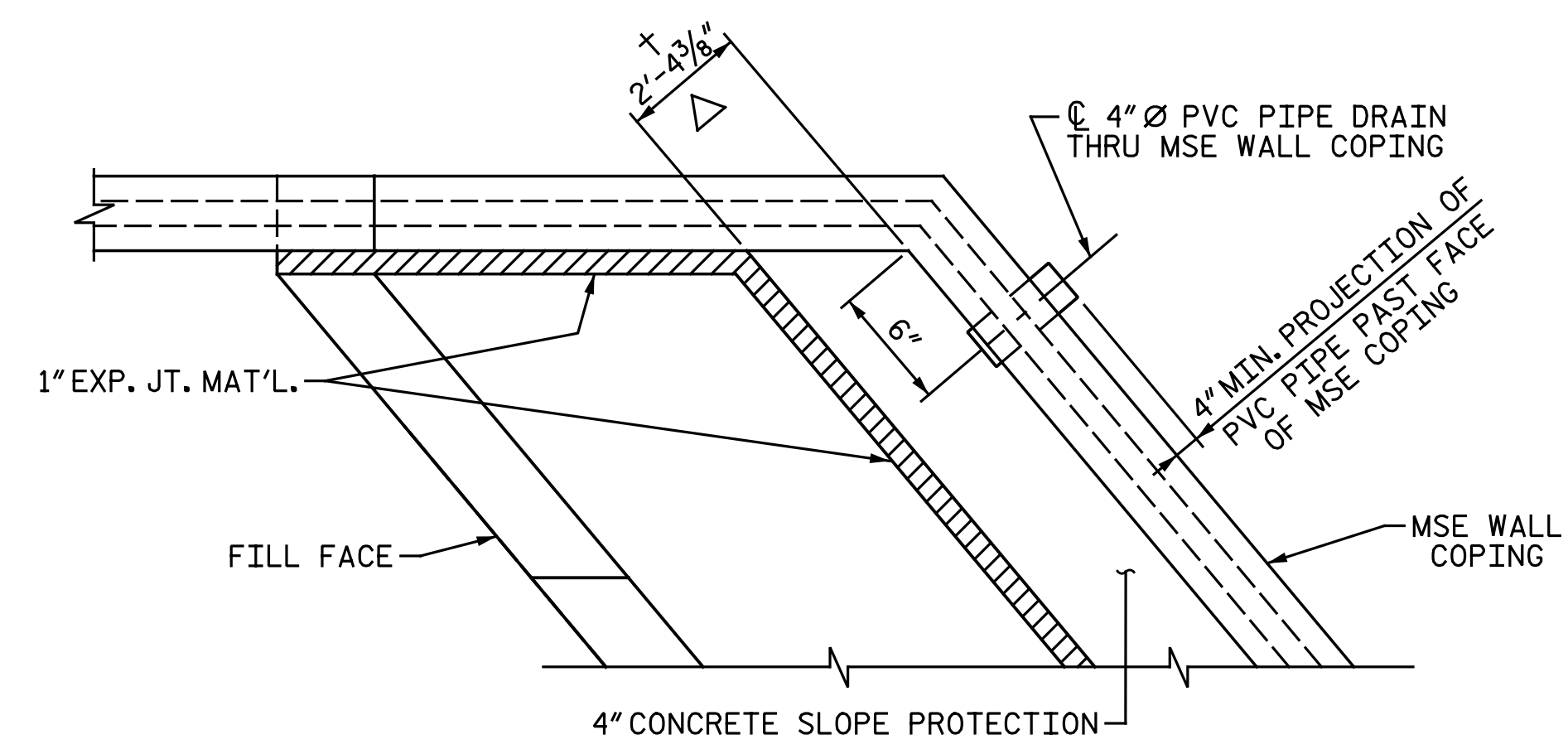

**NOTES:**  
 SLOPE PROTECTION SHALL BE PLACED UNDER THE ENDS OF THE BRIDGE AS SHOWN IN THE DETAILS. MEASUREMENT AND PAYMENT SHALL BE AS PRESCRIBED IN SECTION 462 OF THE STANDARD SPECIFICATIONS.  
 SLOPE PROTECTION SHALL CONSIST OF 4" POURED-IN-PLACE CONCRETE PAVING AS SHOWN IN THE DETAILS ON THIS SHEET. CONCRETE SHALL BE CLASS "B". THE CONCRETE SURFACE SHALL BE FLOATED WITH A WOODEN FLOAT AND FINISHED. WELDED WIRE FABRIC REINFORCING SHALL BE 6 X 6 - W1.4 X W1.4, 60" WIDE. SLOPE PROTECTION SHALL BE POURED IN 5' STRIPS AS SHOWN IN THE "POURING DETAIL" WITH 2'-0" LONG #4 BARS PLACED ALONG THE SLOPE BETWEEN STRIPS AT 1'-6" MAXIMUM SPACING. SLOPE PROTECTION MAY BE POURED IN ALTERNATE 4' AND 5' STRIPS AS SHOWN IN THE "OPTIONAL POURING DETAIL" WITH ADJACENT RUNS OF WELDED WIRE FABRIC LAPPING AT LEAST 6". THE COST OF THE WELDED WIRE FABRIC AND #4 BARS, IF USED, SHALL BE INCLUDED IN THE CONTRACT UNIT PRICE BID PER SQUARE YARD FOR SLOPE PROTECTION.  
 SEE "SLOPE PROTECTION DETAILS" SHEET 2 OF 2 FOR END BENT 2 QUANTITIES.

BRIDGE @ STA. 26+80.73 -Y17-	4 INCH SLOPE PROTECTION	* WELDED WIRE FABRIC 60 INCHES WIDE
	SQUARE YARDS	APPROX. L.F.
END BENT 1	19	38

\* QUANTITY SHOWN IS BASED ON 5' POURS.

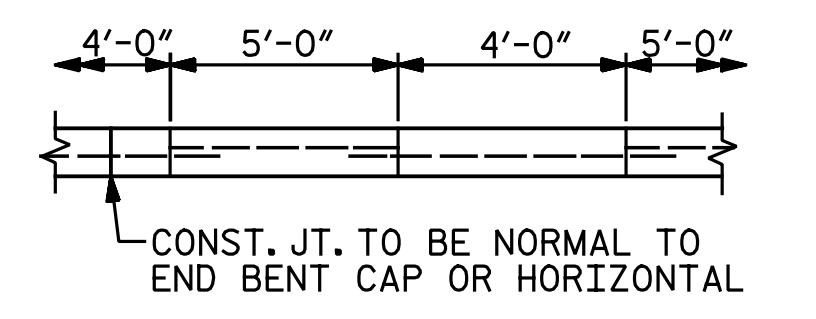
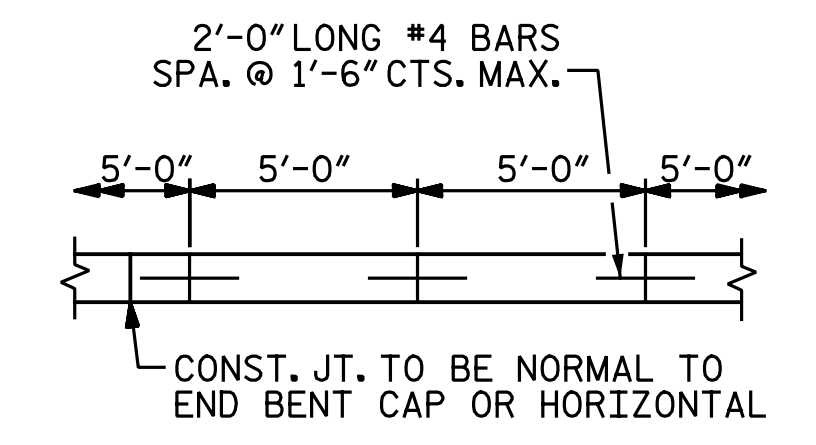

POUR A 4'-0" STRIP FIRST.

PROJECT NO. I-5883  
HARNETT COUNTY  
 STATION: 26+80.73 -Y17-

SHEET 1 OF 2

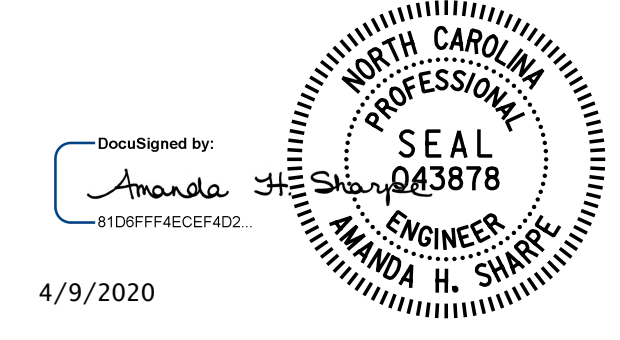

4/9/2020

DOCUMENT NOT CONSIDERED FINAL  
 UNLESS ALL SIGNATURES COMPLETED

**Michael Baker International**  
 Michael Baker Engineering  
 8000 Regency Parkway, Suite 600  
 Cary, North Carolina 27518  
 NC License No.: F-1084

STATE OF NORTH CAROLINA DEPARTMENT OF TRANSPORTATION RALEIGH					
SLOPE PROTECTION DETAILS					
REVISIONS					
NO.	BY:	DATE:	NO.	BY:	DATE:
1			3		
2			4		

SHEET NO. S2-30	TOTAL SHEETS 33
--------------------	--------------------

DRAWN BY : N. B. SPEAKS DATE : 11-2-18  
 CHECKED BY : A. H. SHARPE DATE : 11-2-18