

NOTES:

FOR "SECTION A-A", "PARTIAL SECTION B-B", "PARTIAL SECTION C-C" AND "PARTIAL SECTION D-D", SEE "END BENT 1 DETAILS" SHEET.

STIRRUPS & U2 BARS IN CAP MAY BE SHIFTED AS NECESSARY TO CLEAR ANCHOR BOLTS.

BACKWALL SHALL BE PLACED BEFORE APPLYING THE EPOXY PROTECTIVE COATING.

THE TOP SURFACE AREAS OF THE END BENT CAP SHALL BE CURED IN ACCORDANCE WITH THE STANDARD SPECIFICATIONS EXCEPT THE MEMBRANE CURING COMPOUND METHOD SHALL NOT BE USED.

THE TOP SURFACE OF THE CAP EXCEPT THE BRIDGE SEAT BUILDUPS SHALL BE SLOPED TRANSVERSELY FROM THE FILL FACE TO THE BACK FACE AT THE RATE OF 2%.

THE CONCRETE IN THE HATCHED AREA OF THE WING SHALL BE POURED AFTER THE BARRIER RAIL IS CAST IF SLIP FORMING IS USED.

FOR MSE WALLS, SEE SPECIAL PROVISIONS.

FOR LOCATION OF MSE WALL AND PILE SLEEVES, SEE MSE WALL PLANS.

LENGTH OF CAP AND EACH WING SHALL BE FIELD ADJUSTED AS REQUIRED TO PROVIDE 1" EXPANSION JOINT MATERIAL AS SHOWN BETWEEN THESE COMPONENTS AND THE MSE WALL COPING.

FOR PILE SPLICE DETAILS, SEE "END BENT 2 DETAILS" SHEET.

V1 & K1 BARS IN BACKWALL MAY BE SHIFTED AS NECESSARY TO CLEAR CONDUIT OPENING.

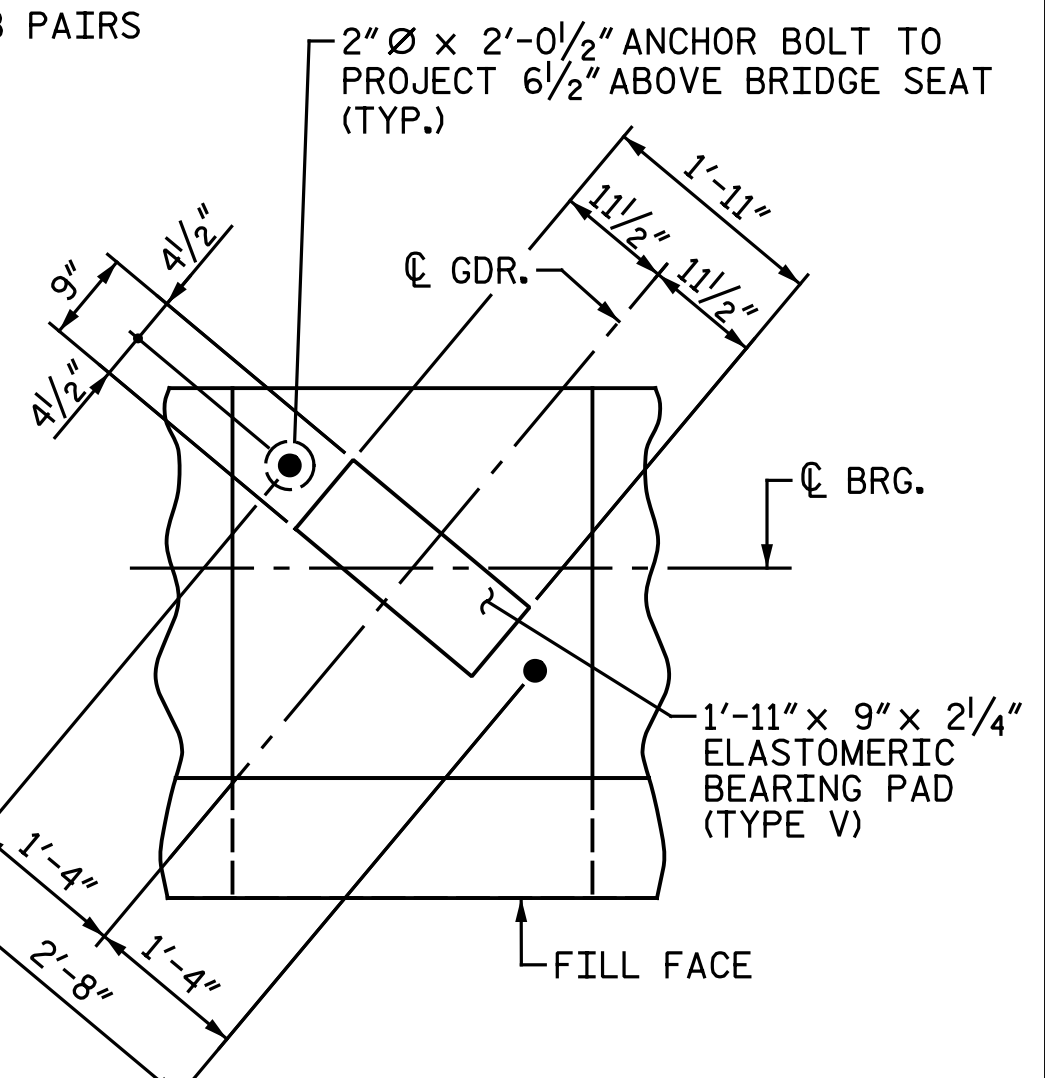
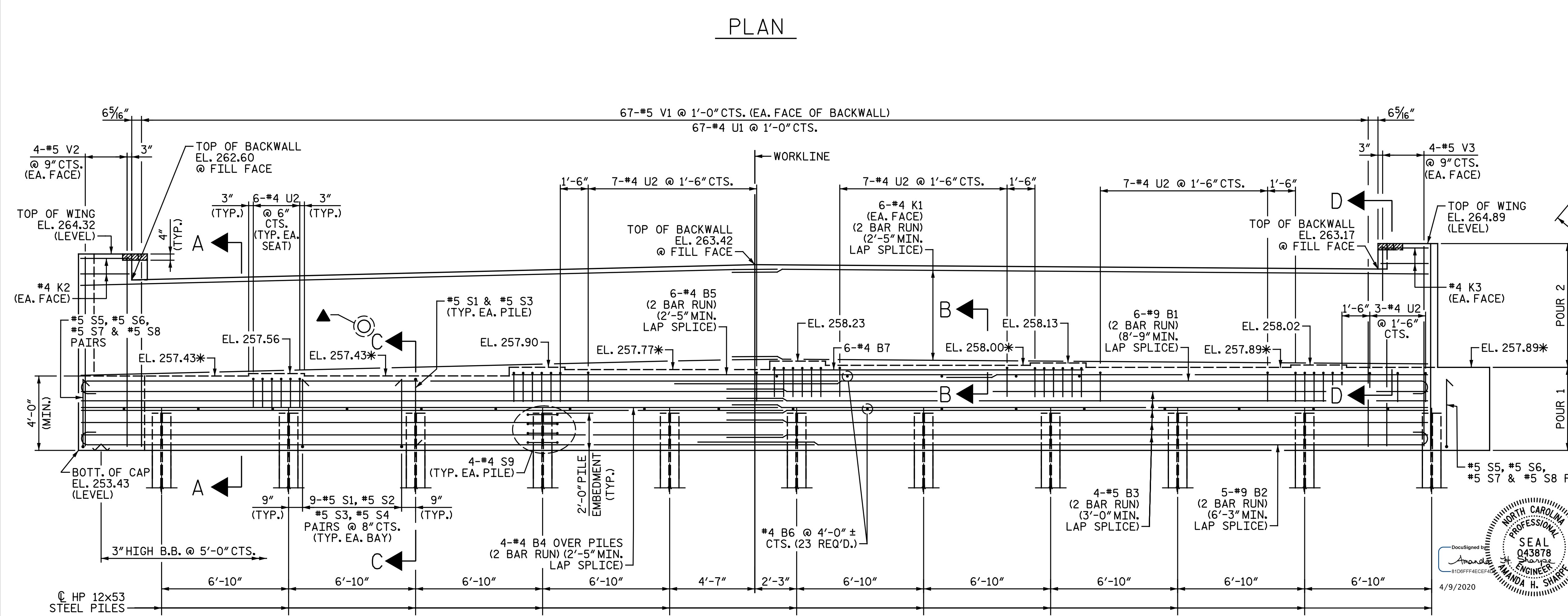

PROJECT NO. I-5883
 HARNETT COUNTY
 STATION: 26+80.73 -Y17-

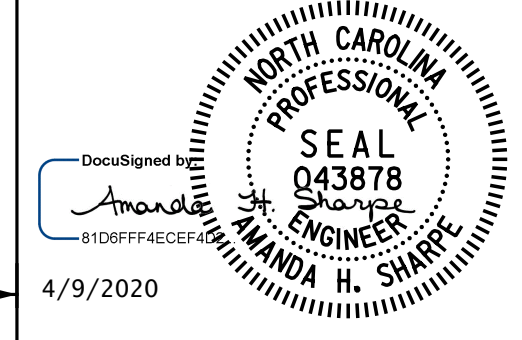

STATE OF NORTH CAROLINA
 DEPARTMENT OF TRANSPORTATION
 RALEIGH
 SUBSTRUCTURE
 END BENT 1

DRAWN BY: C. E. MAYHEW DATE: 1-10-19
 CHECKED BY: A. H. SHARPE DATE: 12-3-19

*FOR LOCATION OF ELEVATIONS BETWEEN BRIDGE SEAT BUILD UPS, SEE "SECTION A-A" ON "END BENT 1 DETAILS" SHEET.
 ▲ CONDUIT OPENING, SEE DETAIL "E" ON "END BENT 1 DETAILS" SHEET.

DOCUMENT NOT CONSIDERED FINAL
 UNLESS ALL SIGNATURES COMPLETED

NO.	BY:	DATE:	REVISIONS			SHEET NO.
			NO.	BY:	DATE:	
1			3			S2-23 TOTAL SHEETS 33
2			4			

Michael Baker International
 Michael Baker Engineering
 8000 Regency Parkway, Suite 600
 Cary, North Carolina 27518
 NC License No.: F-1084