

**NOTES:**  
 UNLESS NOTED OTHERWISE RETAIN ALL EXISTING REINFORCING STEEL. CLEAN AND REPAIR AS NEEDED.  
 SILICONE JOINT SEALANT AND BACKER ROD SHALL BE INSTALLED AS PER MANUFACTURER'S RECOMMENDATION.  
 THE INSTALLED SILICONE JOINT SEALANT SHALL BE WATERTIGHT.  
 FOR POURABLE SILICONE JOINT SEALANT, SEE SPECIAL PROVISIONS.  
 THE CONTRACTOR SHALL NOT BE PERMITTED TO FORM THE JOINTS IN LIEU OF SAWING THE JOINTS.

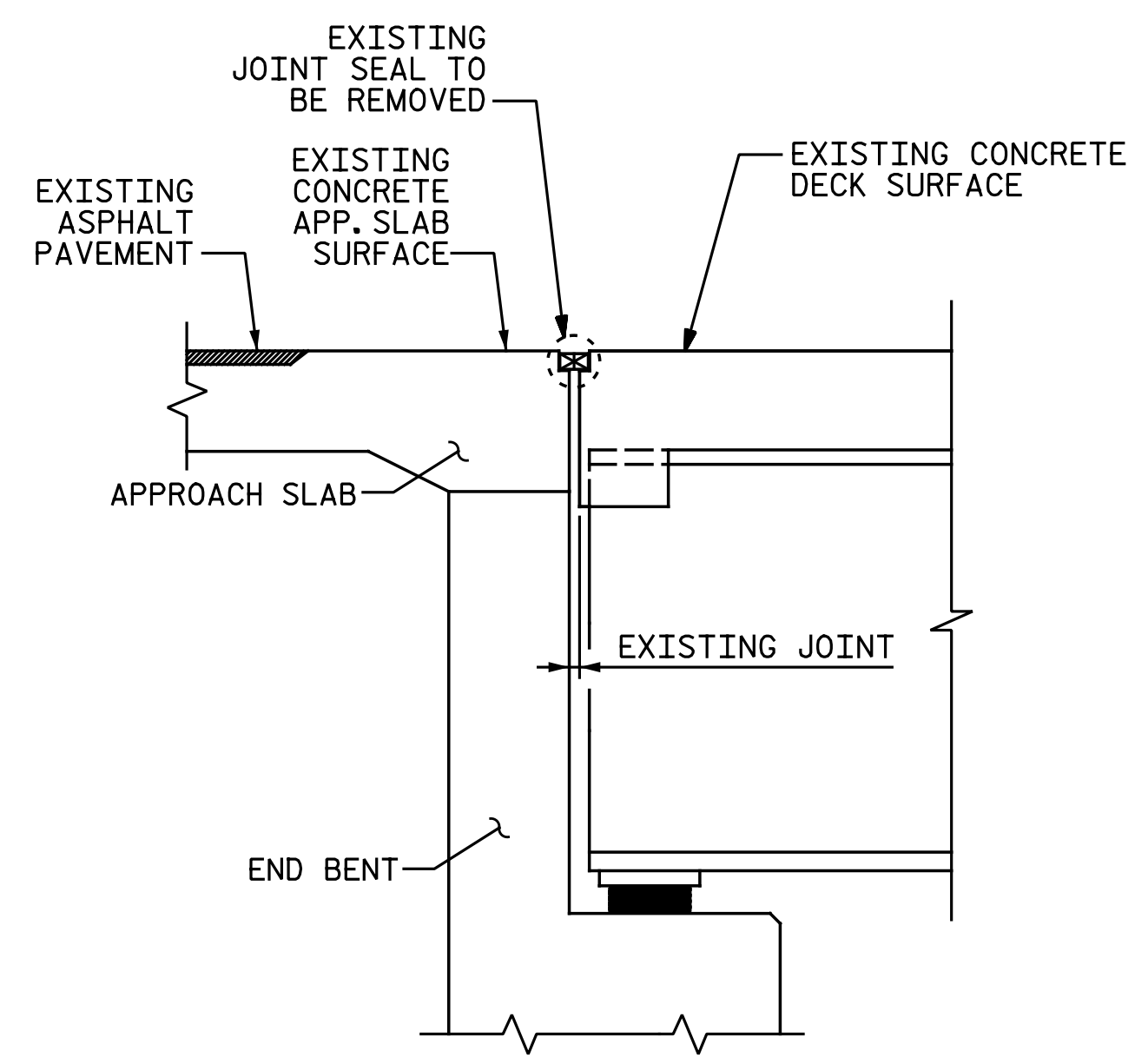

EXISTING JOINT

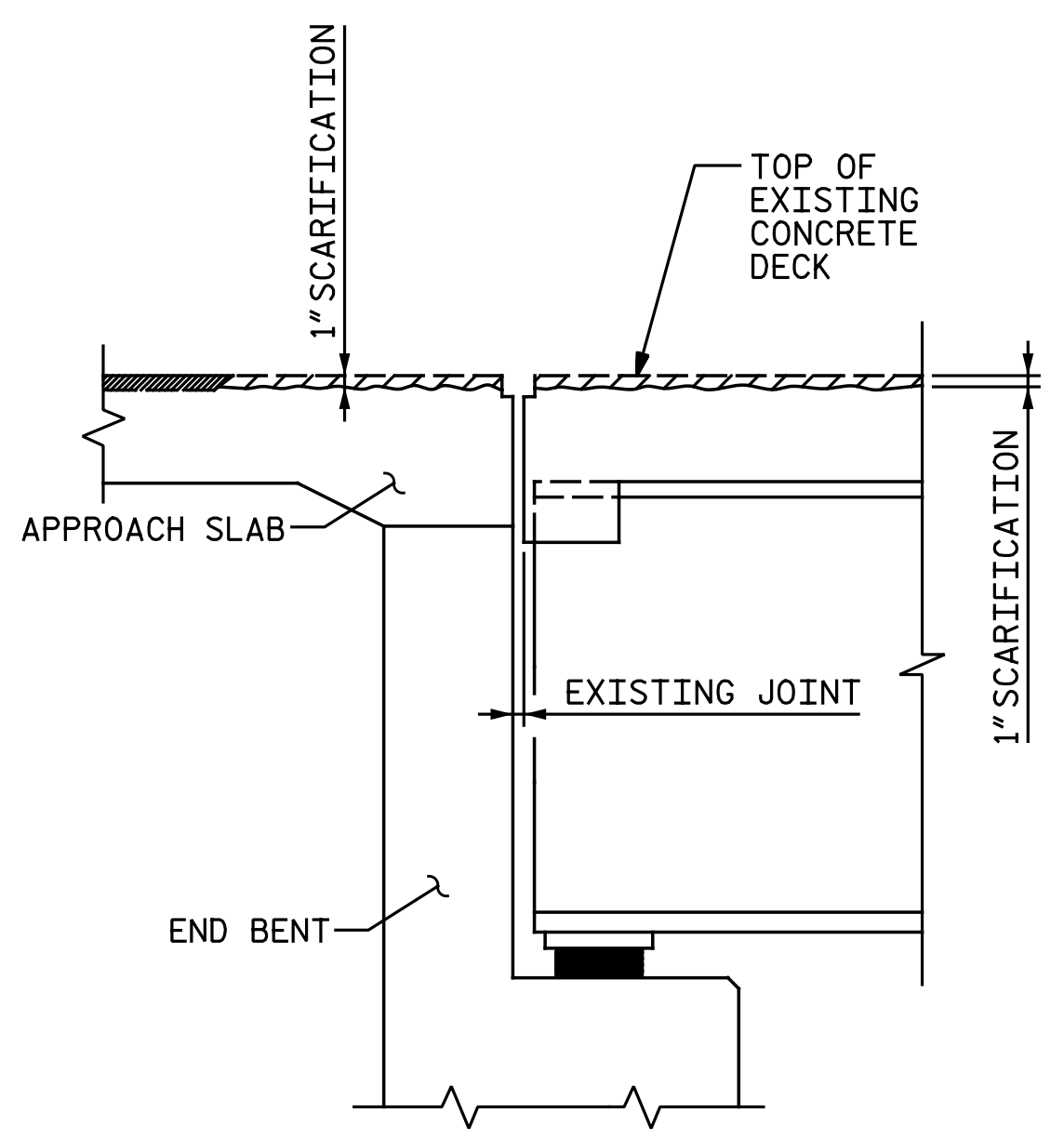

MINIMUM EXISTING JOINT REMOVAL & SCARIFICATION

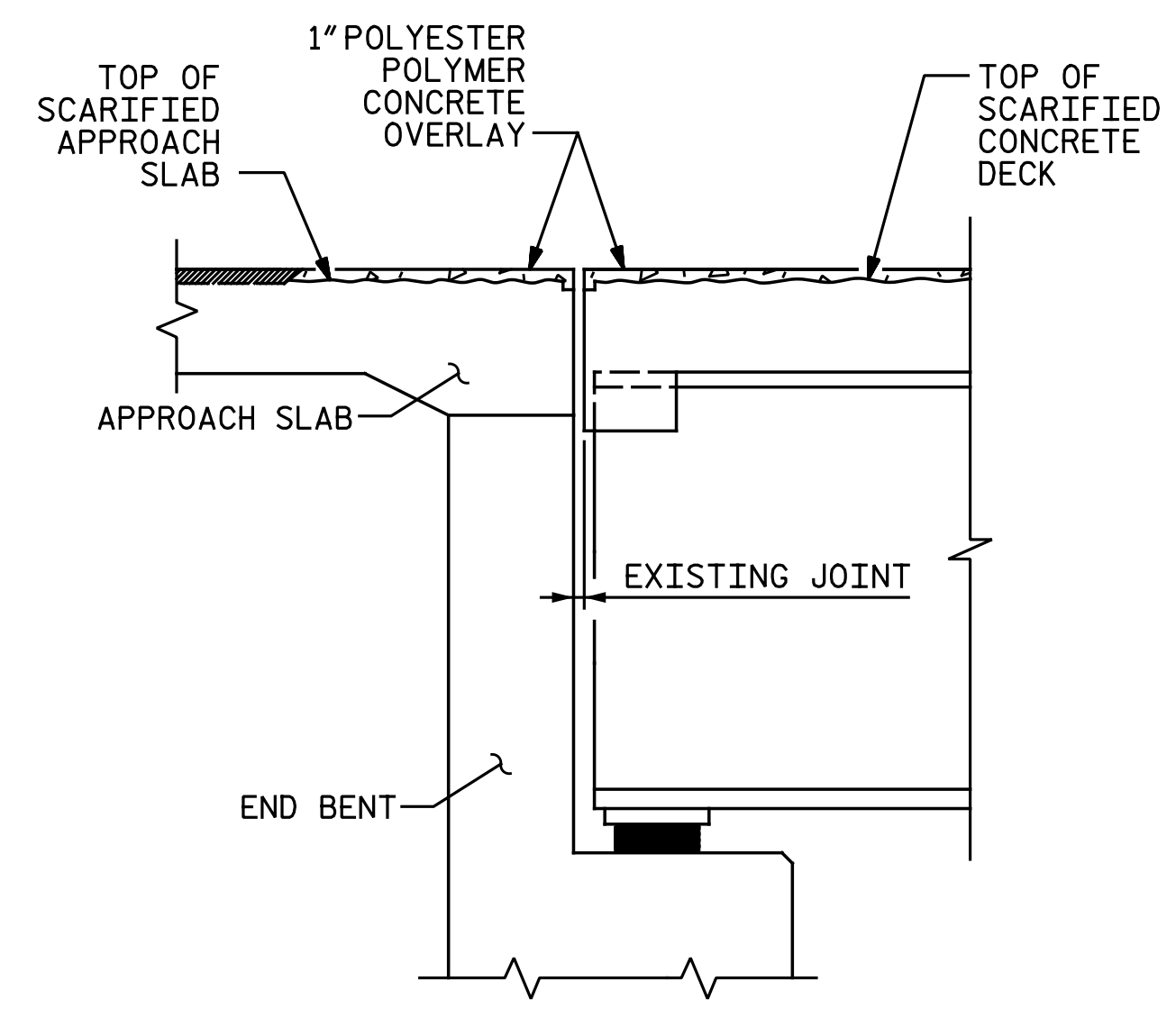

PROPOSED JOINT PRE-SAWED & POLYESTER POLYMER CONCRETE OVERLAY

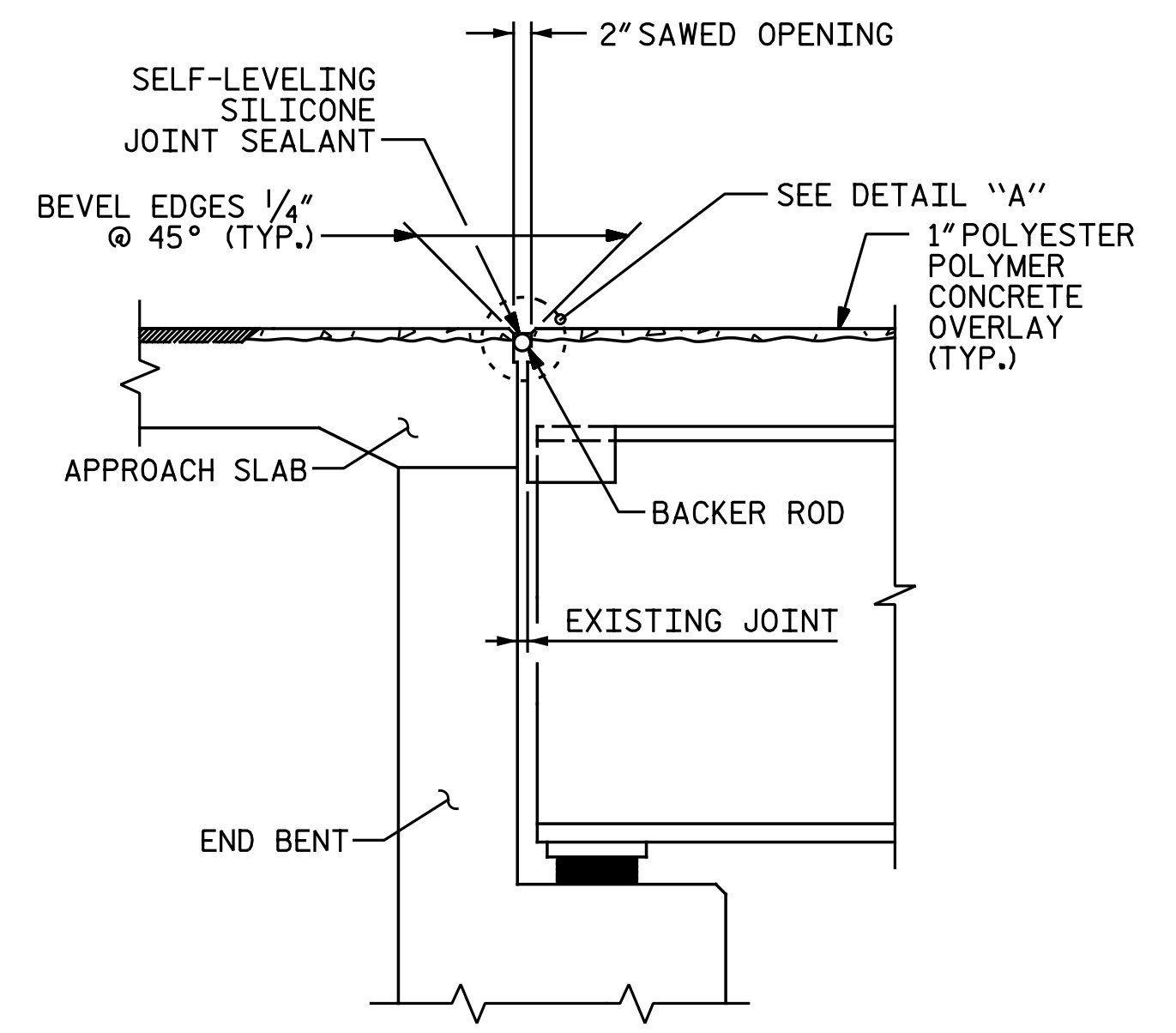

PROPOSED JOINT WITH SAWED DIMENSIONS

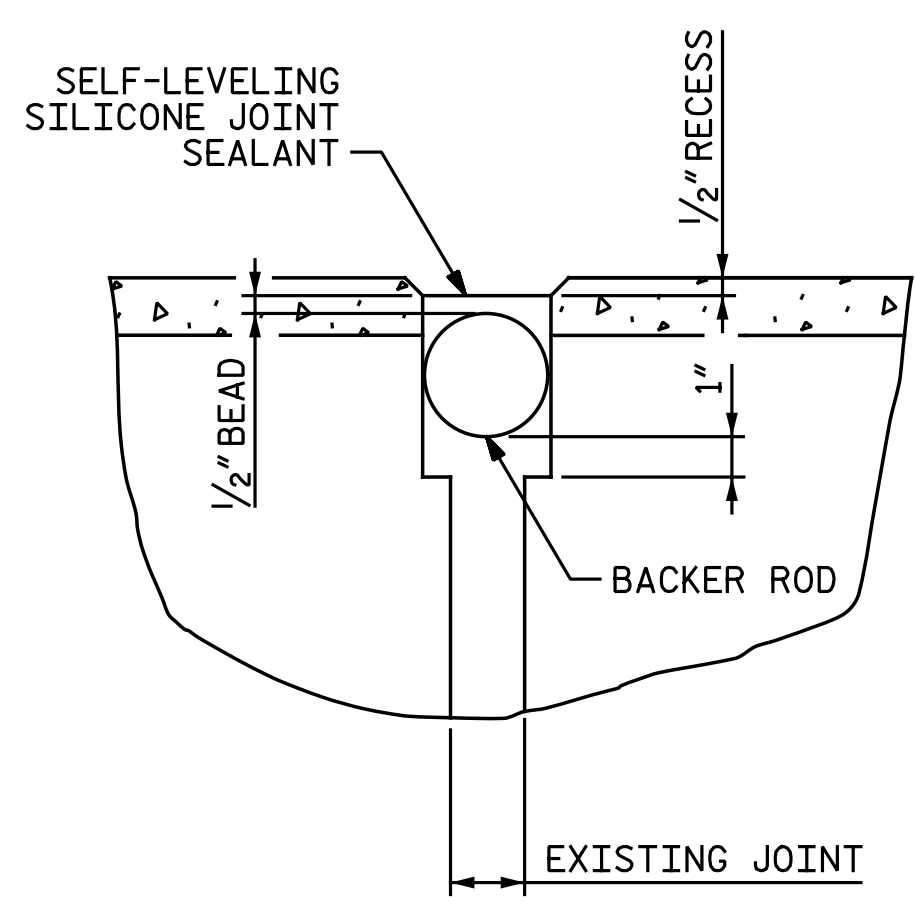

DETAIL "A"

PROJECT NO. I-5986B  
JOHNSTON COUNTY  
 STATION: 25+31.59 -Y18-

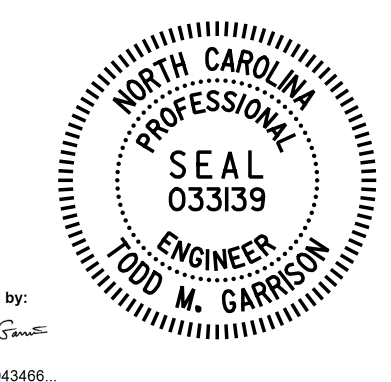

DocuSigned by:  
 Todd M. Garrison  
 61EAF7529A3466  
 4/27/2021

STATE OF NORTH CAROLINA  
 DEPARTMENT OF TRANSPORTATION  
 RALEIGH

**JOINT REPAIR DETAILS**

DOCUMENT NOT CONSIDERED FINAL  
 UNLESS ALL SIGNATURES COMPLETED

<b>Michael Baker INTERNATIONAL</b> Michael Baker Engineering 8000 Regency Parkway, Suite 600 Cary, North Carolina 27518 NC License No.: F-1084	REVISIONS						SHEET NO.
	NO.	BY:	DATE:	NO.	BY:	DATE:	S4-6
	1			3			TOTAL SHEETS
	2			4			14

DRAWN BY : N. B. SPEAKS DATE : 5-1-20  
 CHECKED BY : J. M. GARRISON DATE : 2-1-21