

NOTES:
 ALL REINFORCING STEEL IN SIDEWALKS SHALL BE EPOXY COATED.
 GROOVED CONTRACTION JOINTS, 1/2" IN DEPTH, SHALL BE TOOLED IN ALL EXPOSED FACES OF THE SIDEWALK IN ACCORDANCE WITH ARTICLE 825-10(B) OF THE STANDARD SPECIFICATIONS. THE CONTRACTION JOINTS SHALL BE LOCATED AT A SPACING OF 8 FEET TO 10 FEET BETWEEN EXPANSION JOINTS. NO CONTRACTION JOINT WILL BE REQUIRED FOR SEGMENTS LESS THAN 10 FEET IN LENGTH.
 THE #4 D1 AND D2 DOWELS SHALL BE INSTALLED USING AN ADHESIVE ANCHORING SYSTEM. FIELD TESTING IS NOT REQUIRED.

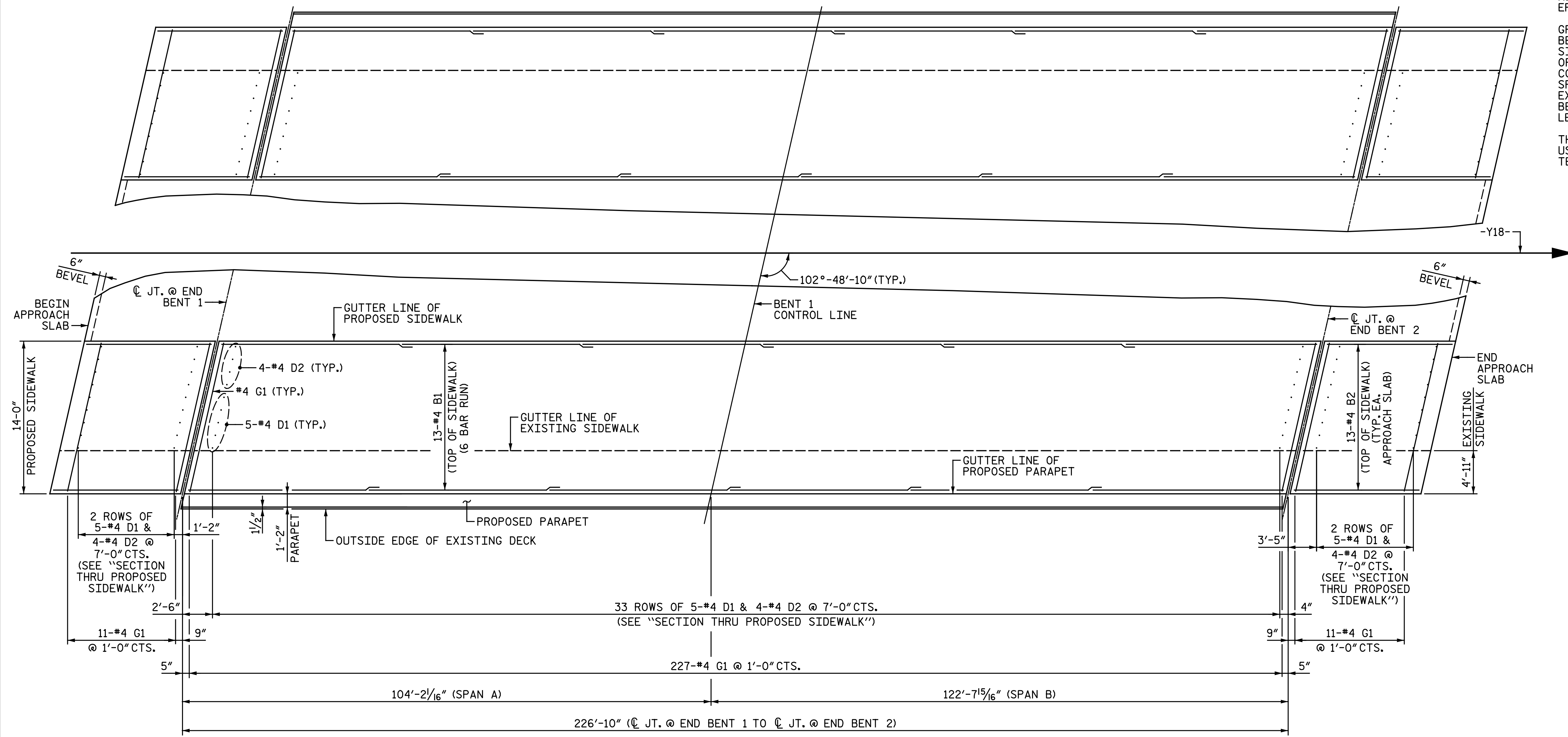

| SPLICE LENGTHS | | |
|----------------|--------------|----------|
| BAR SIZE | EPOXY COATED | UNCOATED |
| #4 | 2'-0" | - |

| BILL OF MATERIAL | | | | | |
|----------------------------------|-----|------|------|-----------|--------|
| PROPOSED SIDEWALKS | | | | | |
| BAR | NO. | SIZE | TYPE | LENGTH | WEIGHT |
| *B1 | 156 | #4 | STR. | 39' - 5" | 4,108 |
| *B2 | 52 | #4 | STR. | 11' - 7" | 402 |
| *D1 | 370 | #4 | STR. | 11" | 227 |
| *D2 | 296 | #4 | STR. | 9" | 148 |
| *G1 | 498 | #4 | STR. | 13' - 10" | 4,602 |
| * EPOXY COATED REINFORCING STEEL | | | | LBS. | 9,487 |
| CLASS AA CONCRETE | | | | CU. YDS. | 205.7 |

PLAN OF PROPOSED SIDEWALK
 DETAILS FOR RIGHT SIDEWALK SHOWN, DETAILS FOR LEFT SIDEWALK SIMILAR.

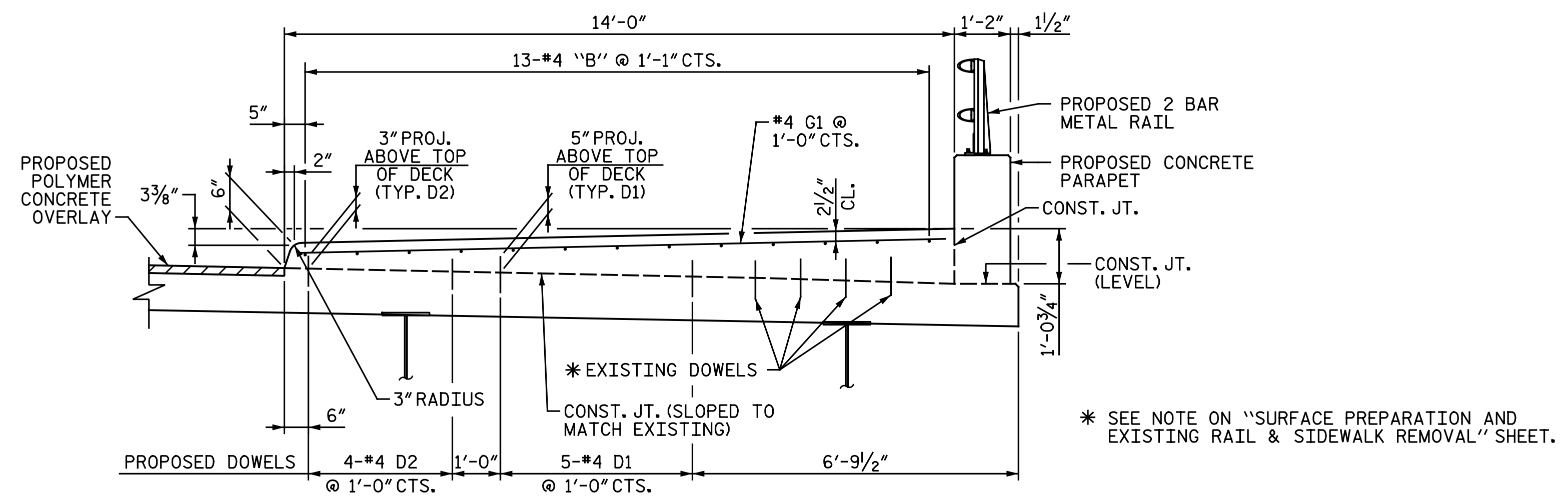

SECTION THRU PROPOSED SIDEWALK

RIGHT SIDEWALK SHOWN, LEFT SIDEWALK SIMILAR.
 SIDEWALK ON BRIDGE SHOWN INCLUDING PARAPET AND 2 BAR METAL RAIL, SIDEWALKS ON APPROACH SLABS SIMILAR EXCLUDING PARAPETS AND 2 BAR METAL RAILS.

PROJECT NO. I-5986B
JOHNSTON COUNTY
 STATION: 25+31.59 -Y18-
 SHEET 1 OF 2

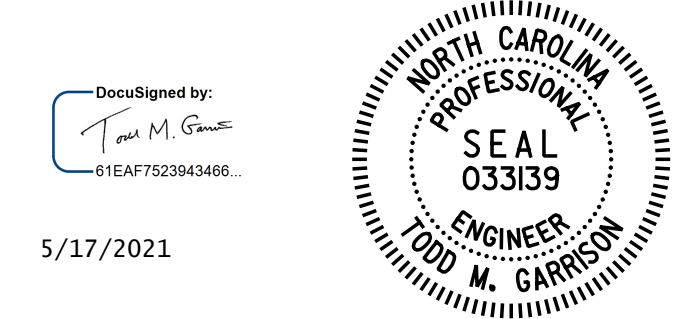

STATE OF NORTH CAROLINA
 DEPARTMENT OF TRANSPORTATION
 RALEIGH
SIDEWALK DETAILS

DOCUMENT NOT CONSIDERED FINAL
 UNLESS ALL SIGNATURES COMPLETED

| REVISIONS | | | | | | SHEET NO. |
|-----------|-----|-------|-----|-----|-------|--------------|
| NO. | BY: | DATE: | NO. | BY: | DATE: | S4-13 |
| 1 | | | 3 | | | TOTAL SHEETS |
| 2 | | | 4 | | | 14 |

DRAWN BY : C. E. MAYHEW DATE : 5-12-21
 CHECKED BY : J. M. GARRISON DATE : 5-12-21

Michael Baker INTERNATIONAL
 Michael Baker Engineering
 8000 Regency Parkway, Suite 600
 Cary, North Carolina 27518
 NC License No.: F-1084