

NOTES:

UNLESS NOTED OTHERWISE RETAIN ALL EXISTING REINFORCING STEEL. CLEAN AND REPAIR AS NEEDED.

SILICONE JOINT SEALANT AND BACKER ROD SHALL BE INSTALLED AS PER MANUFACTURER'S RECOMMENDATION.

THE INSTALLED SILICONE JOINT SEALANT SHALL BE WATERTIGHT.

FOR POURABLE SILICONE JOINT SEALANT, SEE SPECIAL PROVISIONS.

THE CONTRACTOR SHALL NOT BE PERMITTED TO FORM THE JOINTS IN LIEU OF SAWING THE JOINTS.

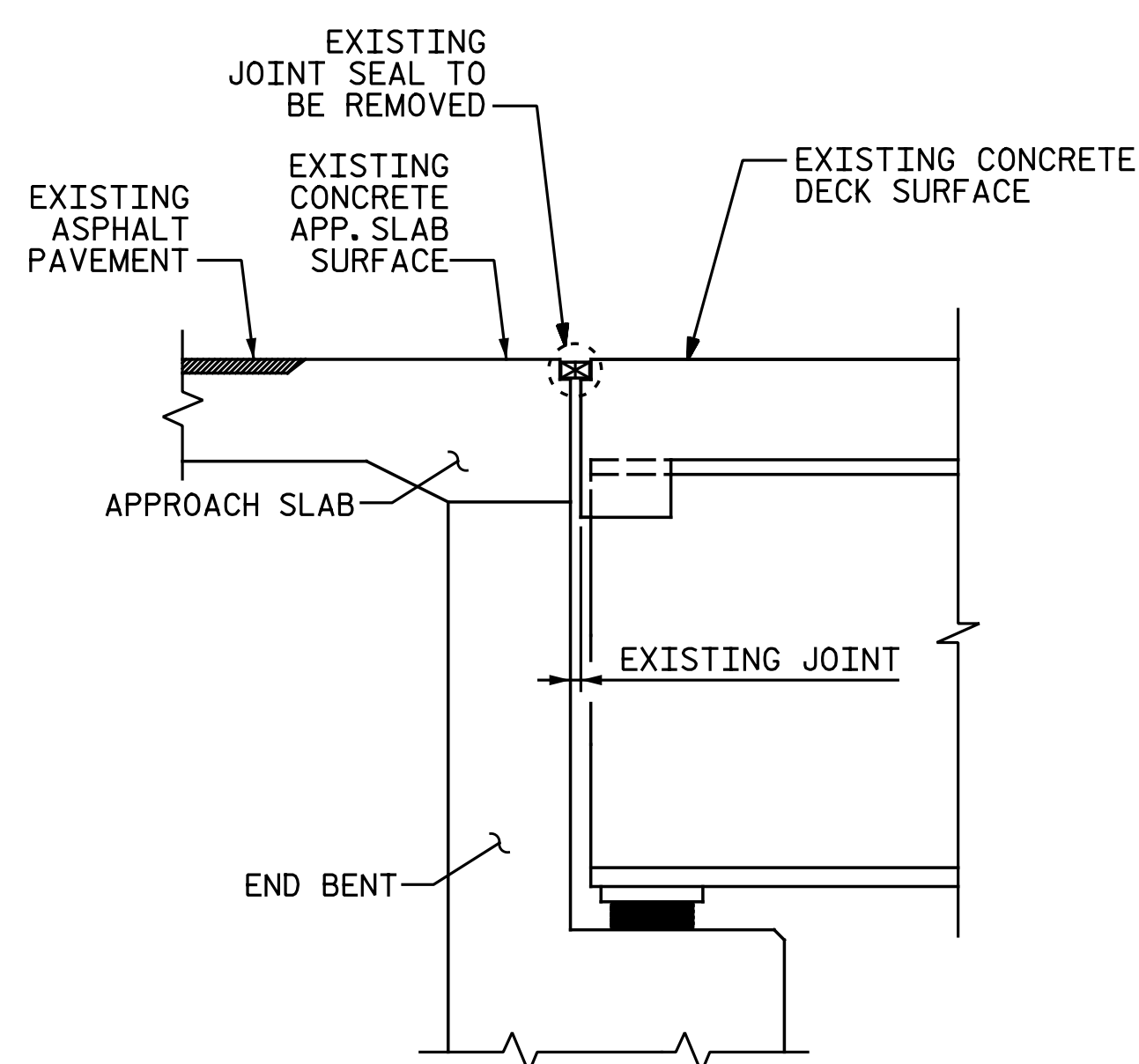

EXISTING JOINT

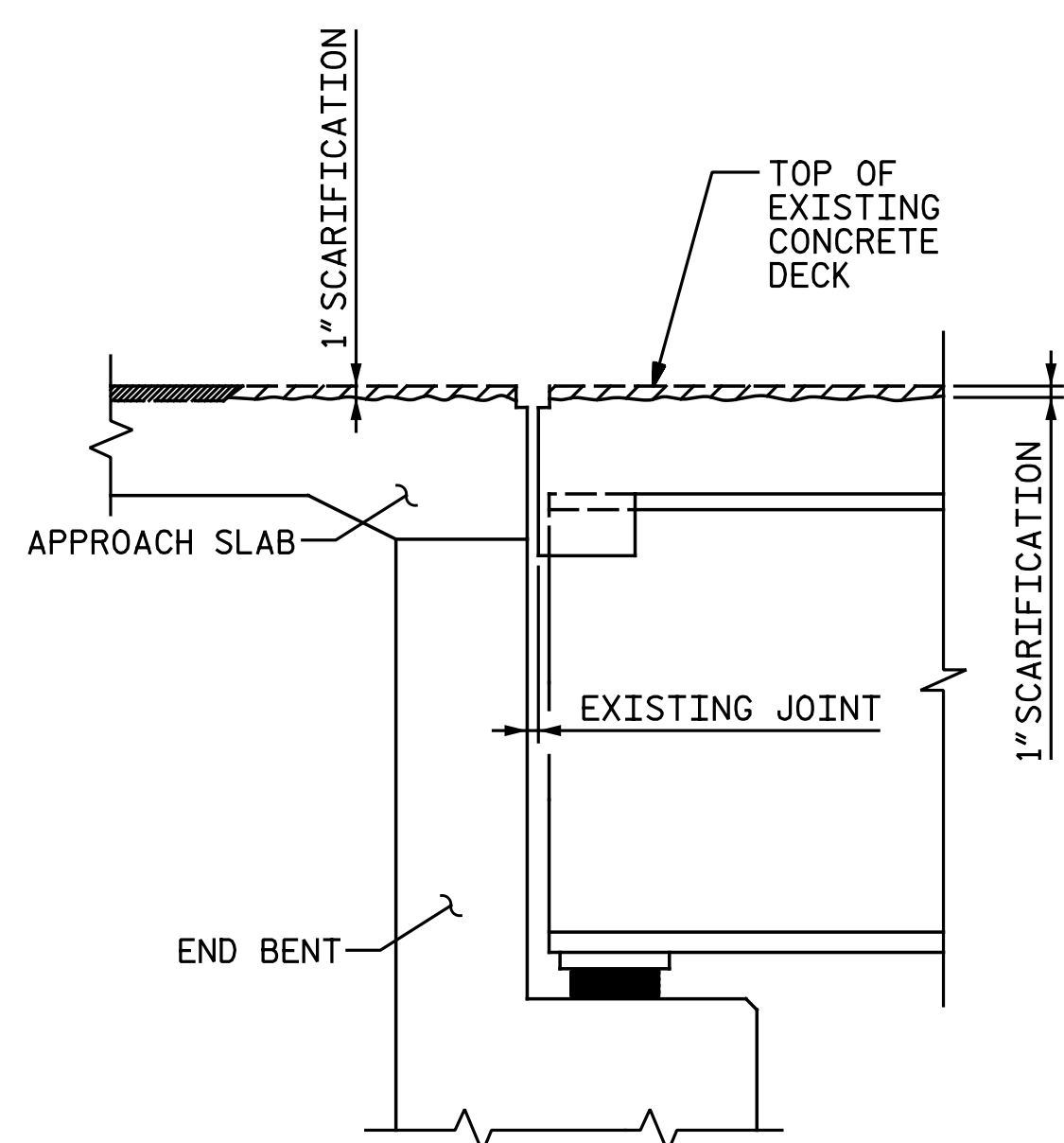

MINIMUM EXISTING JOINT REMOVAL & SCARIFICATION

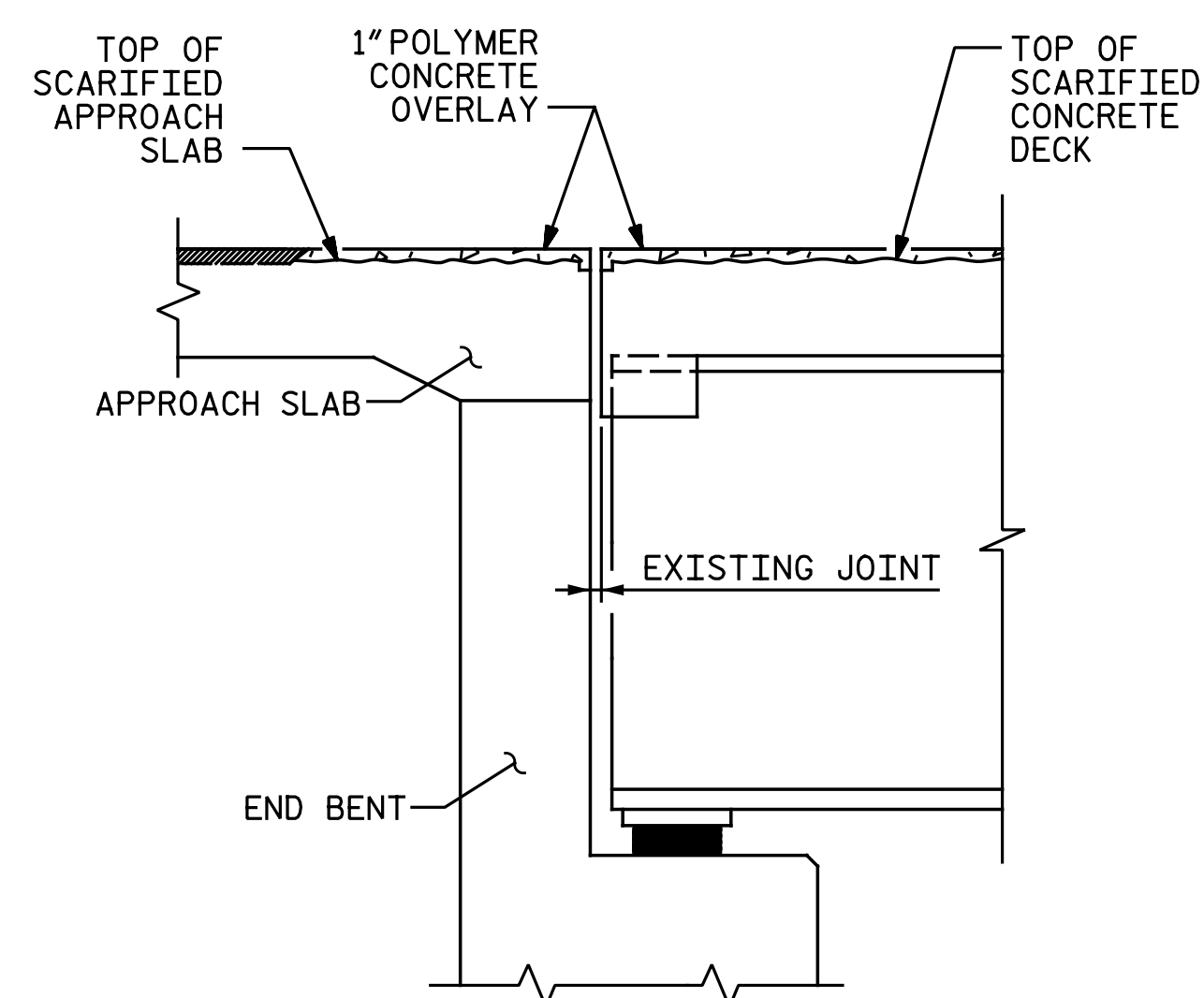

PROPOSED JOINT PRE-SAWED & POLYMER CONCRETE OVERLAY

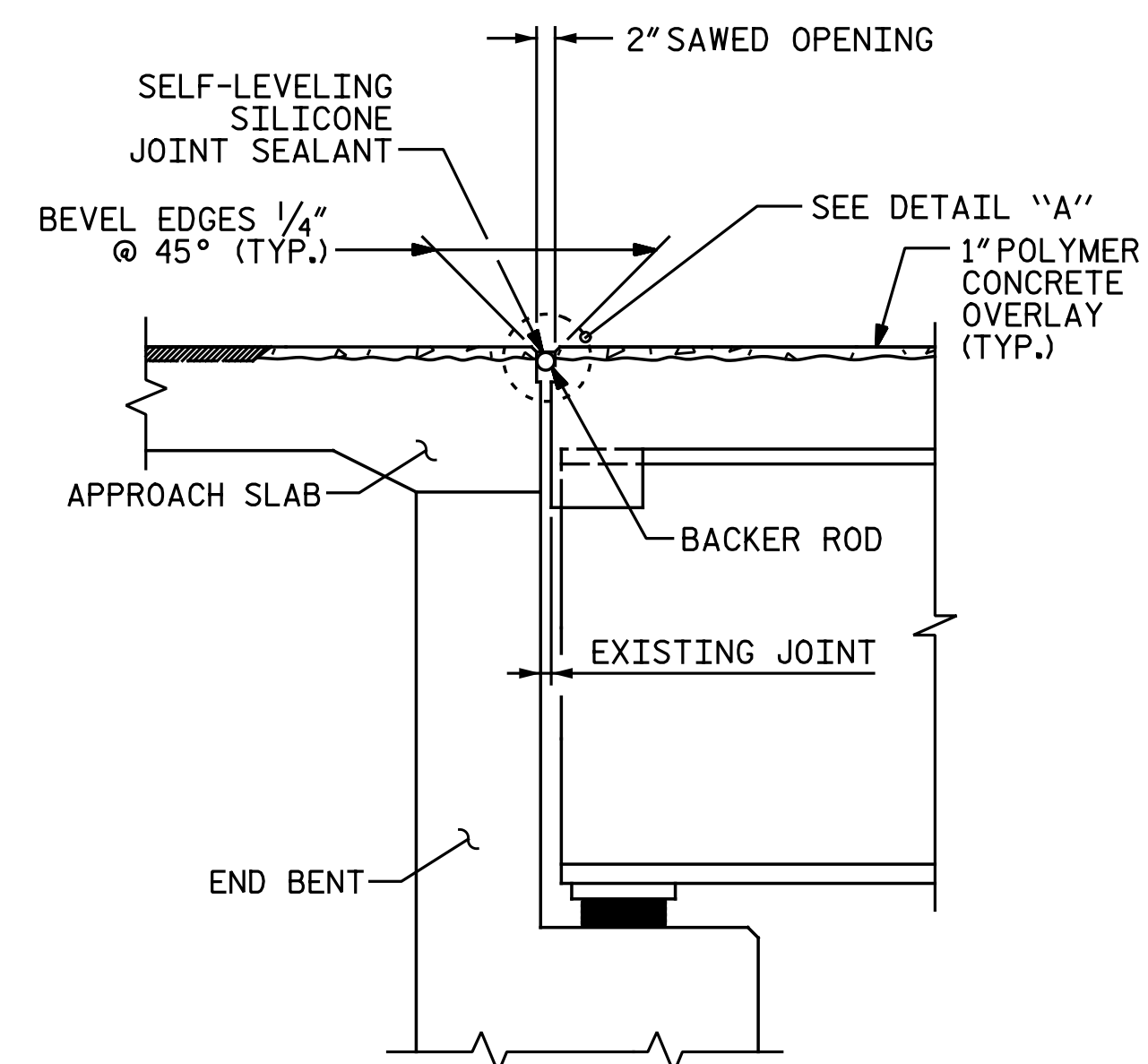

PROPOSED JOINT WITH SAWED DIMENSIONS

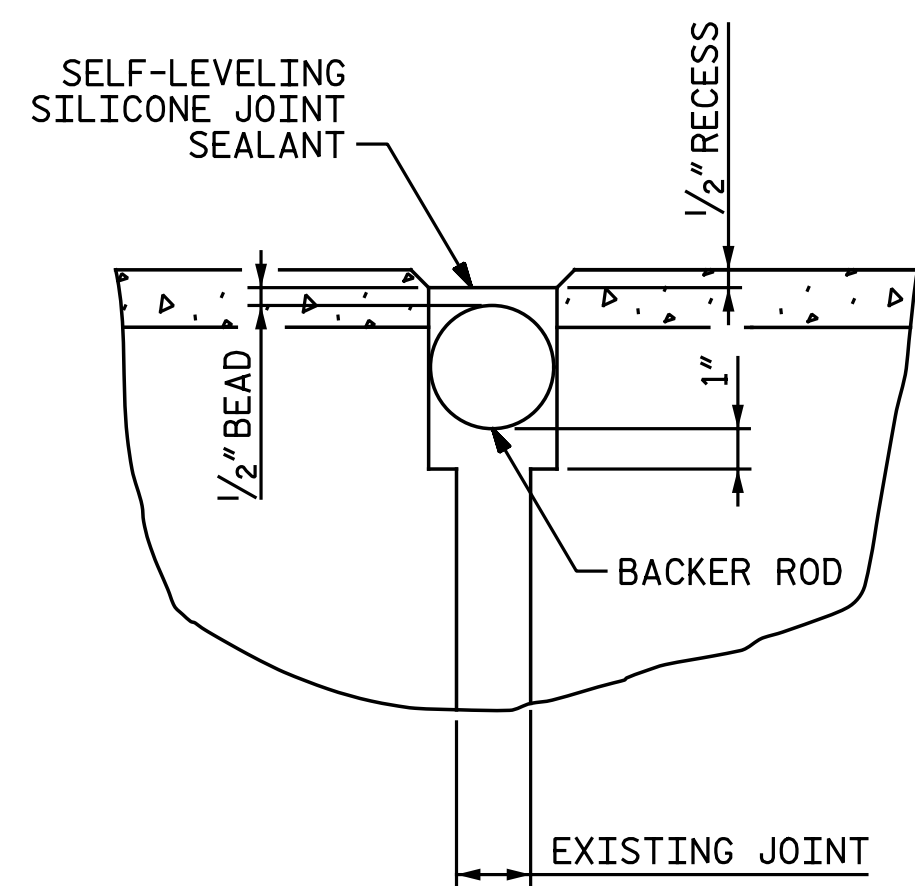

DETAIL "A"

PROJECT NO. I-5986B
JOHNSTON COUNTY
 STATION: 25+31.59 -Y18-

DocuSigned by:
 Todd M. Garrison
 01EAF7523943466
 5/17/2021



STATE OF NORTH CAROLINA
 DEPARTMENT OF TRANSPORTATION
 RALEIGH

 JOINT REPAIR
 DETAILS

DOCUMENT NOT CONSIDERED FINAL
 UNLESS ALL SIGNATURES COMPLETED

DRAWN BY : N. B. SPEAKS DATE : 5-12-21
 CHECKED BY : I. M. GARRISON DATE : 5-12-21

REVISIONS						SHEET NO.
NO.	BY:	DATE:	NO.	BY:	DATE:	S4-6
1			3			TOTAL SHEETS
2			4			14

Michael Baker INTERNATIONAL
 Michael Baker Engineering
 8000 Regency Parkway, Suite 600
 Cary, North Carolina 27518
 NC License No.: F-1084