

**NOTE:**

FOR MAINTENANCE OF TRAFFIC, REMOVAL OF EXISTING PAVEMENT, AND LOCATIONS OF TEMPORARY SHORING, TEMPORARY PAVEMENT, AND PORTABLE CONCRETE BARRIERS, SEE TRAFFIC CONTROL PLANS.

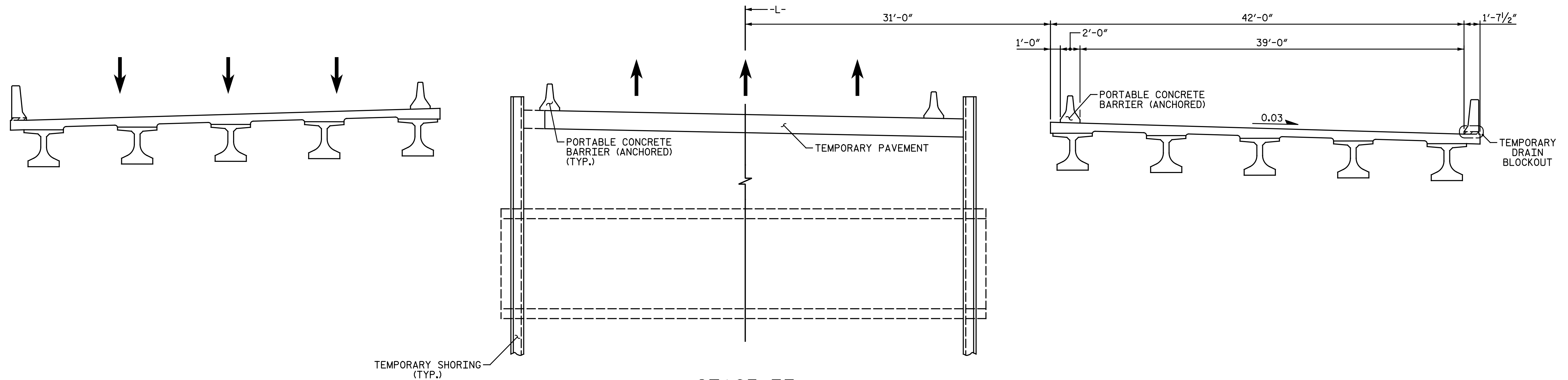

**STAGE II**

MOVE NORTHBOUND TRAFFIC INTO I-95 MEDIAN SECTION AND SOUTHBOUND TRAFFIC ONTO STAGE I.  
REMOVE PORTION OF EXISTING CULVERT BEHIND TEMPORARY SHORING ON RIGHT SIDE OF I-95.  
CONSTRUCT RIGHT SIDE OF PROPOSED BRIDGE.

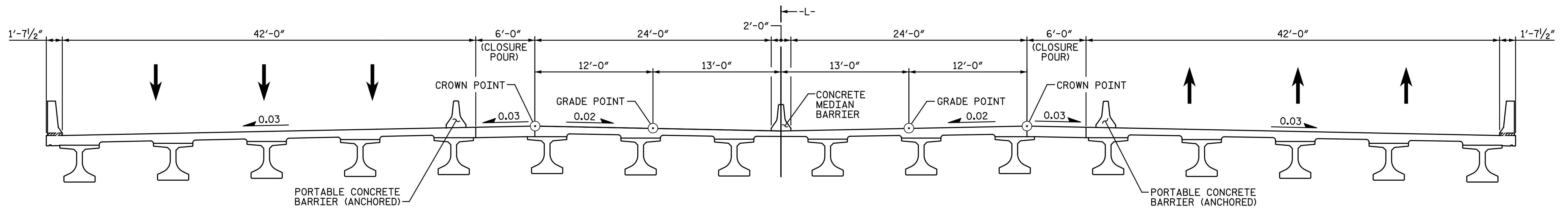

**STAGE III**

MOVE NORTHBOUND TRAFFIC ONTO STAGE II.  
REMOVE REMAINING PORTION OF EXISTING CULVERT.  
CONSTRUCT CENTER PORTION OF PROPOSED BRIDGE, INCLUDING CLOSURE POURS AND CONCRETE MEDIAN BARRIER.

PROJECT NO. I-5986B  
JOHNSTON COUNTY  
STATION: 1391+19.65 -L-

SHEET 2 OF 3

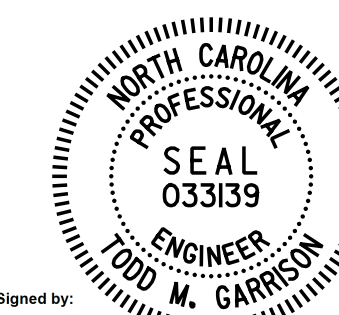

DocuSigned by:  
Todd M. Garrison  
01EAF7523943466  
4/30/2020

STATE OF NORTH CAROLINA  
DEPARTMENT OF TRANSPORTATION  
RALEIGH

**CONSTRUCTION SEQUENCE**

DOCUMENT NOT CONSIDERED FINAL  
UNLESS ALL SIGNATURES COMPLETED

**Michael Baker INTERNATIONAL**  
Michael Baker Engineering  
8000 Regency Parkway, Suite 600  
Cary, North Carolina 27518  
NC License No.: F-1084

REVISIONS						SHEET NO.
NO.	BY:	DATE:	NO.	BY:	DATE:	S3-7
1			3			TOTAL SHEETS
2			4			44

DRAWN BY : N. B. SPEAKS DATE : 8-19-19  
CHECKED BY : J. M. GARRISON DATE : 11-11-19