

NOTES:
 FOR ADDITIONAL NOTES, SEE "BENTS 1 & 2 STAGE I (LEFT SIDE)" SHEET.

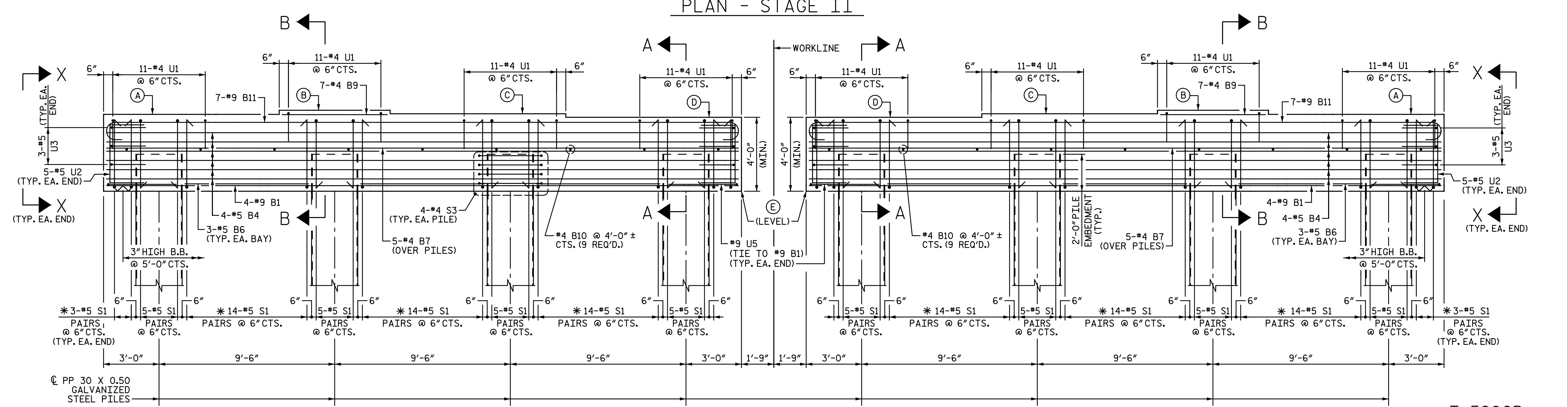
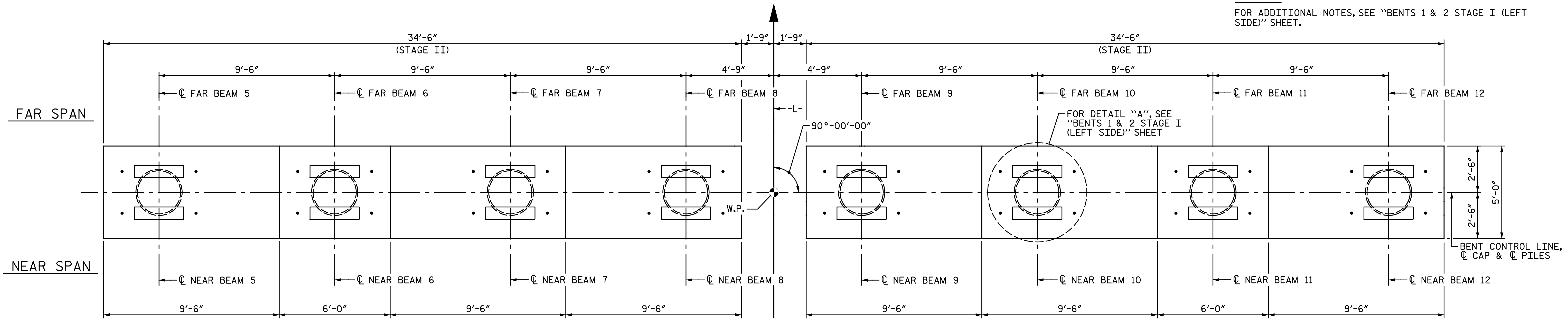

BENT	W.P.	NEAR SPAN	FAR SPAN
1	#2	A	B
2	#3	B	C

BENT CAP ELEVATIONS					
BENT	(A)	(B)	(C)	(D)	(E)
1	199.78	200.00	199.81	199.62	195.62
2	199.47	199.69	199.50	199.31	195.31

PROJECT NO. I-5986B
JOHNSTON COUNTY
 STATION: 1260+34.00 -L-

SHEET 3 OF 4
 STATE OF NORTH CAROLINA
 DEPARTMENT OF TRANSPORTATION
 RALEIGH
 SUBSTRUCTURE
 BENTS 1 & 2
 STAGE II

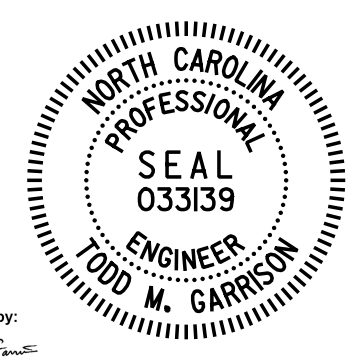

DocuSigned by:
 Todd M. Garrison
 4/9/2020

DOCUMENT NOT CONSIDERED FINAL
 UNLESS ALL SIGNATURES COMPLETED

Michael Baker International
 Michael Baker Engineering
 8000 Regency Parkway, Suite 600
 Cary, North Carolina 27518
 NC License No.: F-1084

REVISIONS						SHEET NO.
NO.	BY:	DATE:	NO.	BY:	DATE:	SI-45
1			3			TOTAL SHEETS
2			4			57

DRAWN BY: C. E. MAYHEW DATE: 2-3-20
 CHECKED BY: J. M. GARRISON DATE: 2-5-20