

Note:
1. Opening in pole base plate shall be equal to pole base inside diameter minus 3 1/2" but shall not be less than 8 1/2".

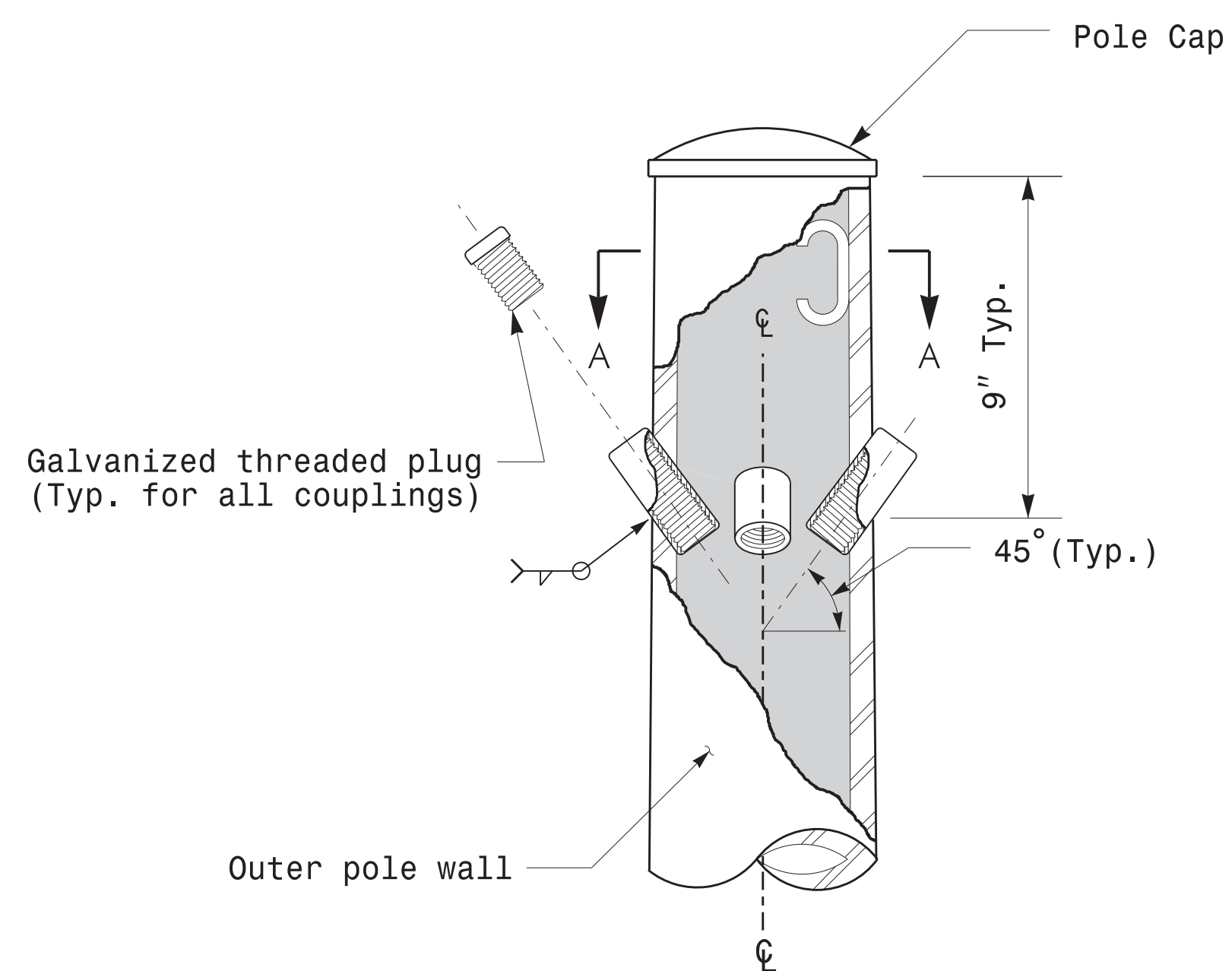

Cable Entrances at Top of Pole

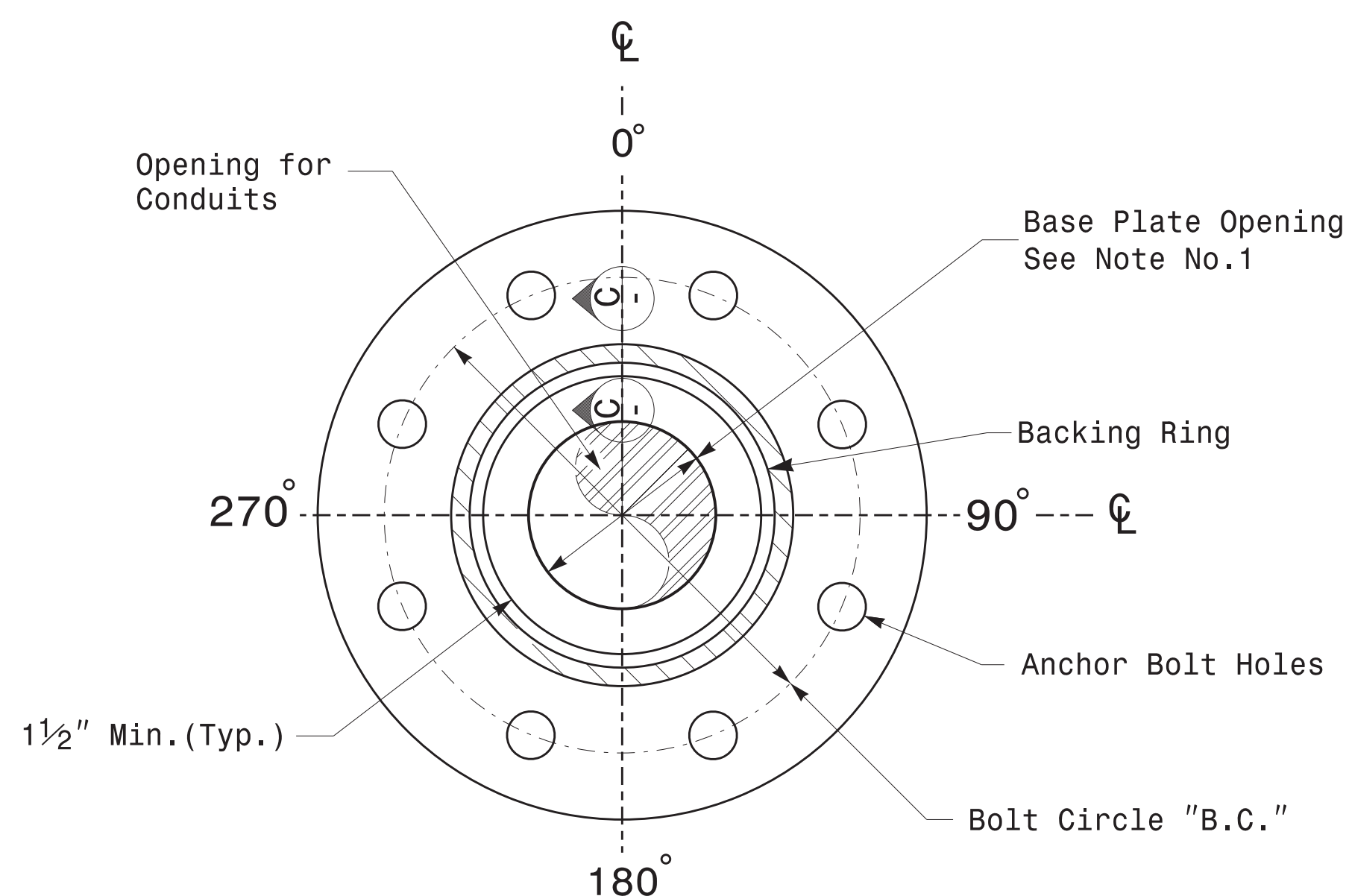

Section B-B
Pole Base Plate Details
(8 and 12 Bolt Pattern)

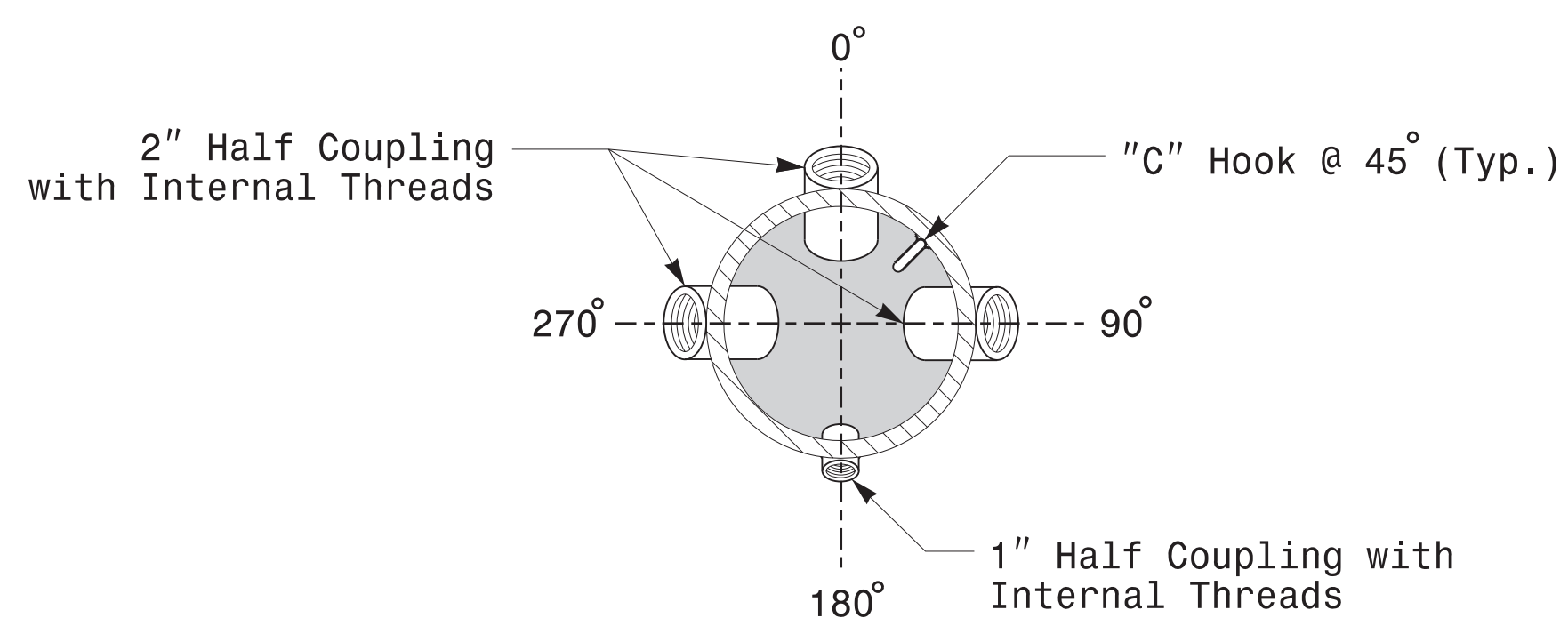

Section A-A
Radial Orientation for Factory Installed
Accessories at Top of Pole

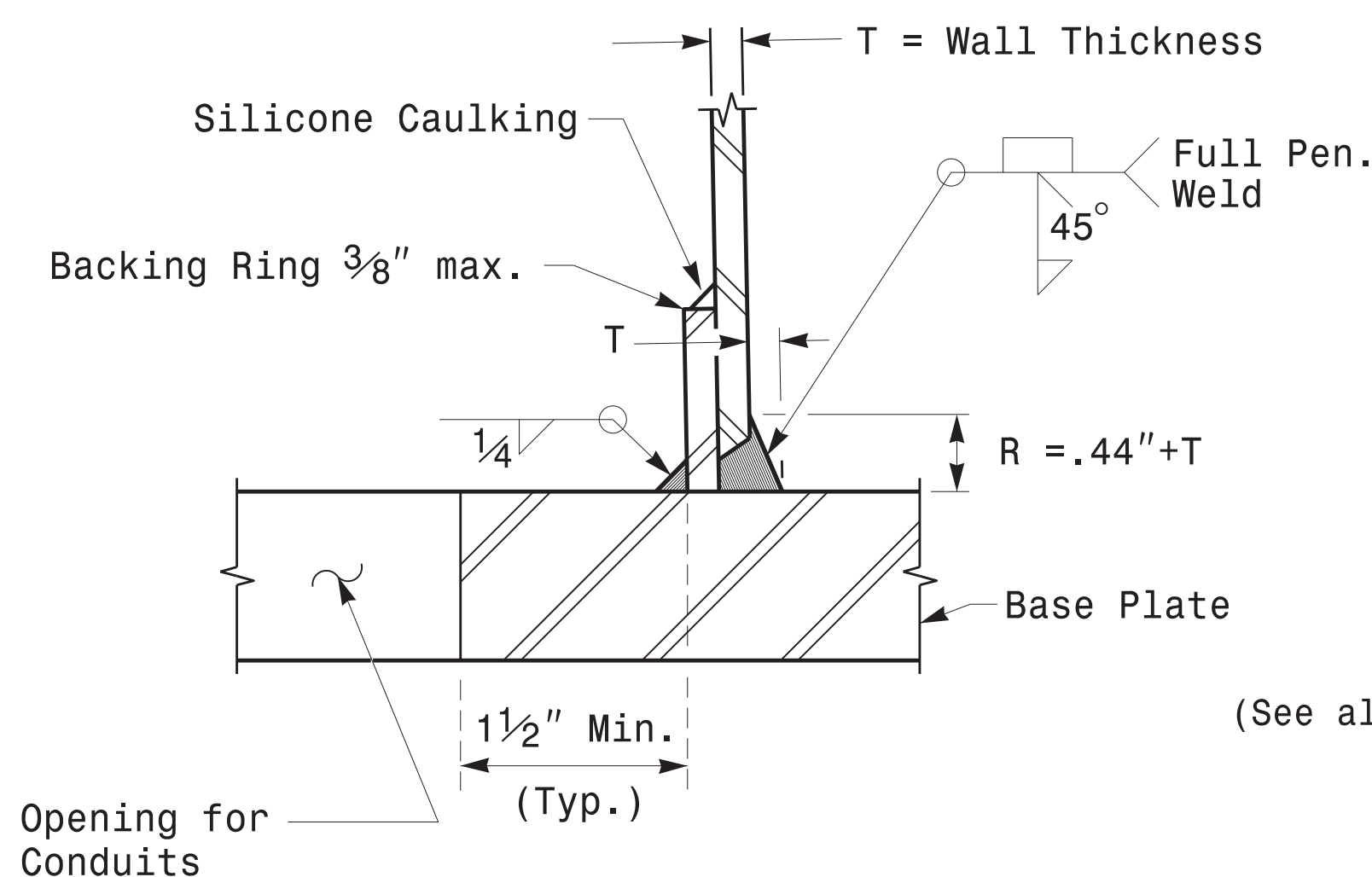

Section C-C
(Pole Attachment to Base Plate)
Full-Penetration
Groove Weld Detail

2 Cable Clamps designed for variable attachment heights from 1'-6" to 5'-0" below the top of the pole.

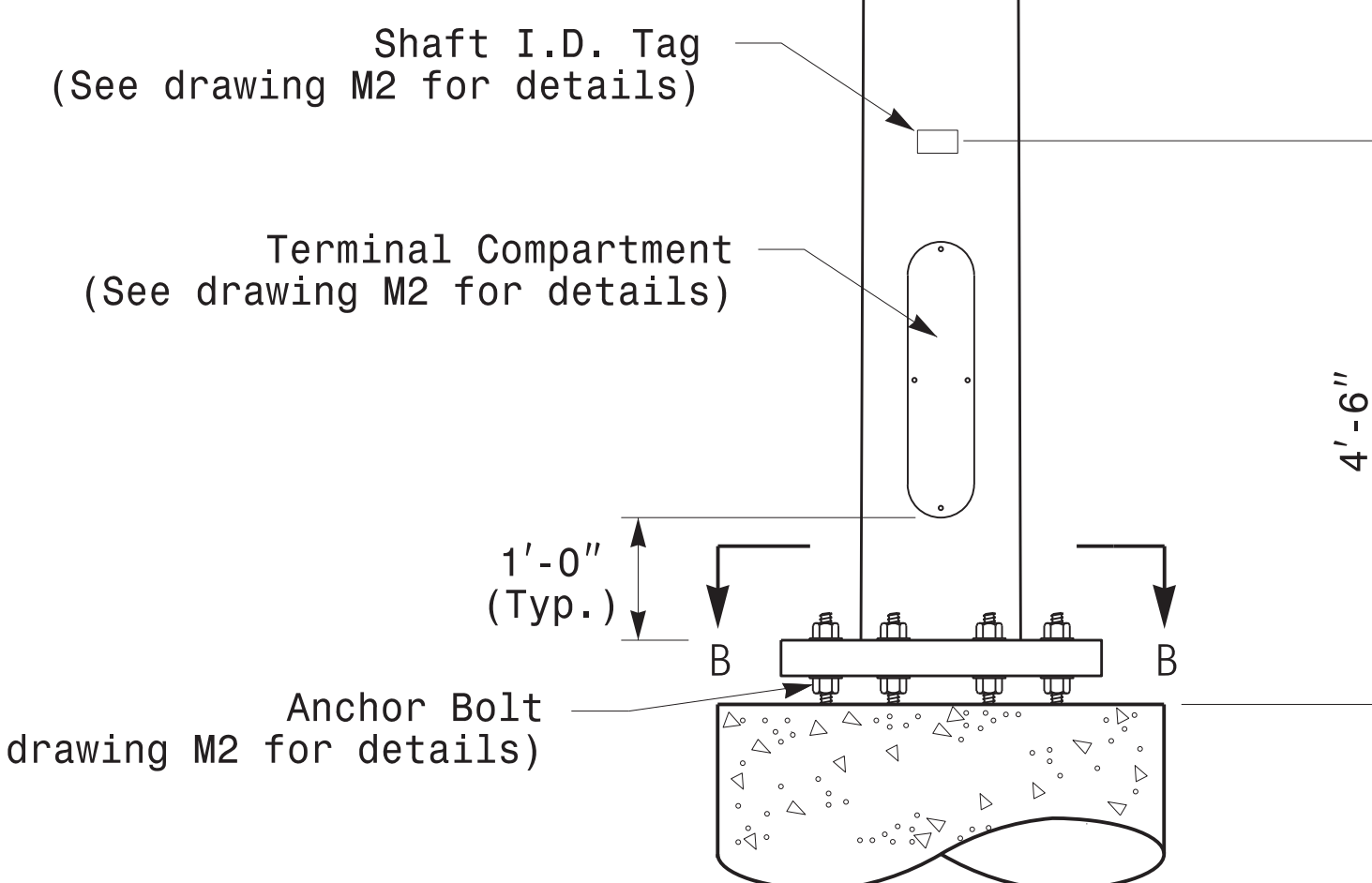

Monotube Strain Pole

Prepared in the Offices of:

750 N. Greenleaf Hwy, Garner, NC 27529

SCALE: 0 NA NONE

Typical Fabrication Details For Strain Poles			
PLAN DATE:	OCTOBER 2017	DESIGNED BY:	K.C. DURIGON
PREPARED BY:	N. BITTING	REVIEWED BY:	D.C. SARKAR
REVISIONS	INIT.	DATE	

SEAL

DocuSigned by: Debesh C. Sarkar

44EB82E147E4C4... DATE: 10/11/2017

Fabrication Details – Strain Poles

11-0CT-2017-08:25 136504115 Signal&Sigs Design Section Eastern Region\\M3 Sheets\\2016\\2014 Sig.M3 Std. Fabrication Details-Strain Poles.dgn