

PROJECT REFERENCE NO.	SHEET NO.
1-5883	2D-4
RW DESIGN NO.	
ROADWAY DESIGN ENGINEER	HYDRAULICS ENGINEER
DOCUMENT NOT CONSIDERED FINAL UNLESS ALL SIGNATURES COMPLETED	

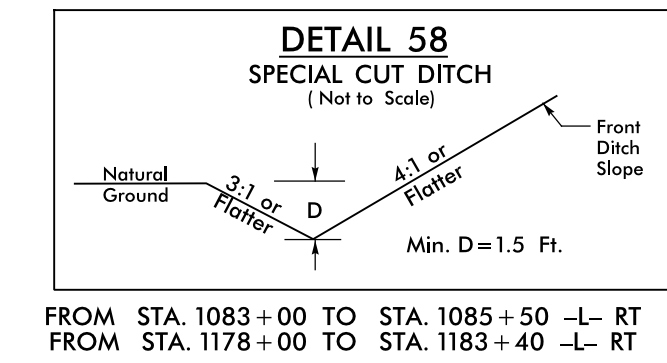
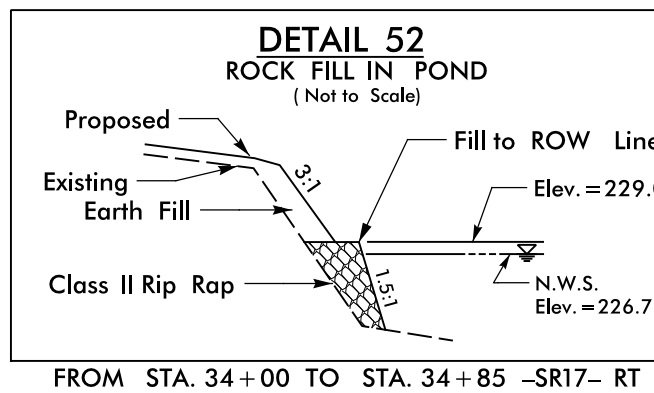
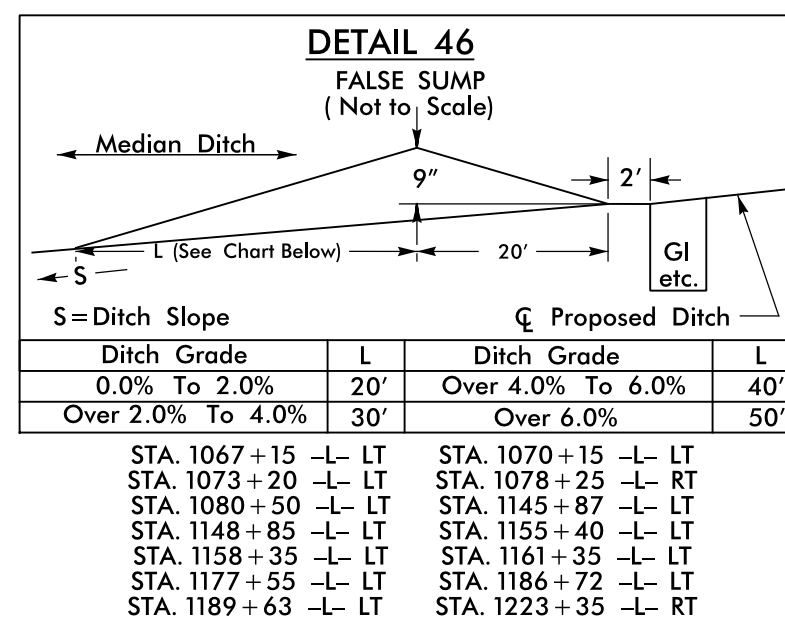
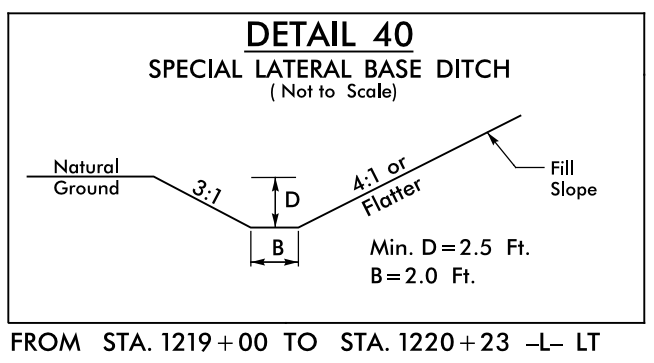
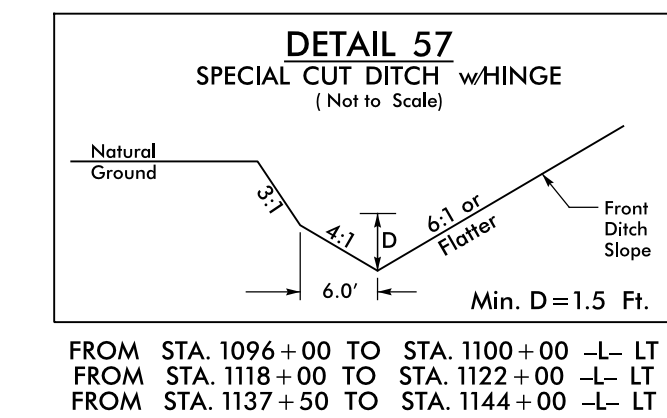
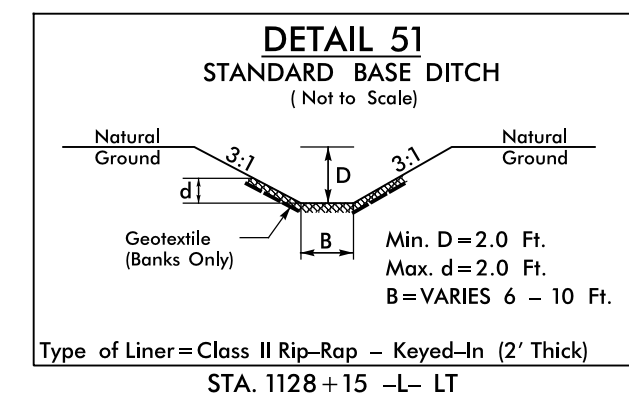
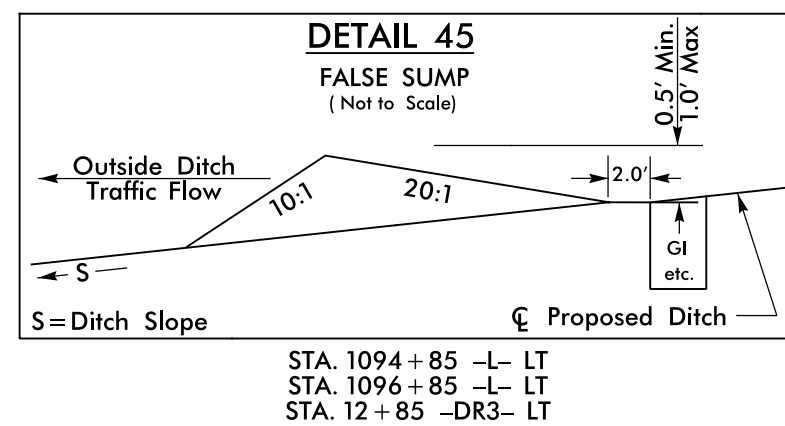
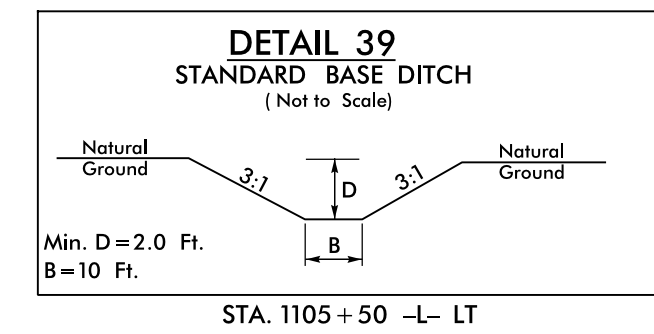
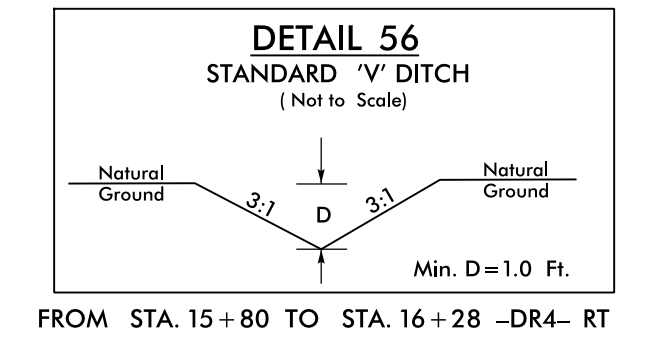
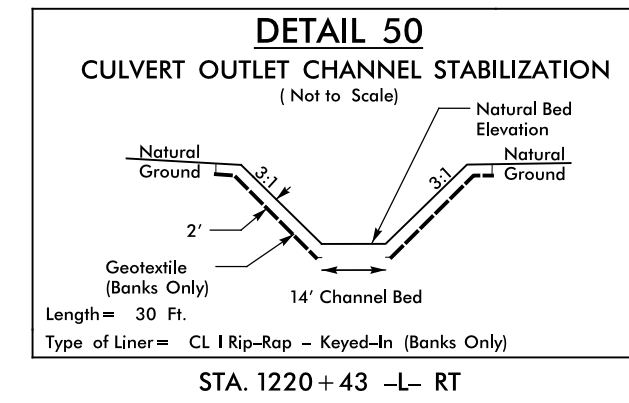
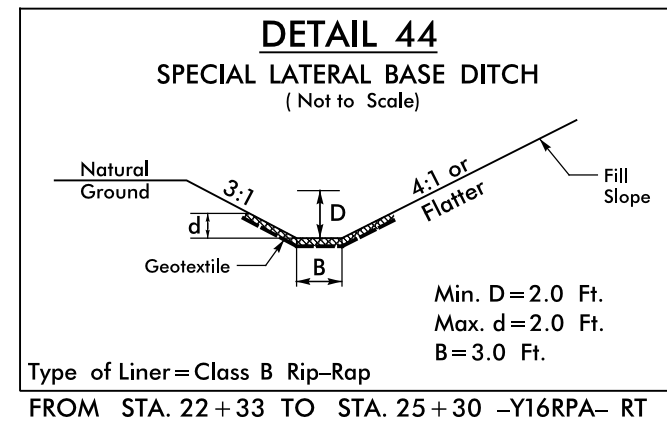
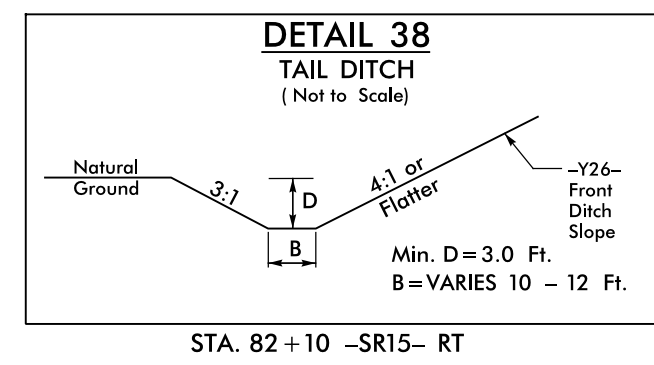
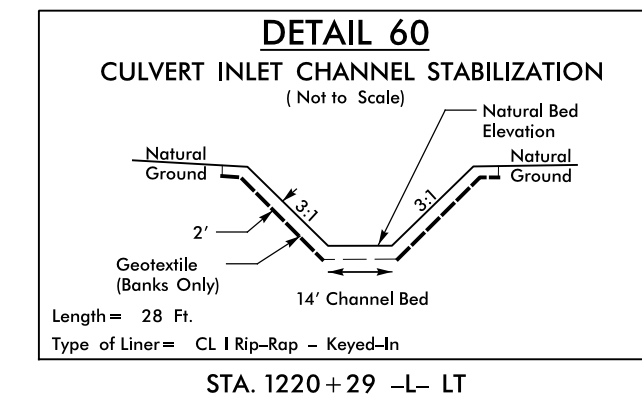
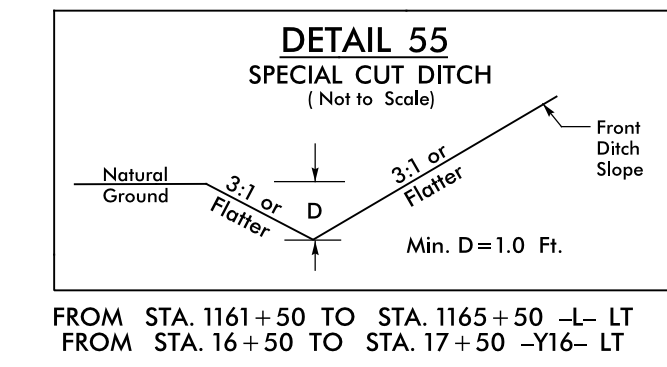
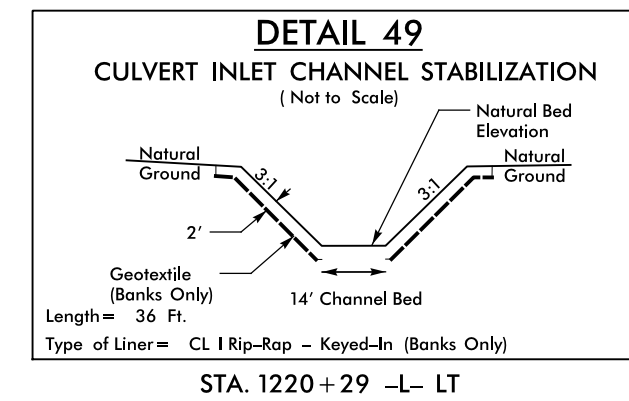
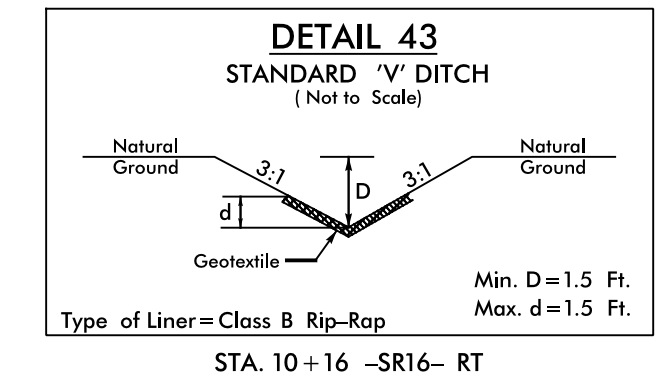
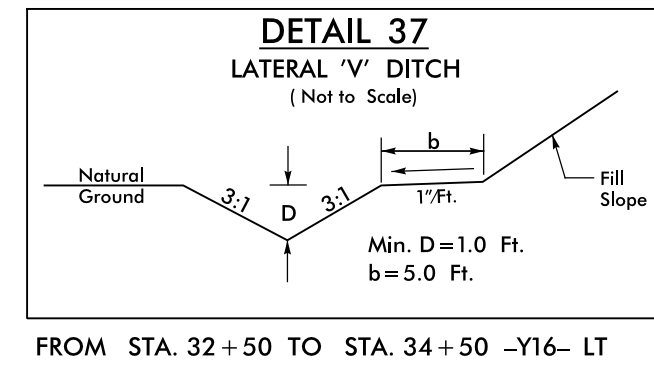
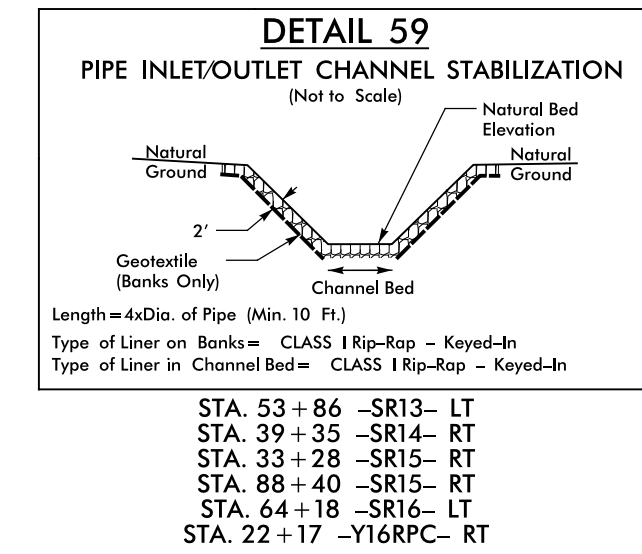
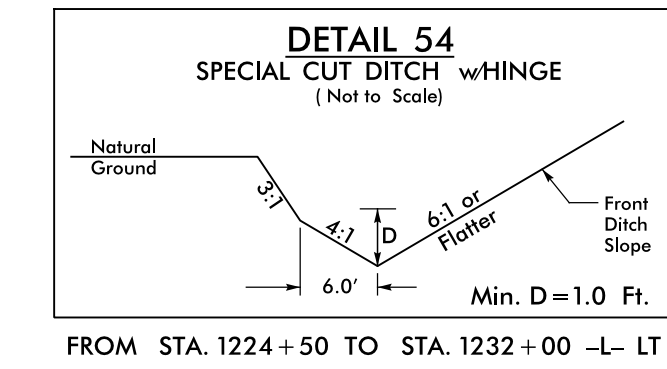
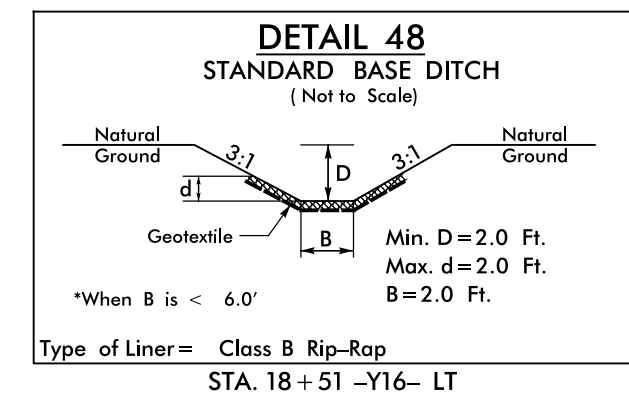
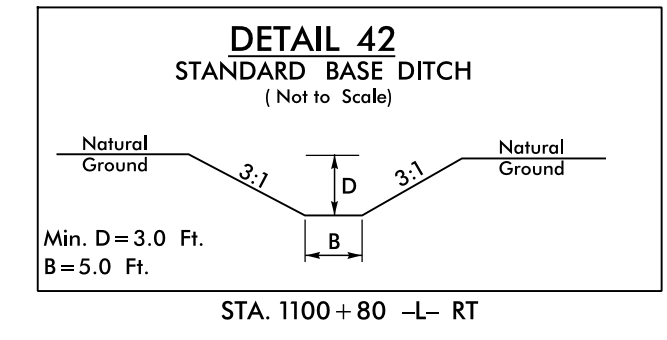
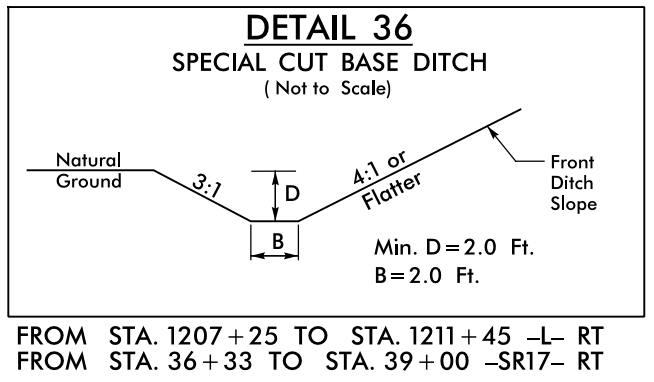
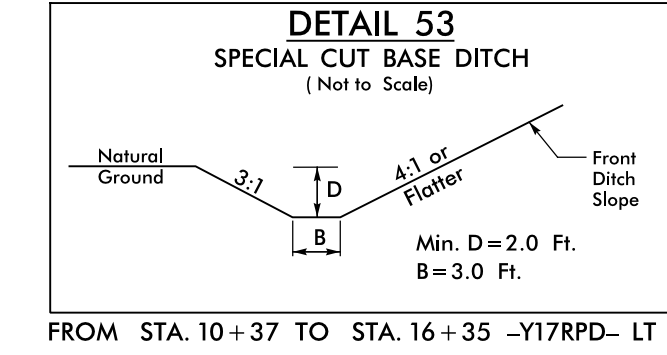
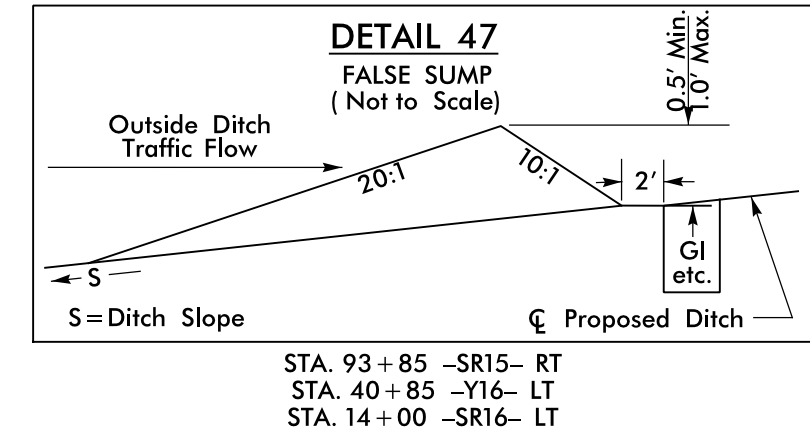
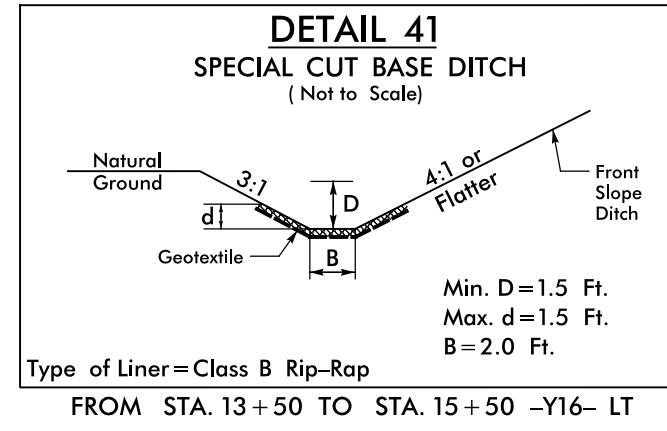
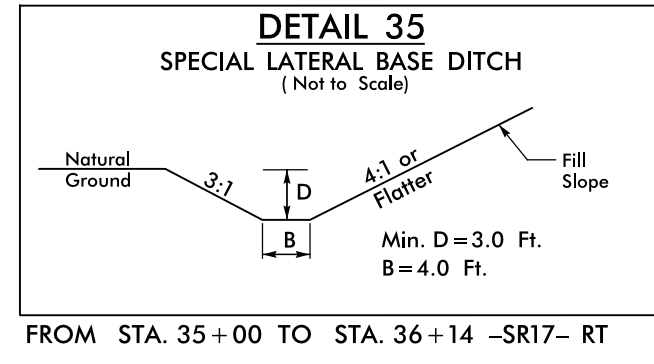

B:17/99

R:\MAR-2021\08-31\1-5986B\_Rdy-up-sh-2D-3.dgn