

**ELEVATION**

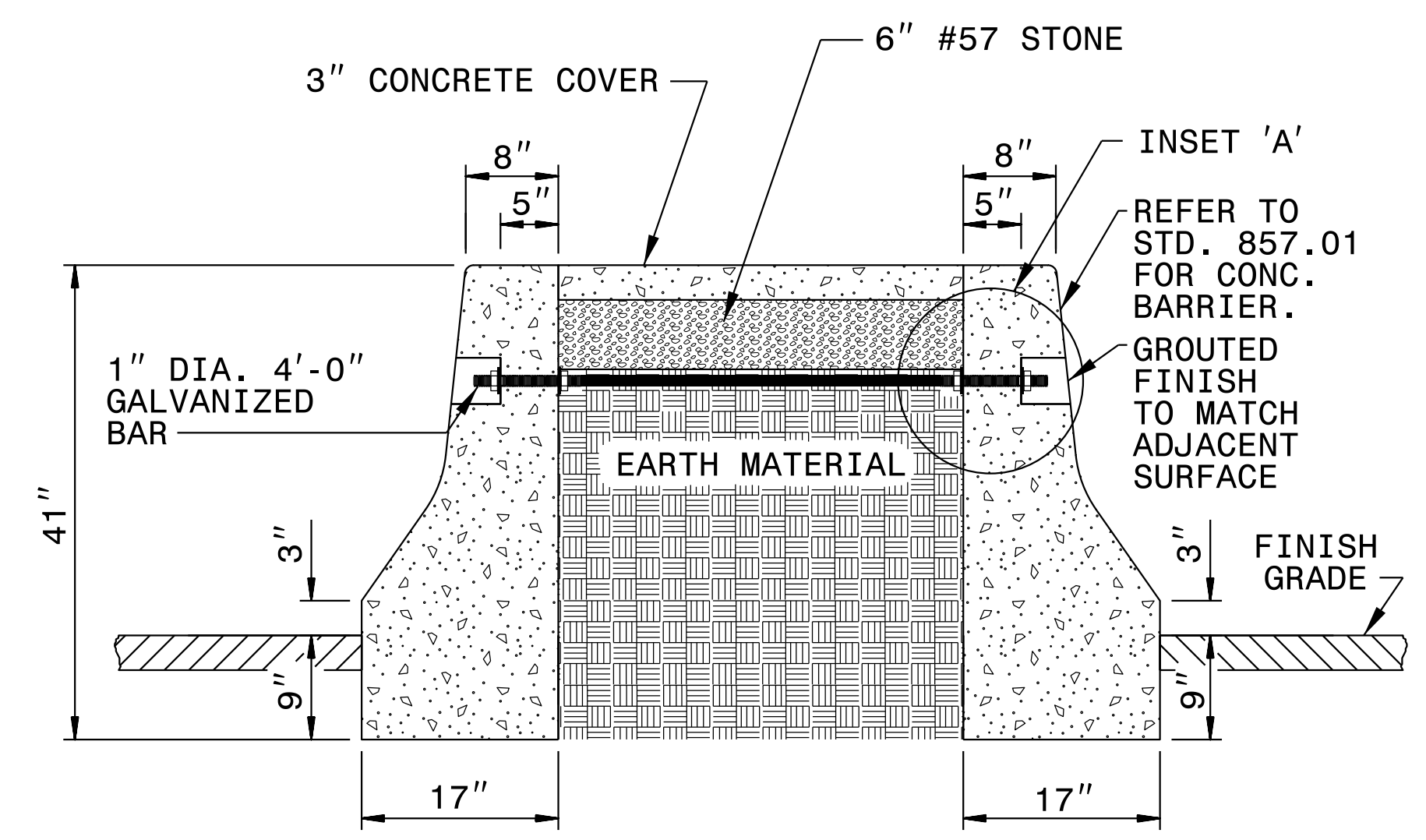

**SECTION 'A-A'**

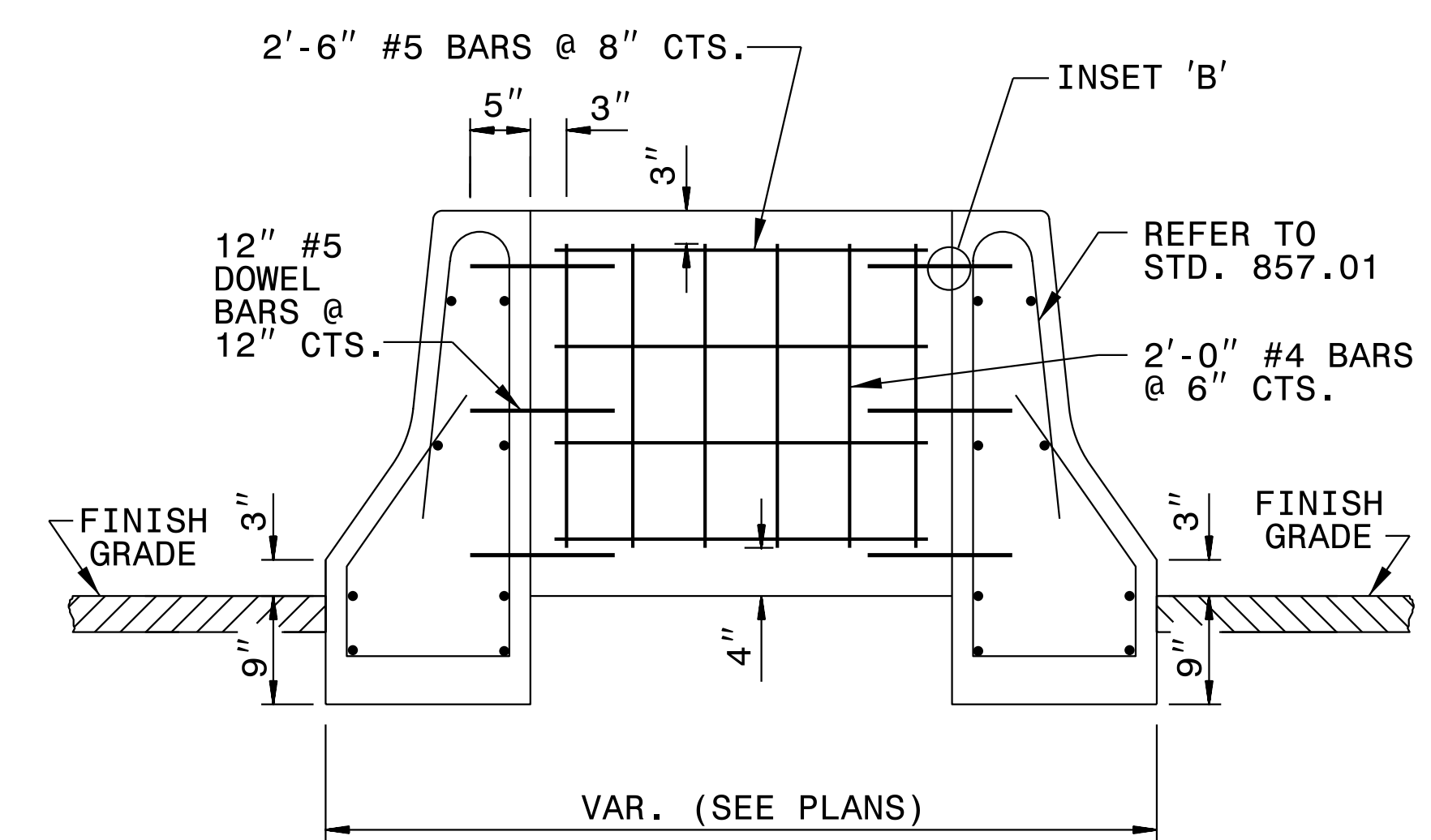

**ENDWALL**

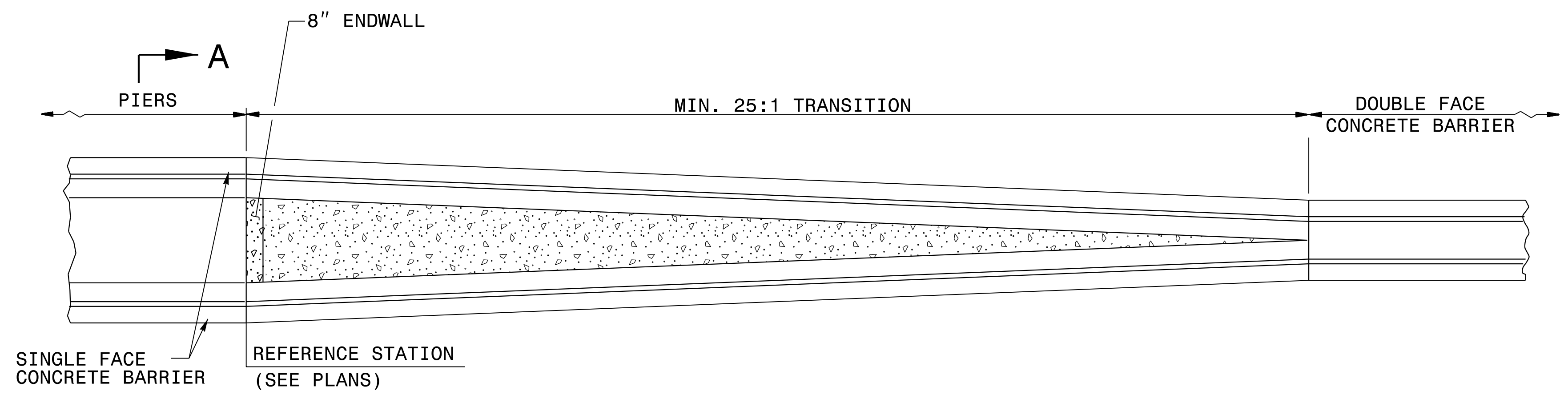

**TRANSITION FROM SINGLE FACE RAIL TO DOUBLE FACE CONCRETE MEDIAN BARRIER**

**GENERAL NOTES:**

- USE CLASS 'AA' CONCRETE TO CONSTRUCT CONCRETE BARRIER TRANSITION.
- USE CLASS 'B' CONCRETE TO CONSTRUCT CONCRETE COVER.
- SEAL ALL EXPANSION JOINTS WITH JOINT FILLER (SEE SECTION 1028 OF THE SPECIFICATIONS).
- SUBMIT ALTERNATIVE METHODS FOR STEEL FABRICATION FOR REVIEW.
- REFER TO PLANS AND TYPICAL SECTION FOR CONCRETE COVER LOCATIONS.
- USE AN APPROVED BONDING SYSTEM IN ACCORDANCE WITH SECTION 1081-1, TYPE 3A OF THE STANDARD SPECIFICATIONS.
- DRILL ANCHOR HOLES WITH A PNEUMATIC DRILL UNLESS OTHERWISE APPROVED BY THE ENGINEER.
- DRILL ANCHOR HOLES IN STRICT ACCORDANCE WITH MANUFACTURER'S RECOMMENDATIONS.
- REMOVE ALL DEBRIS, CHIPS, DUST, GREASE, OIL AND OTHER FOREIGN MATTER FROM THE ANCHOR HOLES PRIOR TO THE APPLICATION OF THE ADHEIVE BONDING SYSTEM.
- BARRIER TRANSITION LOCATED AS FIELD CONDITIONS DICTATE AND AS DIRECTED BY THE ENGINEER.

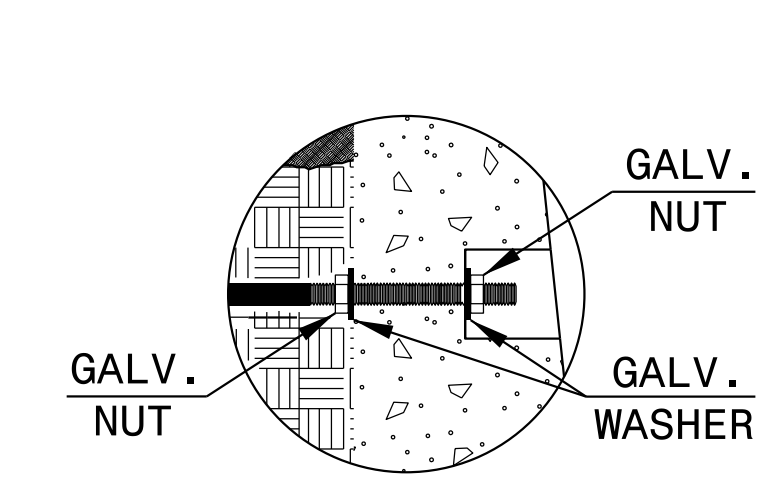

**INSET 'A'**

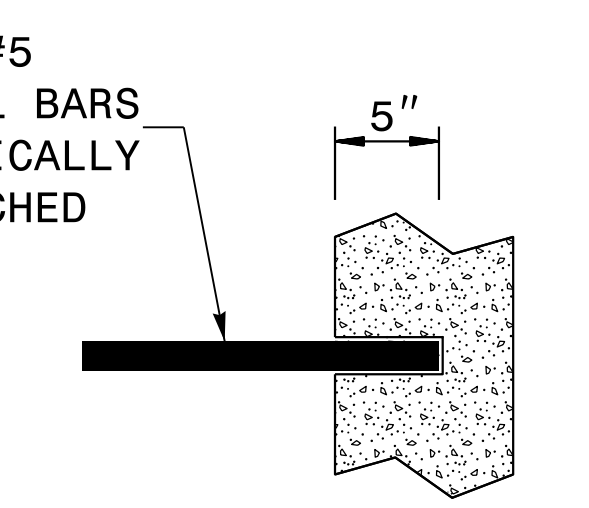

**INSET 'B'**

09-OCT-2019 09:23 S:\Contracts\Contractors\Special Details\vertical\usr\details\stand\tranbarrier.dgn J:\power\ton AT\_CSD-252595

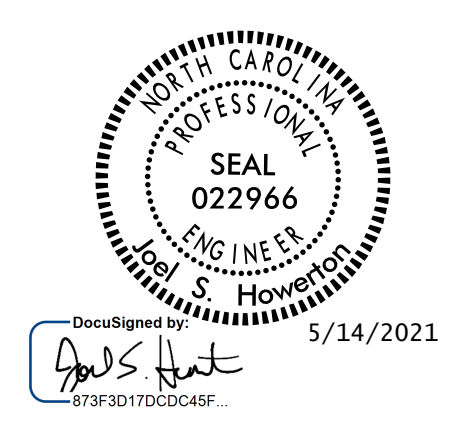

DOCUMENT NOT CONSIDERED FINAL UNLESS ALL SIGNATURES COMPLETED

<b>CONTRACT STANDARDS AND DEVELOPMENT UNIT</b>	
Office 919-707-6950 FAX 919-250-4119	
<b>MEDIAN HAZARD PROTECTION AND BARRIER TRANSITION</b>	
ORIGINAL BY: T.S. Spell	DATE: 2-14-00
MODIFIED BY:	DATE:
CHECKED BY:	DATE:
FILE SPEC.: ericward\usr\details\stand\tranbarrier.dgn	