

SECTION A-A

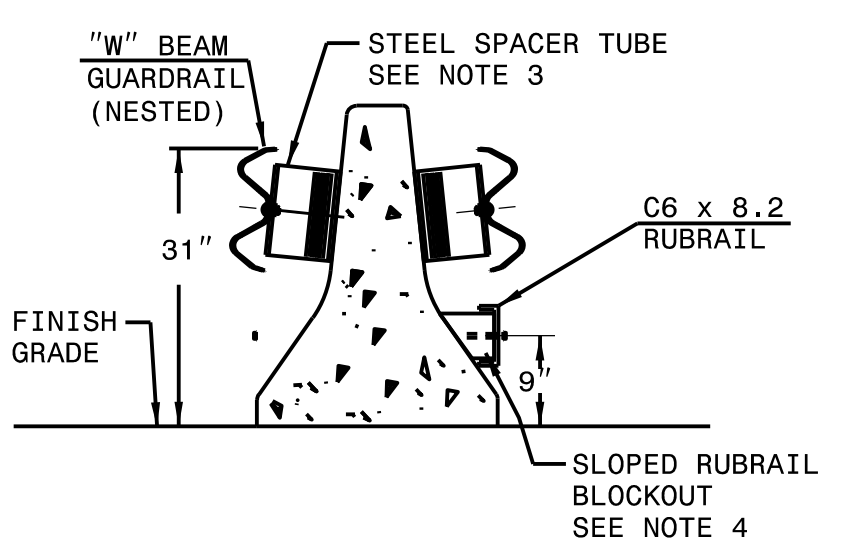

SECTION B-B

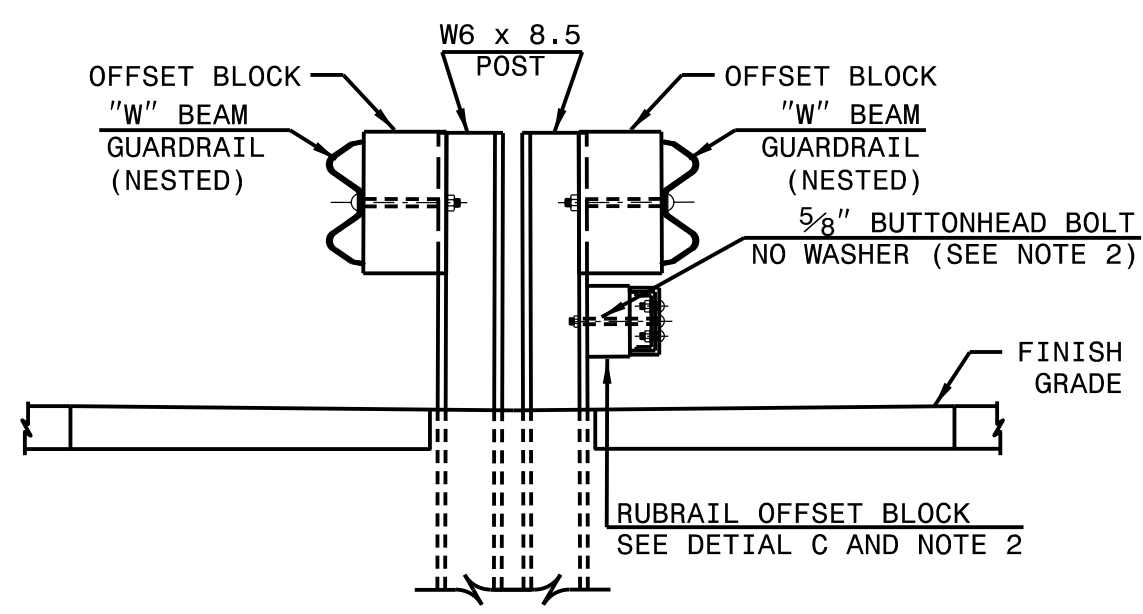

SECTION C-C

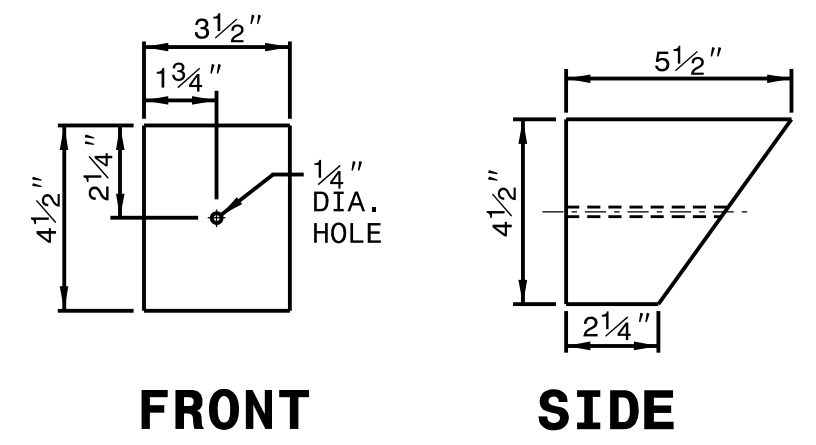

**DETAIL D
SLOPED RUBRAIL BLOCKOUT**

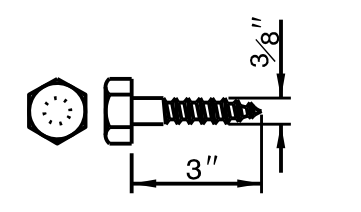

**DETAIL E
LAG BOLT**

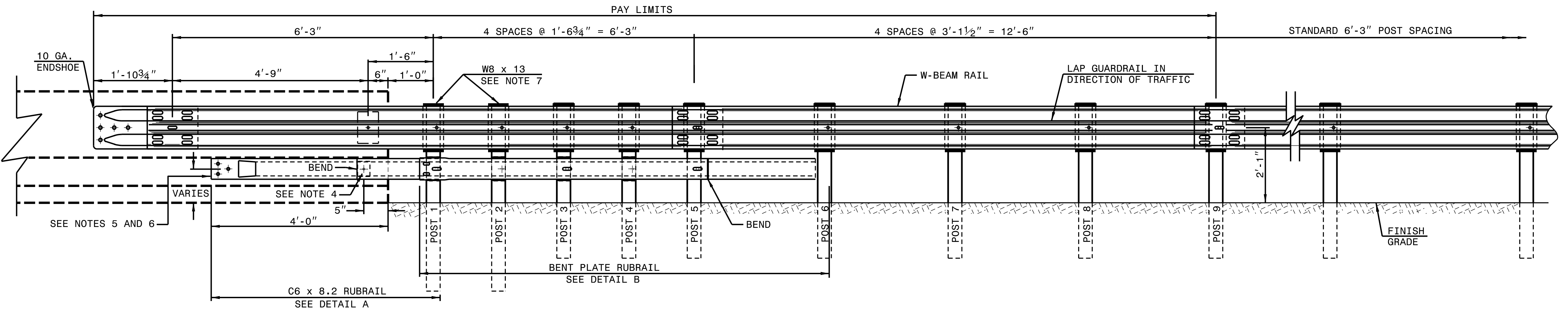

ELEVATION

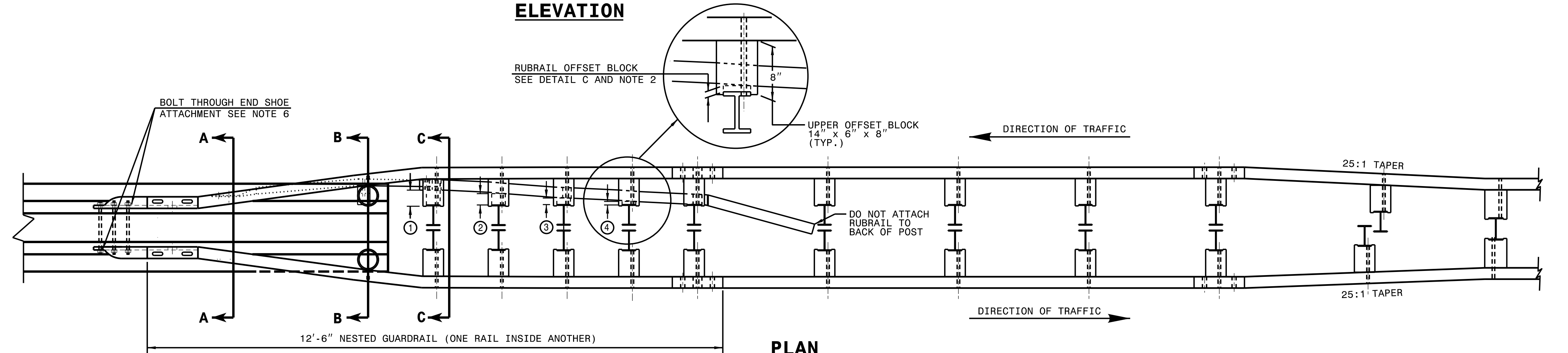

PLAN

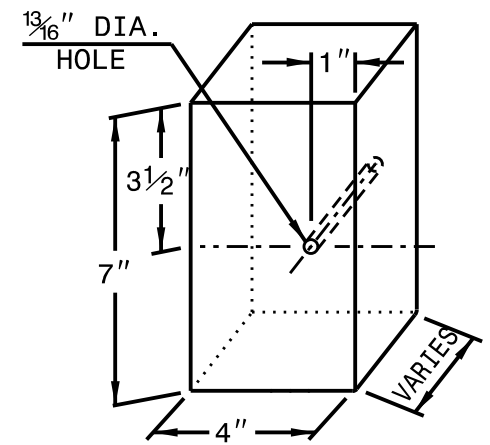

POST	THICKNESS	BOLT LENGTH
①	4 1/4"	9"
②	3 1/4"	5" *
③	2"	6"
④	1"	3" *

* BOLTS FOR POSTS 2 AND 4 ARE USED TO ATTACH BLOCK TO POST. RUBRAIL NOT ATTACHED TO BLOCK.

**DETAIL C
RUBRAIL BLOCKOUT**

- GENERAL NOTES:**
- 1) APPROACH END OF ANCHOR UNIT HAS RUBRAIL. POSTS 1 THROUGH 5 REQUIRE AN ADDITIONAL HOLE TO ATTACH LOWER BLOCKOUTS AND/OR RUBRAIL.
 - 2) RUBRAIL BLOCKOUTS LOCATED ON POSTS 1 THROUGH 4 ARE OFFSET DRILLED AND SECURED WITH 3/8" BUTTONHEAD BOLTS (SEE CHART FOR BOLT LENGTHS). SECURE RUBRAIL AND BLOCKOUTS TO POSTS 1 AND 3. RUBRAIL IS SECURED TO POST 5 WITH A 5/8" x 4 1/2" BUTTONHEAD BOLT. RUBRAIL IS FLARED TO BACK OF POST 6 AND NOT SECURED.
 - 3) STEEL SPACER TUBE IS A SCHEDULE 40 GALVANIZED PIPE 6" INSIDE DIAMETER x 9" LONG. ATTACH TUBE TO GUARDRAIL ONLY WITH 5/8" x 1 1/4" LONG BUTTONHEAD BOLT AND RECTANGULAR PLATE WASHER.
 - 4) SEE DETAIL D FOR SLOPED RUBRAIL BLOCKOUT. BLOCKOUT IS ATTACHED TO RAIL ELEMENT ONLY. USE 3/8" x 3" LAG BOLT WITH FLAT WASHER.
 - 5) SHOP FABRICATE THE C6x8.2 RUBRAIL END TO BE CONSISTENT WITH THE SLOPE OF THE JERSEY SHAPE AND ATTACH FLUSH WITH THE SLOPED TOE OF THE BARRIER.
 - 6) ANCHORAGE:
 (a) AT NEW OR EXISTING BARRIERS, RUBRAIL SHALL BE ANCHORED USING THREE 5/8" x 6" CHEMICALLY ANCHORED BOLTS WITH WASHERS. MAXIMUM PROJECTION FOR BOLTS SHALL BE 1/2".
 (b) AT NEW OR EXISTING BARRIERS, THE W-BEAM END SHOE SHALL BE ANCHORED USING FIVE 7/8" CHEMICALLY ANCHORED THREADED RODS WITH NUTS AND WASHERS. MAXIMUM PROJECTION FOR THREADED RODS SHALL BE 1/2". THE W-BEAM END SHOE SHALL BE INSTALLED BEHIND THE NESTED W-BEAM ELEMENTS.
 - 7) POSTS 1 AND 2 ARE 7'-6" LONG. ALL OTHER POSTS IN THE ANCHOR UNIT ARE 6'-0".

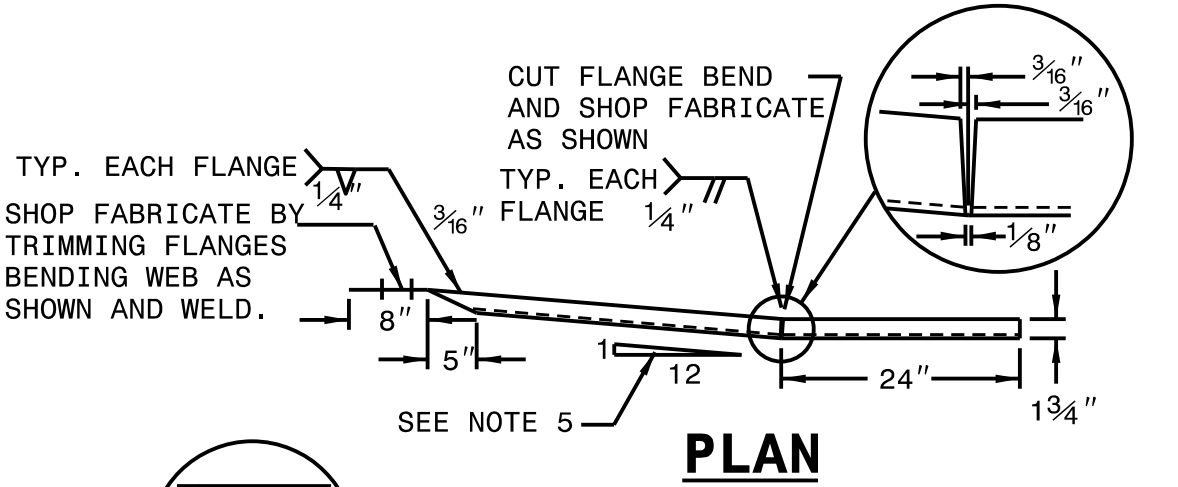

PLAN

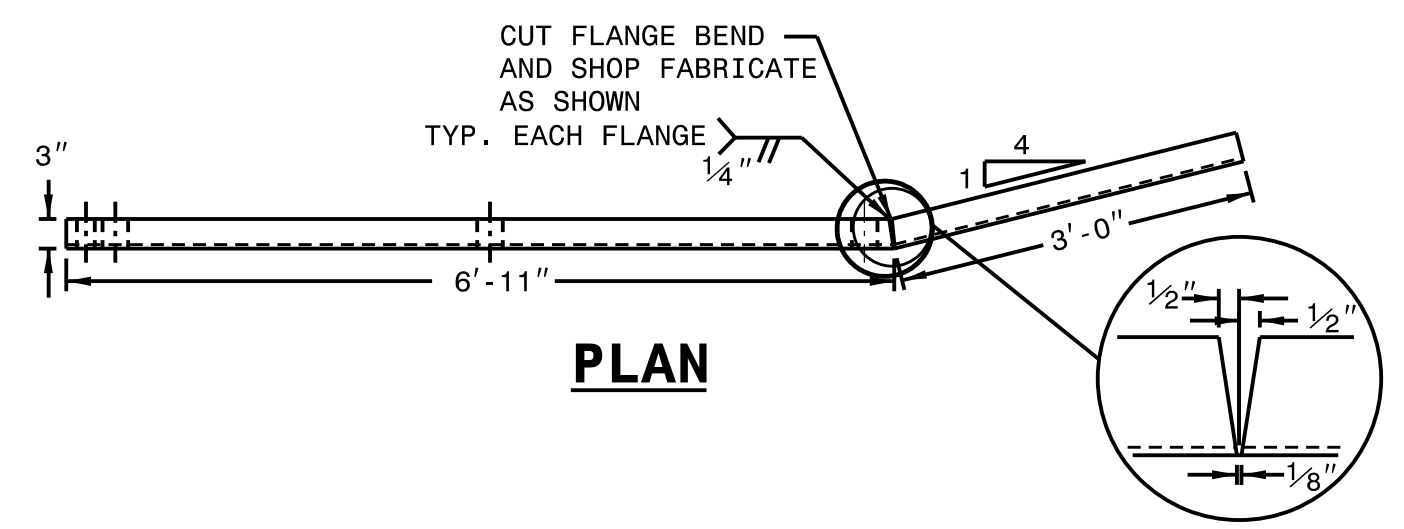

PLAN

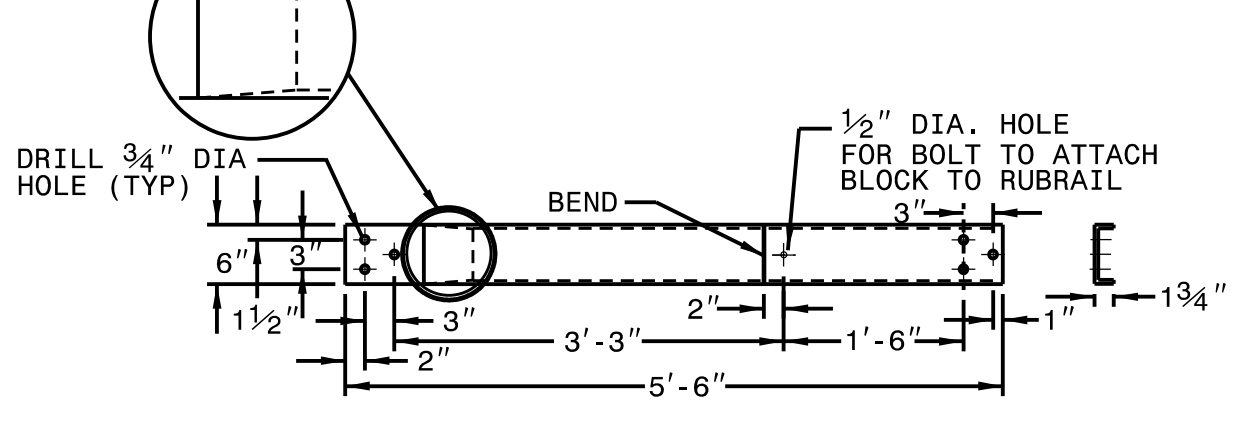

ELEVATION

**DETAIL A
C6 x 8.2 RUBRAIL**

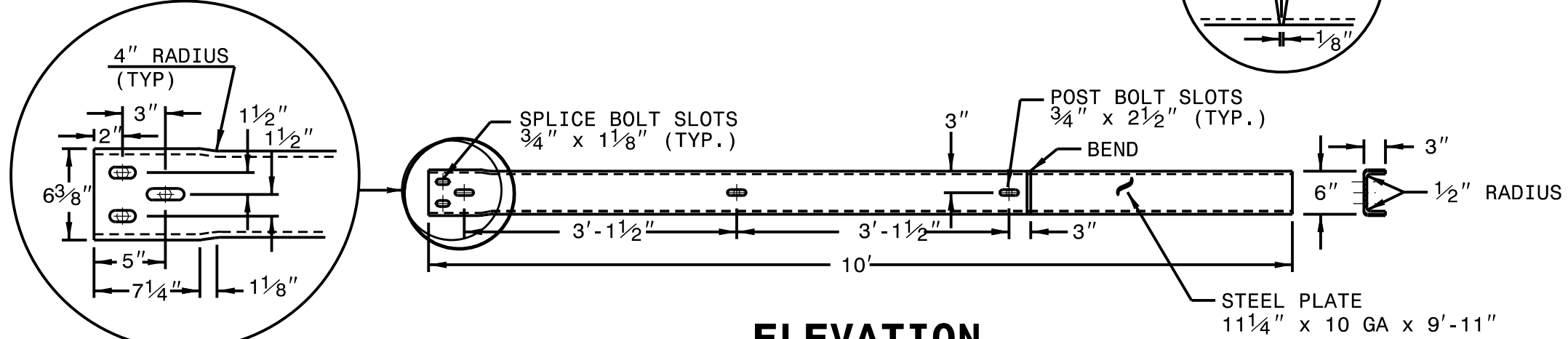

ELEVATION

**DETAIL B
BENT PLATE RUBRAIL**

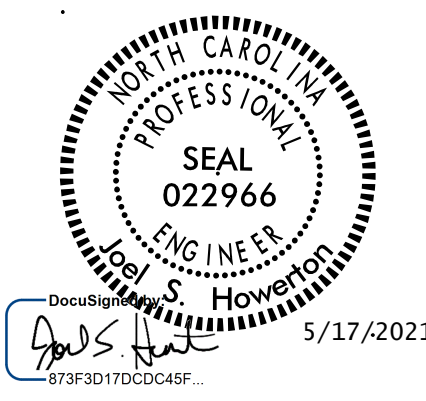

**CONTRACT STANDARDS
AND DEVELOPMENT UNIT**
Office 919-707-6950 FAX 919-250-4119

**GUARDRAIL ANCHOR UNIT
MODIFIED B-77 TYING TO
CONCRETE BARRIER**

ORIGINAL BY: E.E. WARD DATE: 5-5-03
 MODIFIED BY: DATE: _____
 CHECKED BY: DATE: _____
 FILE SPEC.: usrl\details\stand\862stds\modified B77.dgn

\$\$\$\$\$\$SYTIME\$\$\$\$\$
 \$\$\$\$\$\$CONSULTING\$\$\$\$\$
 \$\$\$\$\$\$FURNISHABLE\$\$\$\$\$
 \$\$\$\$\$\$