

PILE TYPE A18 (SPECIAL PILE)

DRAWN BY : B. L. GREEN, P.E. DATE : 3/19
 CHECKED BY : D. A. CANTRELL, P.E. DATE : 6/19
 DESIGN ENGINEER OF RECORD : B. L. GREEN, P.E. DATE : 7/19

0.6" Ø L. R. GRADE 270 STRANDS		
AREA (SQUARE INCHES)	ULTIMATE STRENGTH (LBS. PER STRAND)	APPLIED PRESTRESS (LBS. PER STRAND)
0.217	58,600	43,950

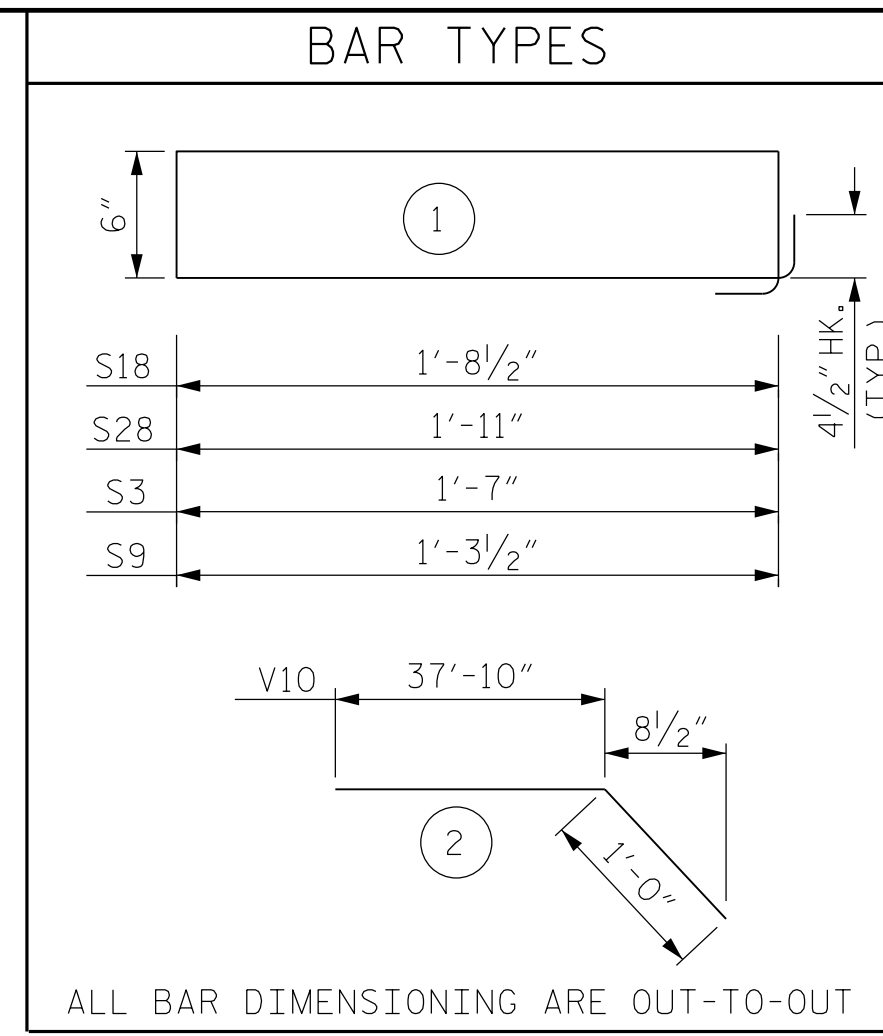

BILL OF MATERIAL A18 (SPECIAL PILE)						
BAR	NUMBER	SIZE	TYPE	LENGTH	WEIGHT	
S18	12	#4	1	5'-2"	41	
S28	42	#4	1	5'-7"	157	
S3	1	#4	1	4'-11"	3	
S9	1	#4	1	4'-4"	3	
V10	2	#5	2	38'-10"	81	

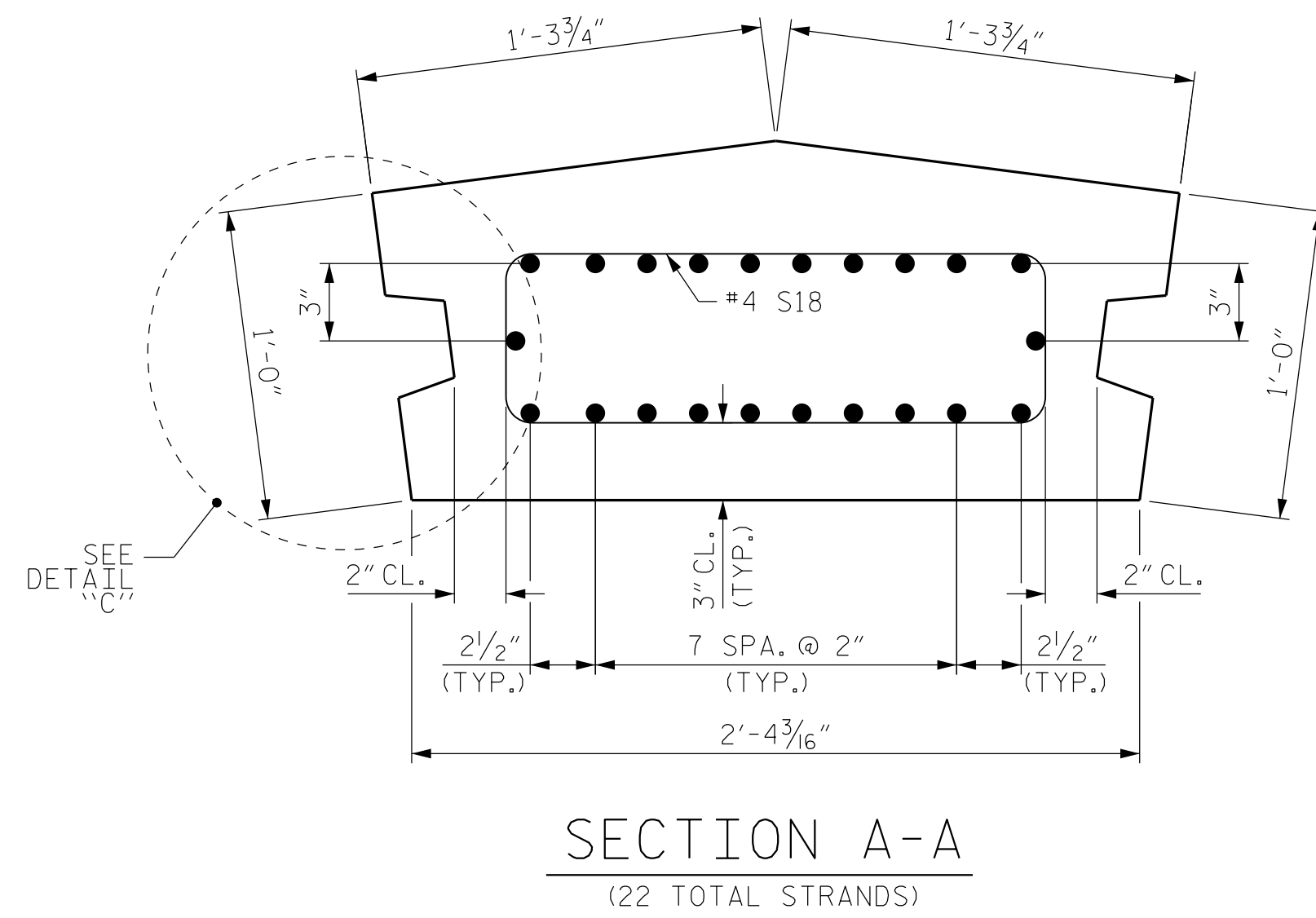

SECTION A-A (22 TOTAL STRANDS)

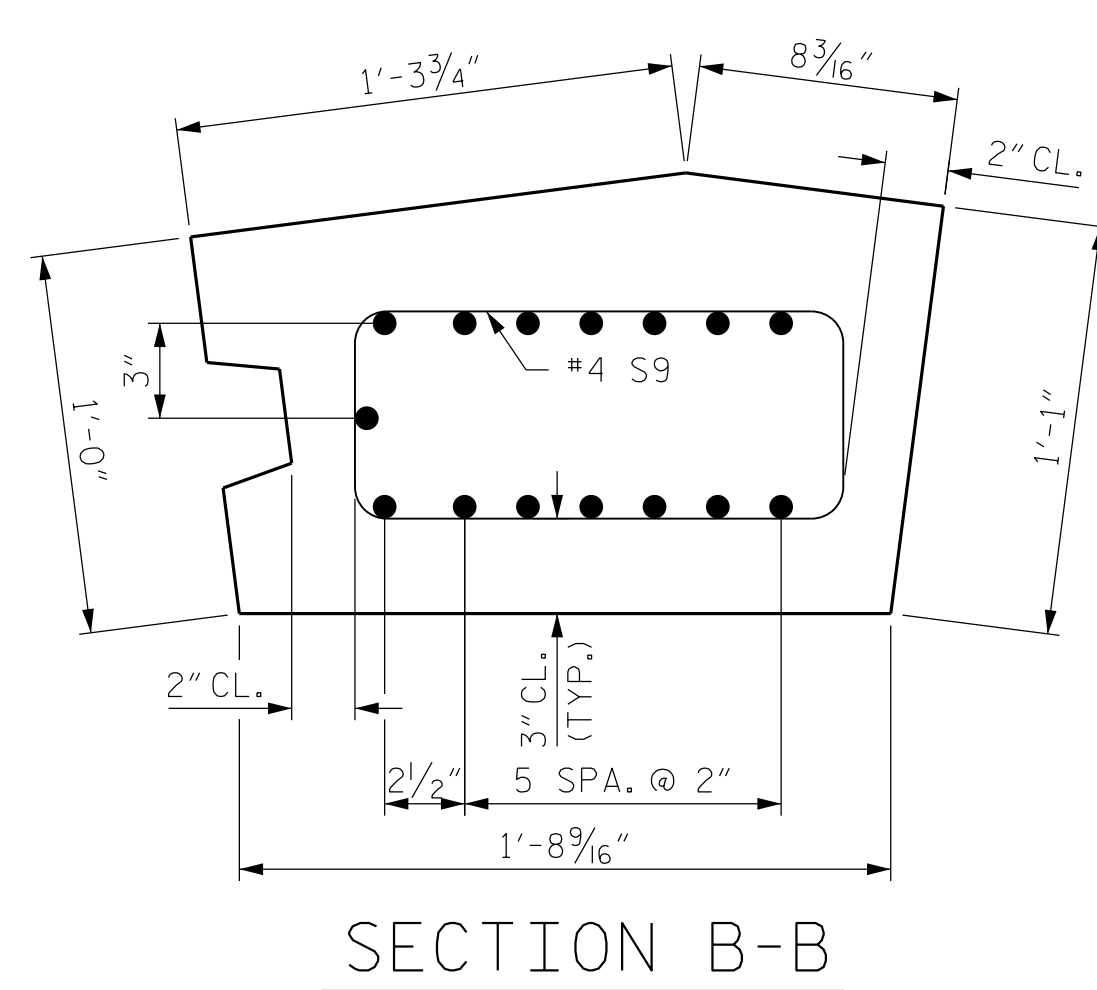

SECTION B-B

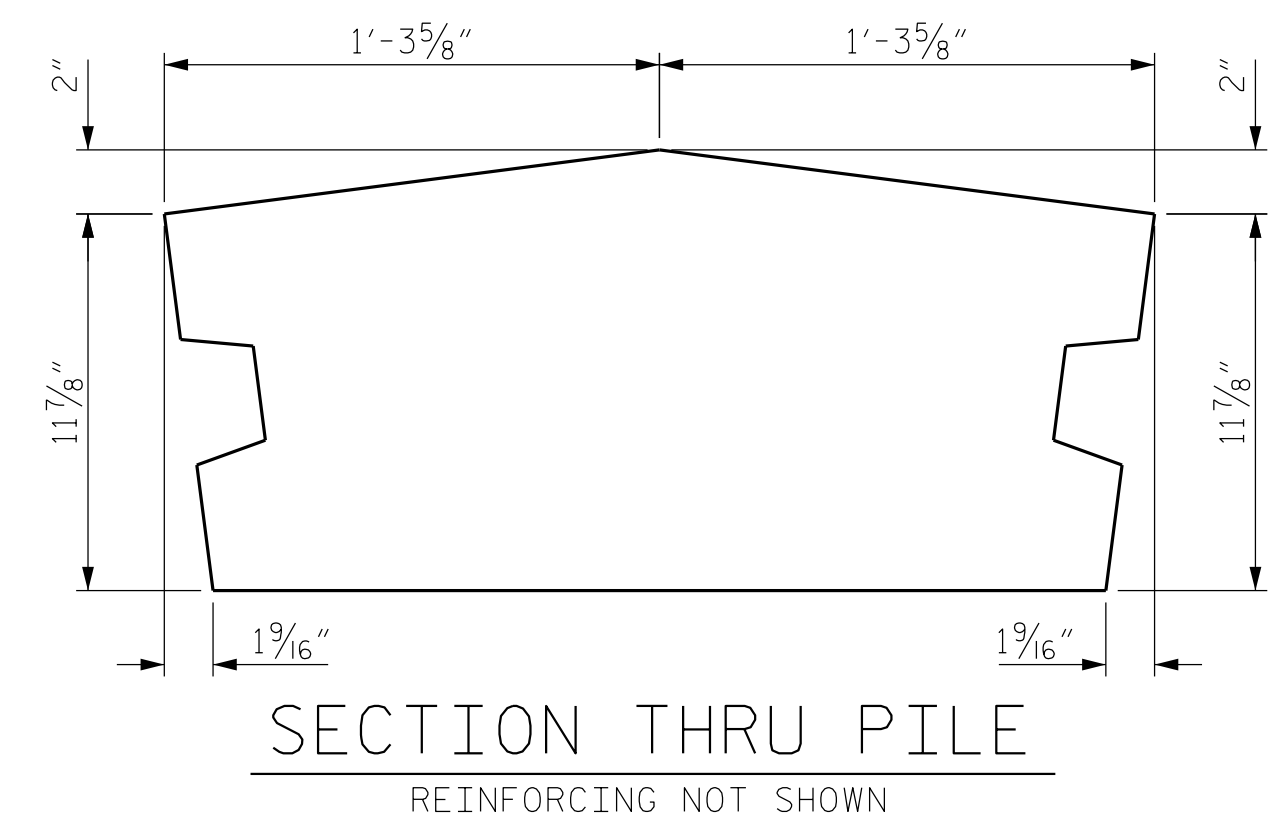

SECTION THRU PILE REINFORCING NOT SHOWN

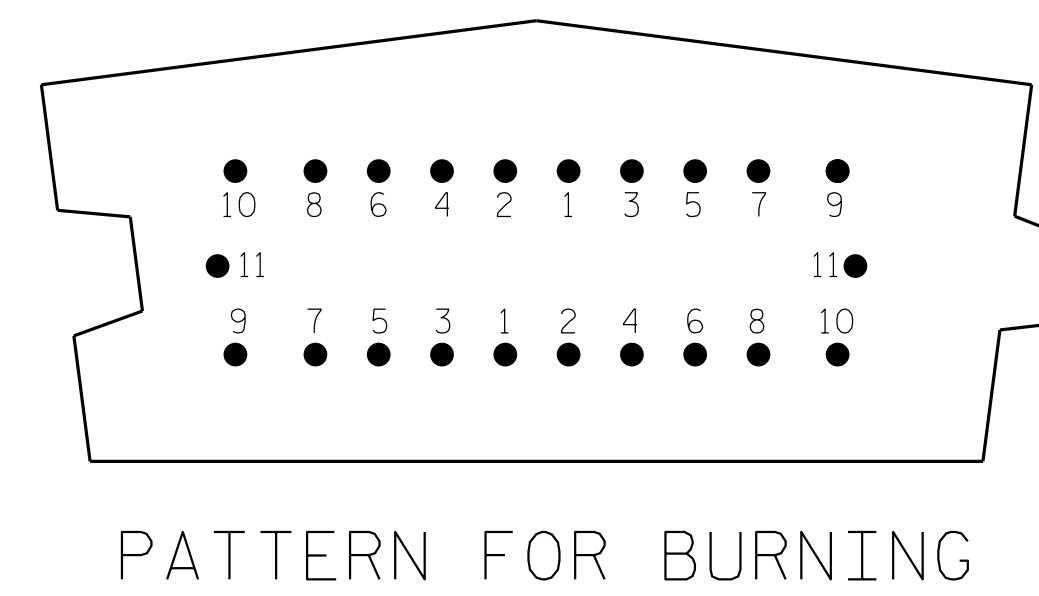

PATTERN FOR BURNING

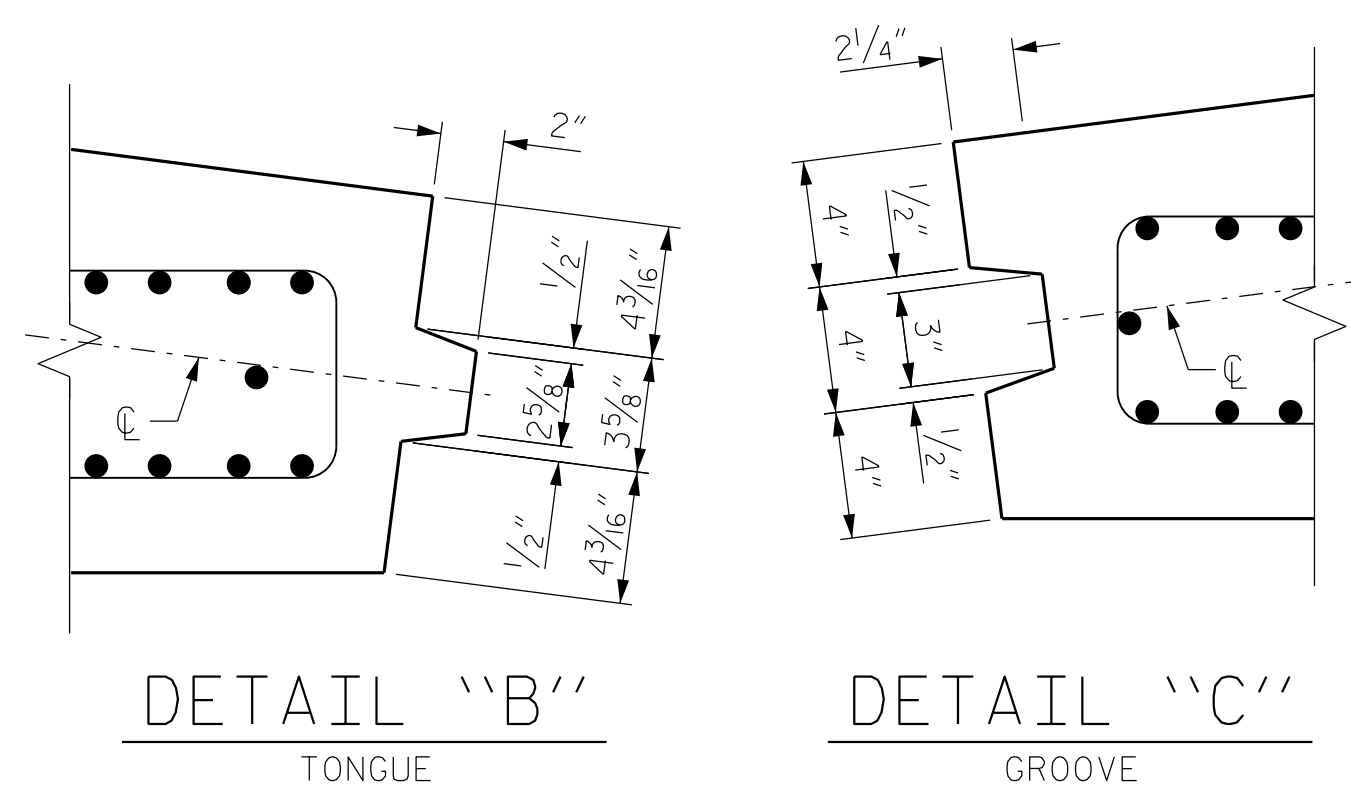

DETAIL "B" TONGUE

DETAIL "C" GROOVE

NOTES

THE SHEET PILE WIDTH DIMENSIONS ARE NOMINAL. THESE DIMENSIONS MAY BE SHORTENED BY THE MANUFACTURER UP TO 1/2" TO ALLOW FOR SHEET PILE FIT-UP IN ITS FINAL POSITION. NO CHANGES SHALL BE MADE TO THE TONGUES OR GROOVES.

THE WATER/CEMENT RATIO FOR PRESTRESSED CONCRETE SHEET PILES SHALL NOT EXCEED 0.40.

PRESTRESSED CONCRETE SHEET PILES SHALL CONTAIN CALCIUM NITRITE CORROSION INHIBITOR IN ACCORDANCE WITH THE STANDARD SPECIFICATIONS, EXCEPT THAT THE INHIBITOR SHALL BE APPLIED AT A RATE OF 4.0 GALLONS PER CUBIC YARD. NO SEPARATE PAYMENT WILL BE MADE FOR THE ADDITION OF CALCIUM NITRITE, AS IT IS CONSIDERED INCIDENTAL TO THE VARIOUS PAY ITEMS.

PRESTRESSED CONCRETE SHEET PILES SHALL CONTAIN A MINIMUM OF 25% FLY ASH CLASS F OR A MINIMUM OF 40% GROUND GRANULATED BLAST FURNACE SLAG (GGBS). ADDITIONALLY, SILICA FUME SHALL BE SUBSTITUTED FOR A MINIMUM 5% OF THE PORTLAND CEMENT BY WEIGHT IN THE PRESTRESSED CONCRETE SHEET PILES. MINERAL ADMIXTURES SHALL REPLACE THE CEMENT CONTENT AT A 1:1 RATIO BY WEIGHT. NO PAYMENT WILL BE MADE FOR THIS SUBSTITUTION, AS IT IS CONSIDERED INCIDENTAL TO THE VARIOUS PAY ITEMS.

QUANTITIES FOR ONE PILE			
PILE	REINFORCING STEEL	8,000 PSI CONCRETE	0.6" Ø L. R. STRANDS
	LB.	C.Y.	No.
A18 (SPECIAL PILE)	285	4.6	22

PROJECT NO. B-4863
 CARTERET COUNTY
 STATION: 34+75.00 -L-

SHEET 13 OF 16



DocuSigned by: Brandon Green 3/9/2020

DOCUMENT NOT CONSIDERED FINAL UNLESS ALL SIGNATURES COMPLETED

STATE OF NORTH CAROLINA DEPARTMENT OF TRANSPORTATION RALEIGH					
CONCRETE SHEET PILE RETAINING WALL SHEET PILE DETAILS					
REVISIONS					SHEET NO.
NO.	BY:	DATE:	NO.	BY:	DATE:
1			3		
2			4		
					W-13
					TOTAL SHEETS 24