

PILE TYPE A1  
(STARTER PILE)

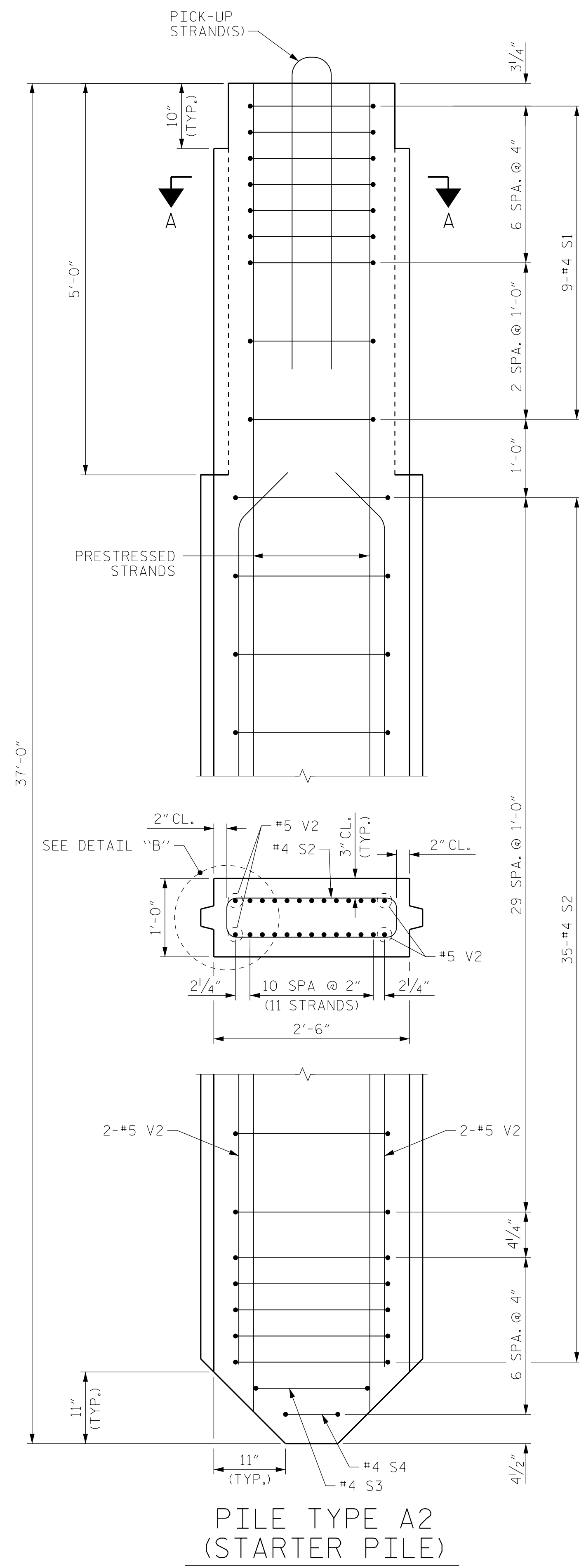

PILE TYPE A2  
(STARTER PILE)

0.6" Ø L. R. GRADE 270 STRANDS		
AREA (SQUARE INCHES)	ULTIMATE STRENGTH (LBS. PER STRAND)	APPLIED PRESTRESS (LBS. PER STRAND)
0.217	58,600	43,950

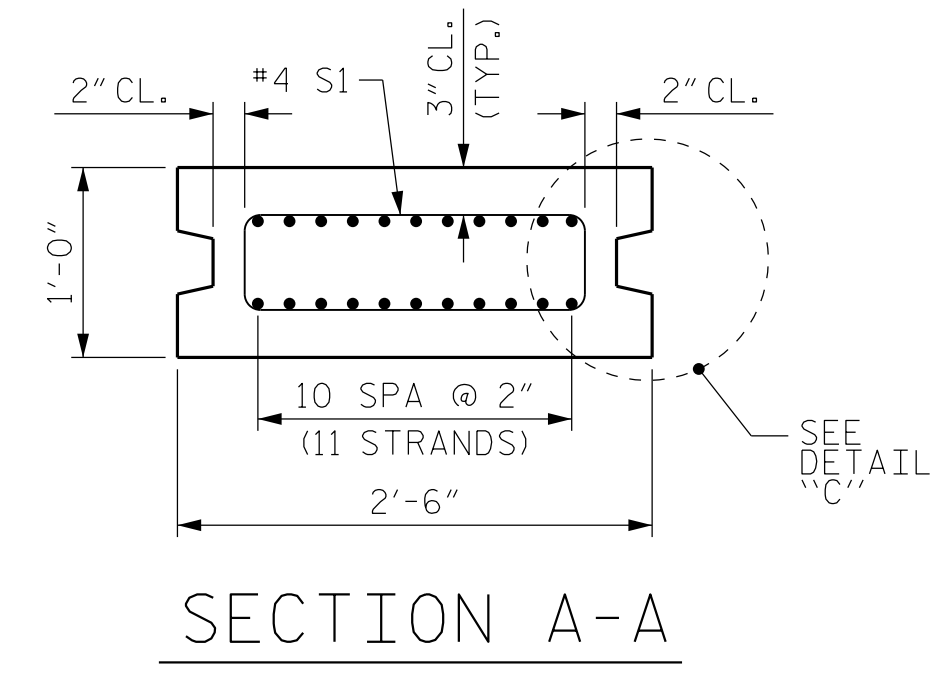

SECTION A-A

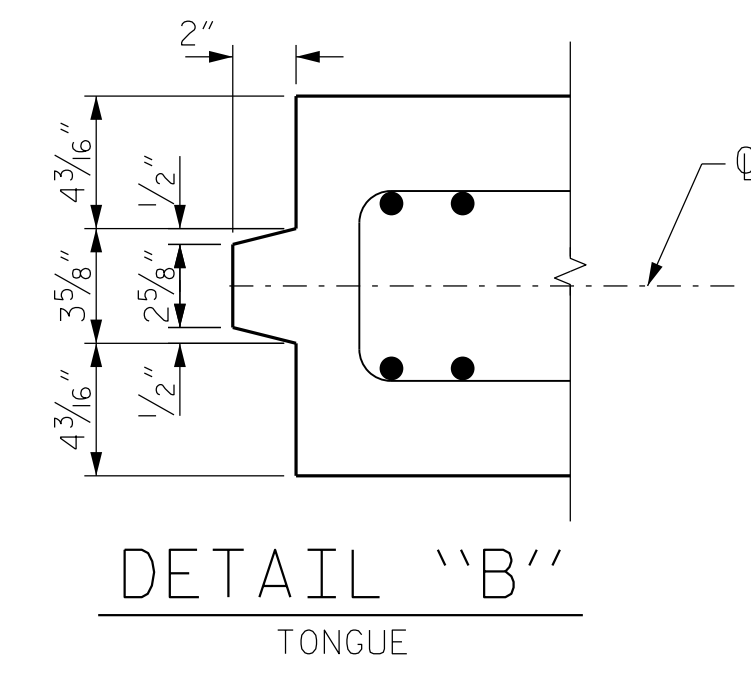

DETAIL "B"  
TONGUE

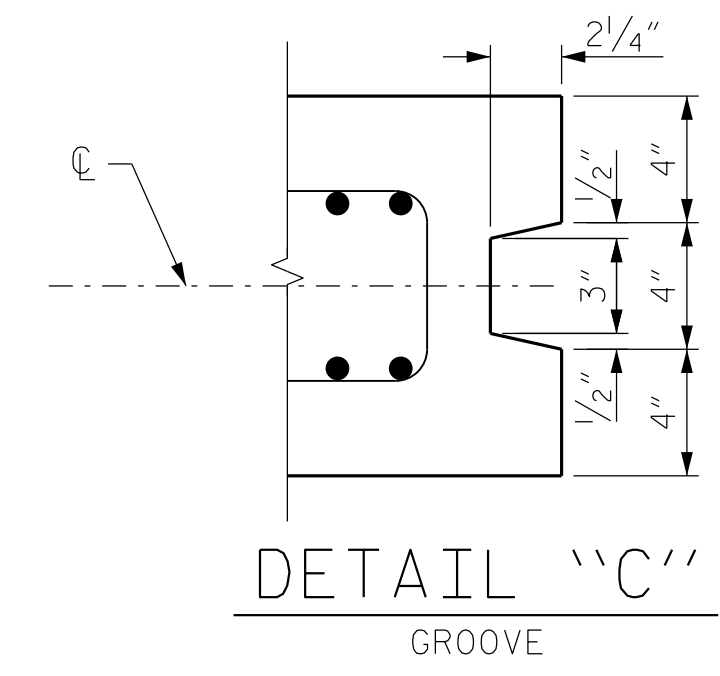

DETAIL "C"  
GROOVE

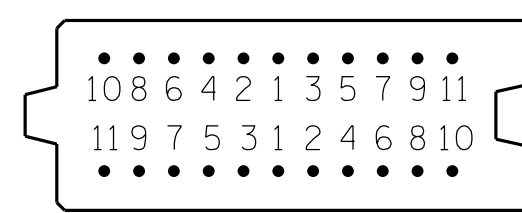

PATTERN FOR BURNING

NOTES

THE SHEET PILE WIDTH DIMENSIONS ARE NOMINAL. THESE DIMENSIONS MAY BE SHORTENED BY THE MANUFACTURER UP TO 1/2" TO ALLOW FOR SHEET PILE FIT-UP IN ITS FINAL POSITION. NO CHANGES SHALL BE MADE TO THE TONGUES OR GROOVES.

THE WATER/CEMENT RATIO FOR PRESTRESSED CONCRETE SHEET PILES SHALL NOT EXCEED 0.40.

PRESTRESSED CONCRETE SHEET PILES SHALL CONTAIN CALCIUM NITRITE CORROSION INHIBITOR IN ACCORDANCE WITH THE STANDARD SPECIFICATIONS, EXCEPT THAT THE INHIBITOR SHALL BE APPLIED AT A RATE OF 4.0 GALLONS PER CUBIC YARD. NO SEPARATE PAYMENT WILL BE MADE FOR THE ADDITION OF CALCIUM NITRITE, AS IT IS CONSIDERED INCIDENTAL TO THE VARIOUS PAY ITEMS.

PRESTRESSED CONCRETE SHEET PILES SHALL CONTAIN A MINIMUM OF 25% FLY ASH CLASS F OR A MINIMUM OF 40% GROUND GRANULATED BLAST FURNACE SLAG (GGBFS). ADDITIONALLY, SILICA FUME SHALL BE SUBSTITUTED FOR A MINIMUM 5% OF THE PORTLAND CEMENT BY WEIGHT IN THE PRESTRESSED CONCRETE SHEET PILES. MINERAL ADMIXTURES SHALL REPLACE THE CEMENT CONTENT AT A 1:1 RATIO BY WEIGHT. NO PAYMENT WILL BE MADE FOR THIS SUBSTITUTION, AS IT IS CONSIDERED INCIDENTAL TO THE VARIOUS PAY ITEMS.

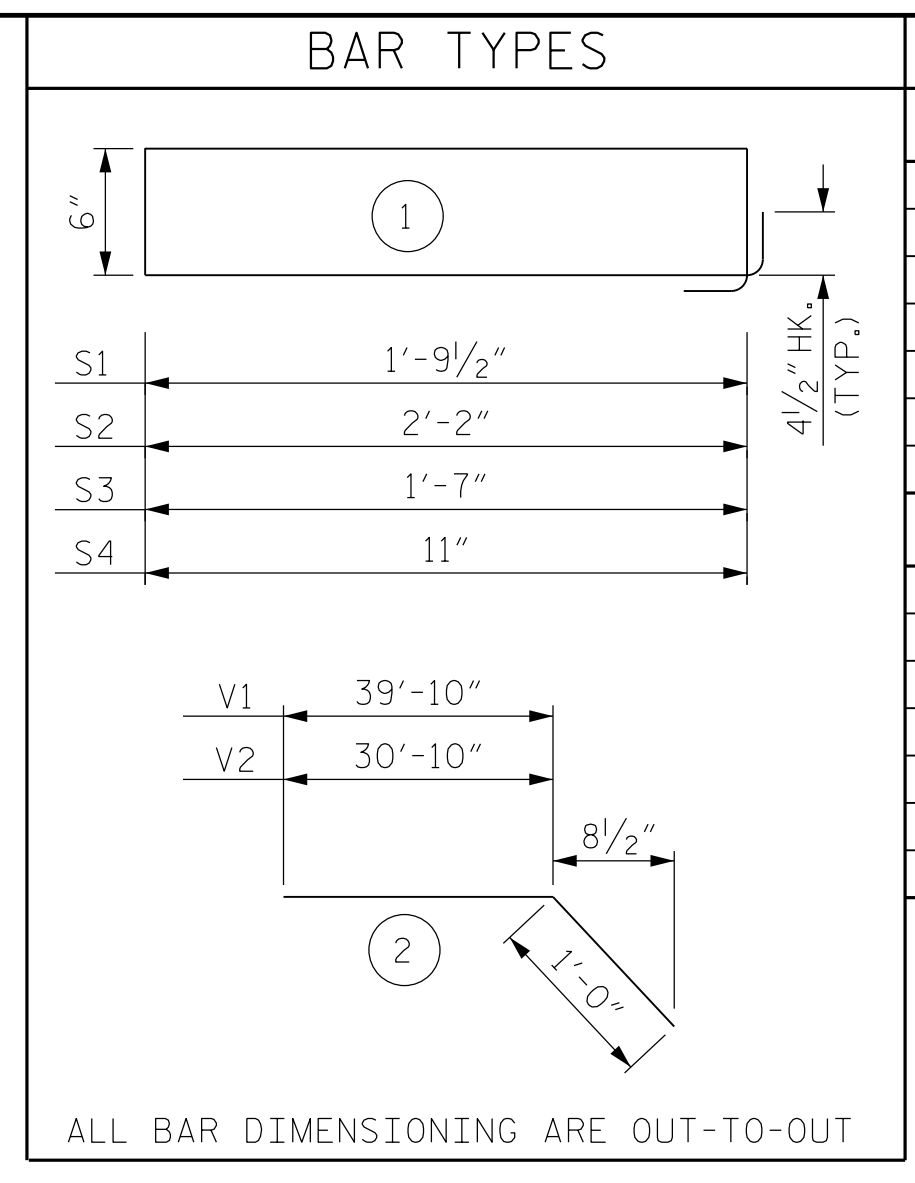

BAR TYPES

BILL OF MATERIAL					
A1 (STARTER PILE)					
BAR	NUMBER	SIZE	TYPE	LENGTH	WEIGHT
S1	14	#4	1	5'-4"	50
S2	44	#4	1	6'-1"	179
S3	1	#4	1	4'-11"	4
S4	1	#4	1	3'-7"	3
V1	4	#5	2	40'-10"	171

A2 (STARTER PILE)					
BAR	NUMBER	SIZE	TYPE	LENGTH	WEIGHT
S1	9	#4	1	5'-4"	33
S2	35	#4	1	6'-1"	143
S3	1	#4	1	4'-11"	4
S4	1	#4	1	3'-7"	3
V2	4	#5	2	31'-10"	133

QUANTITIES FOR ONE PILE			
PILE	REINFORCING STEEL	8,000 PSI CONCRETE	0.6" Ø L. R. STRANDS
	LB.	C.Y.	No.
A1 (STARTER PILE)	407	4.7	22
A2 (STARTER PILE)	316	3.4	22

PROJECT NO. B-4863  
CARTERET COUNTY  
 STATION: 34+75.00 -L-

SHEET 6 OF 16

STATE OF NORTH CAROLINA  
 DEPARTMENT OF TRANSPORTATION  
 RALEIGH

CONCRETE SHEET PILE  
 RETAINING WALL  
 SHEET PILE DETAILS



DocuSigned by:  
 Brandon L. Green  
 202702886861448  
 3/9/2020

DOCUMENT NOT CONSIDERED  
 FINAL UNLESS ALL  
 SIGNATURES COMPLETED

REVISIONS						SHEET NO.
NO.	BY:	DATE:	NO.	BY:	DATE:	W-06
1			3			TOTAL SHEETS
2			4			24

DRAWN BY : B. L. GREEN, P.E. DATE : 3/19  
 CHECKED BY : D. A. CANTRELL, P.E. DATE : 6/19  
 DESIGN ENGINEER OF RECORD: B. L. GREEN, P.E. DATE : 7/19