

NOTES

STIRRUPS AND U1 BARS IN CAP MAY BE SHIFTED AS NECESSARY TO CLEAR ANCHOR BOLTS.
 HOOKS ON "V" AND "M" BARS MAY BE TURNED AS NECESSARY FOR PLACING REINFORCING BARS.
 CONCRETE DISPLACED BY CONCRETE PILES HAS BEEN DEDUCTED FROM THE FOOTING CONCRETE QUANTITY.
 ALL REINFORCING IN THE CAP, COLUMNS AND FOOTING IS TO BE GLASS FIBER REINFORCED POLYMER (GFRP) BARS. FOR GLASS FIBER REINFORCED POLYMER BARS, SEE SPECIAL PROVISIONS.
 * THE FOOTING HAS A DROP OF 2" FROM THE CENTER OF THE FOOTING TO THE EDGE OF THE FOOTING TO ACCOMMODATE DRAINAGE.

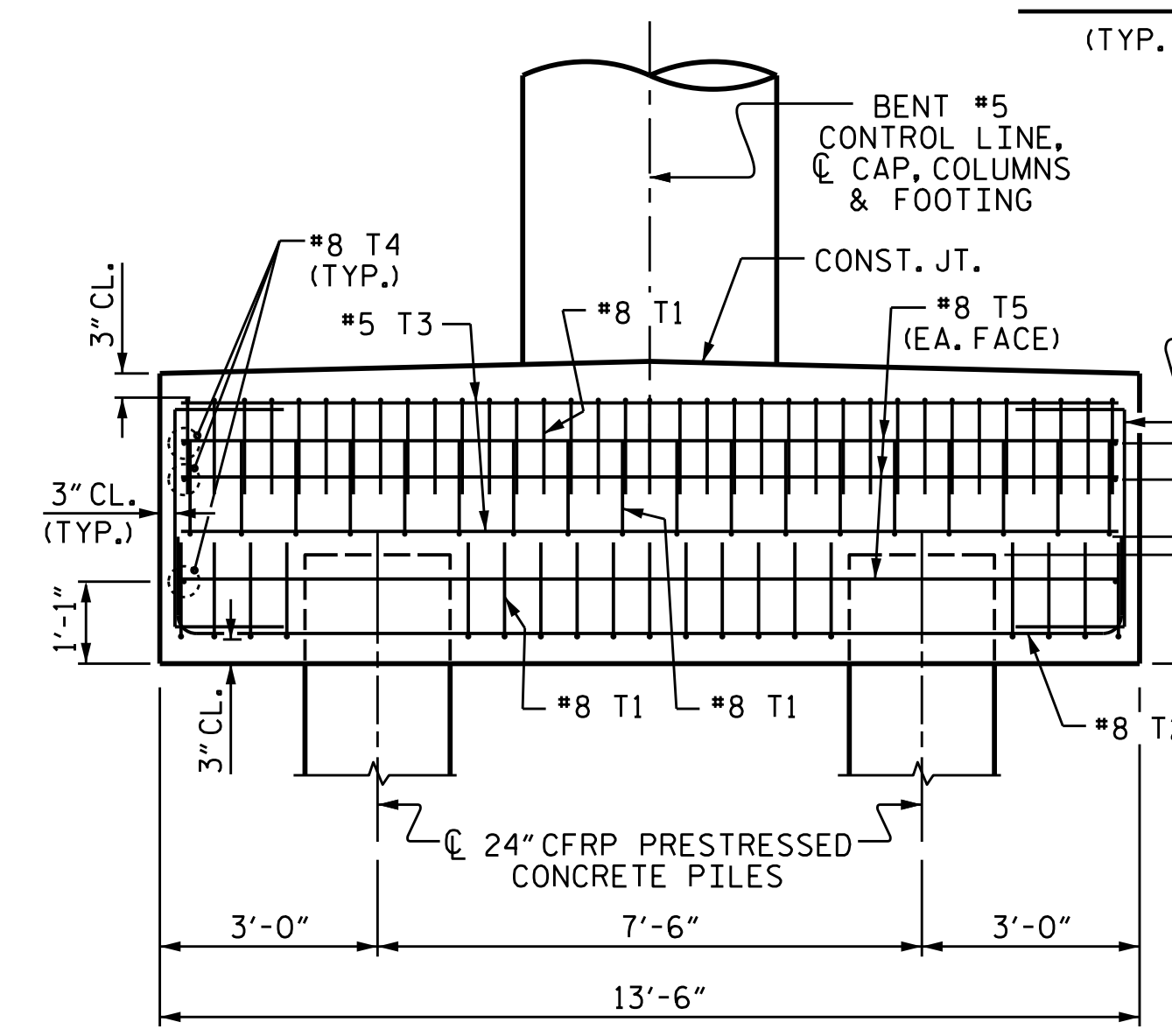
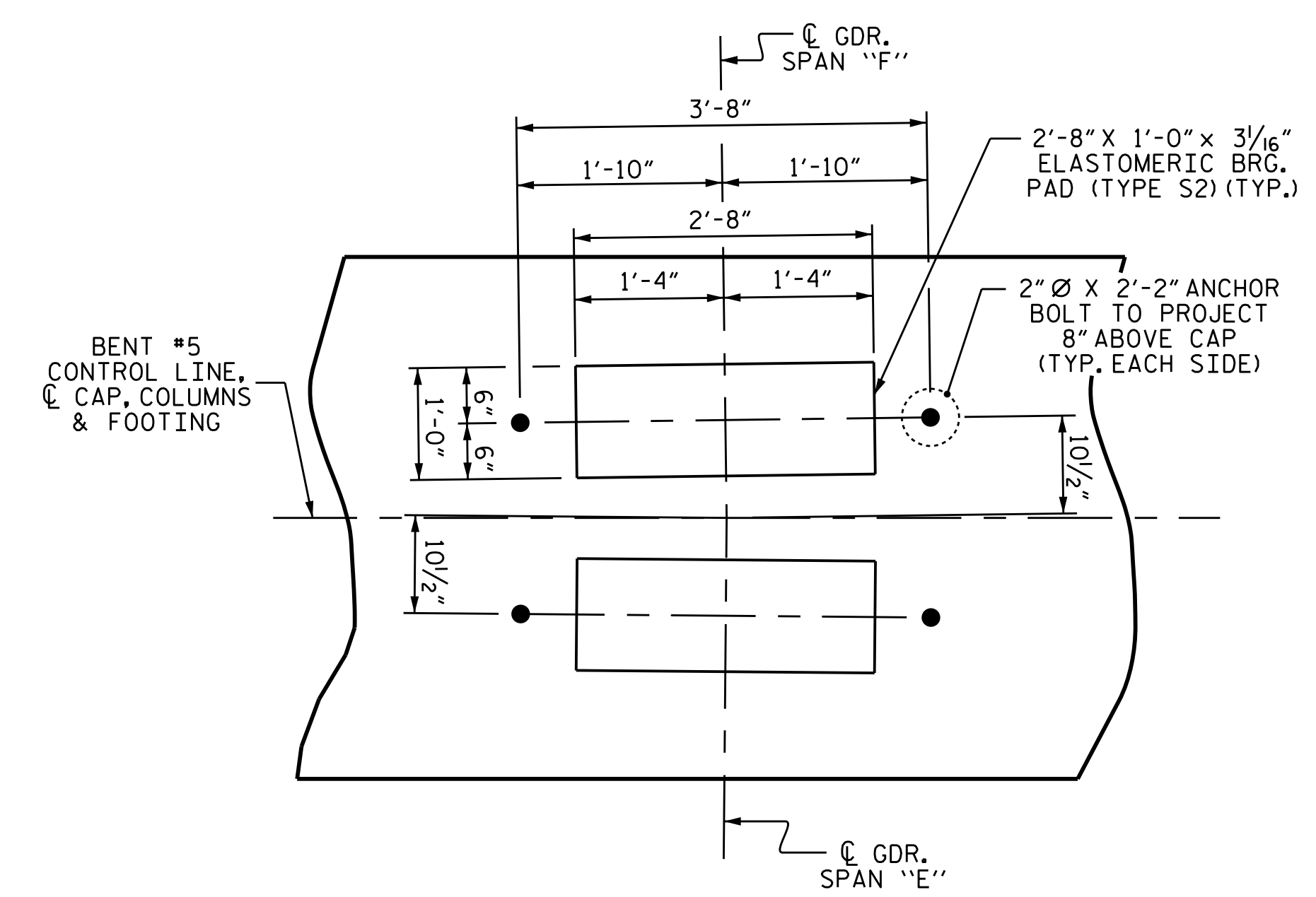
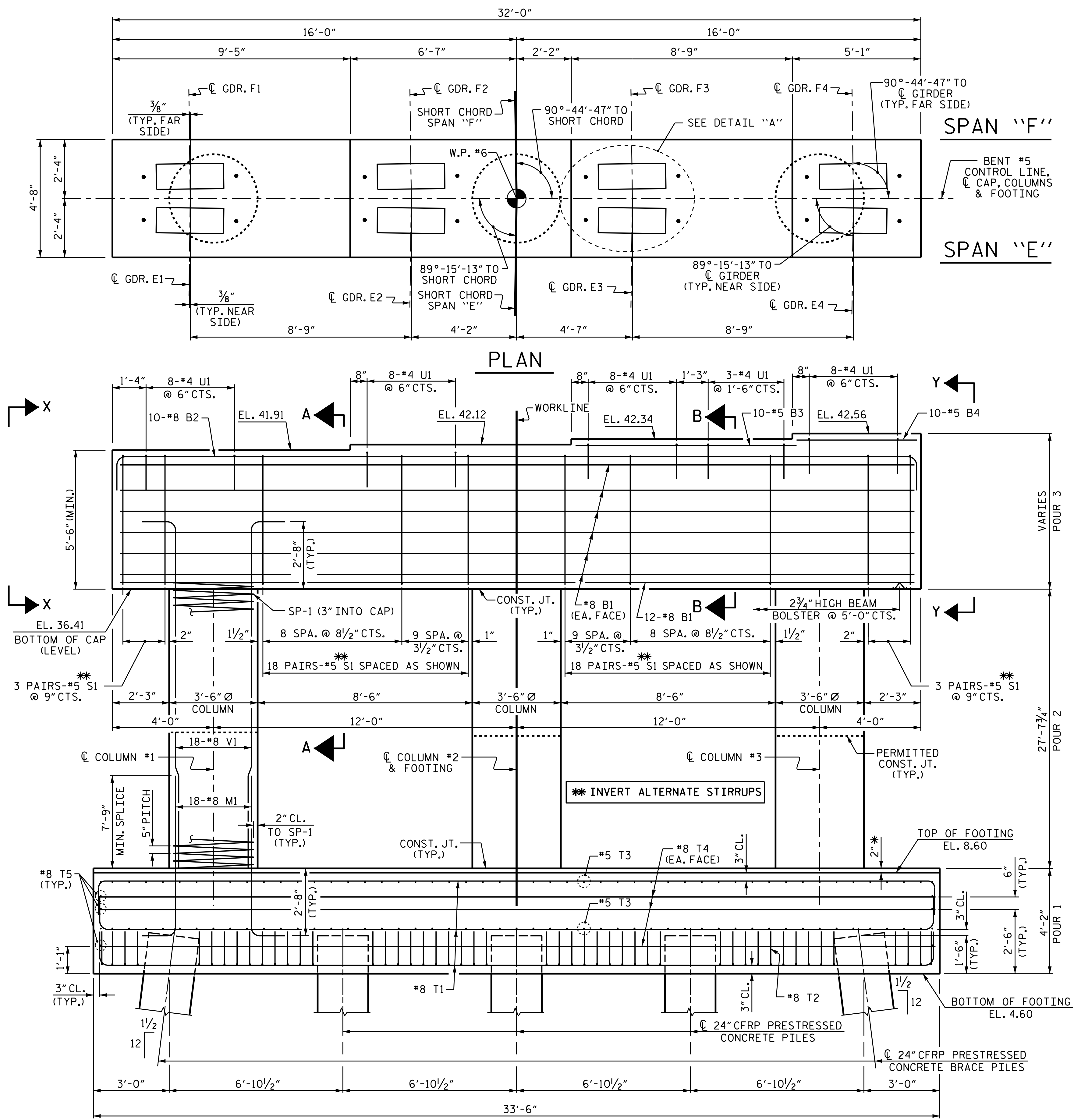

PROJECT NO. B-4863
 CARTERET COUNTY
 STATION: 34+75.00 -L-

PARTIAL END ELEVATION
 SEE ELEVATION FOR COLUMN REINFORCING BARS

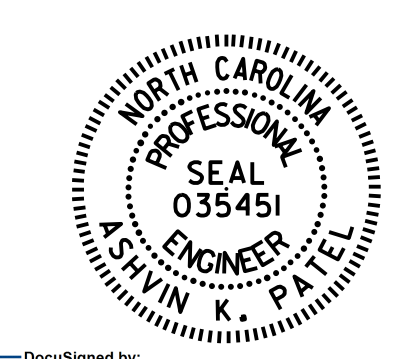

STATE OF NORTH CAROLINA
 DEPARTMENT OF TRANSPORTATION
 RALEIGH
 SUBSTRUCTURE
 BENT #5

DRAWN BY : I.L. AVERETTE DATE : 02/2019
 CHECKED BY : A.K. PATEL DATE : 04/2019
 DESIGN ENGINEER OF RECORD : A.K. PATEL DATE : 04/2019

REINFORCING BAR DIMENSIONS AND DETAILS ARE TYPICAL FOR EACH COLUMN
 FOR ADDITIONAL REINFORCING BARS IN ENDS OF CAP, SEE VIEW X-X AND VIEW Y-Y ON SHEET 3 OF 3
 *4 U5 BARS IN FOOTING NOT SHOWN, SEE SHEET 2 OF 3

DOCUMENT NOT CONSIDERED
 FINAL UNLESS ALL
 SIGNATURES COMPLETED

REVISIONS						SHEET NO.
NO.	BY:	DATE:	NO.	BY:	DATE:	TOTAL SHEETS
1			3			S1-133
2			4			194