

SPAN X, Y AND Z  
PLAN OF PARAPET

FOR DETAILS OF PARAPET, ENDPOSTS, AND ADDITIONAL REINFORCEMENT, SEE SHEET 14 OF 14. ALL DIMENSIONS ARE TAKEN ALONG THE ARC OF THE OUTSIDE EDGE OF SUPERSTRUCTURE

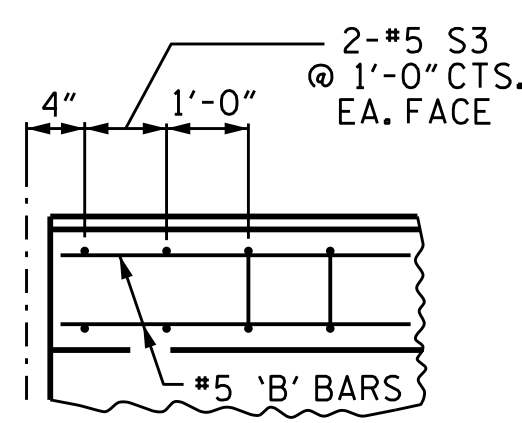

DETAIL 'A'

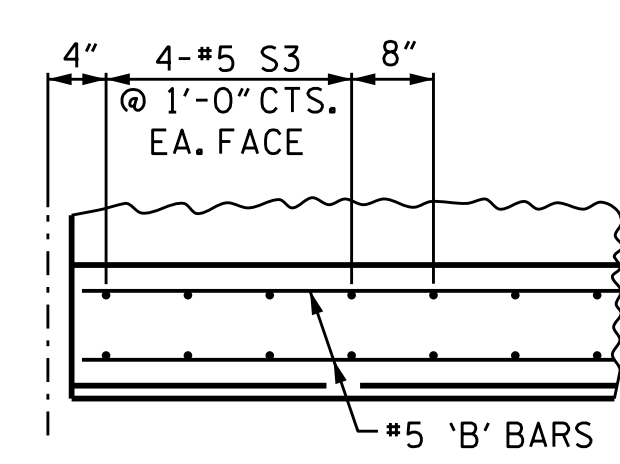

DETAIL 'B'

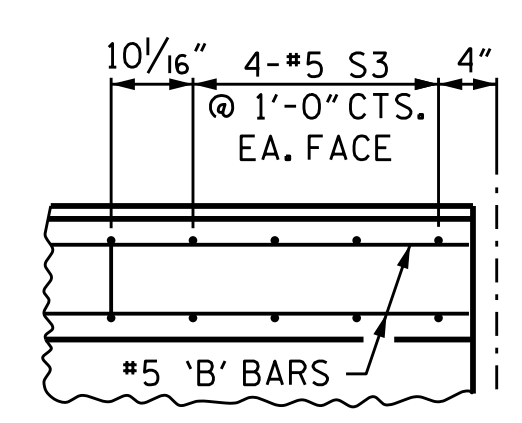

DETAIL 'C'

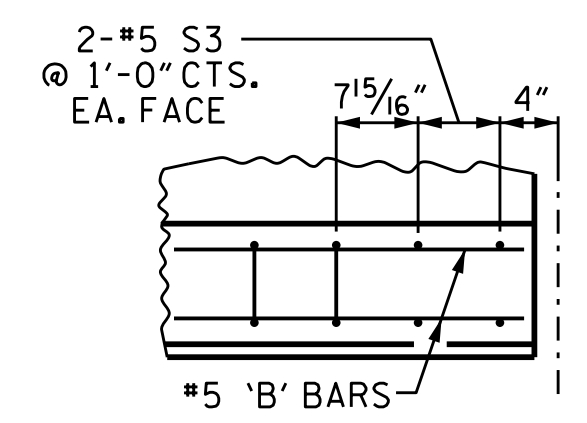

DETAIL 'D'

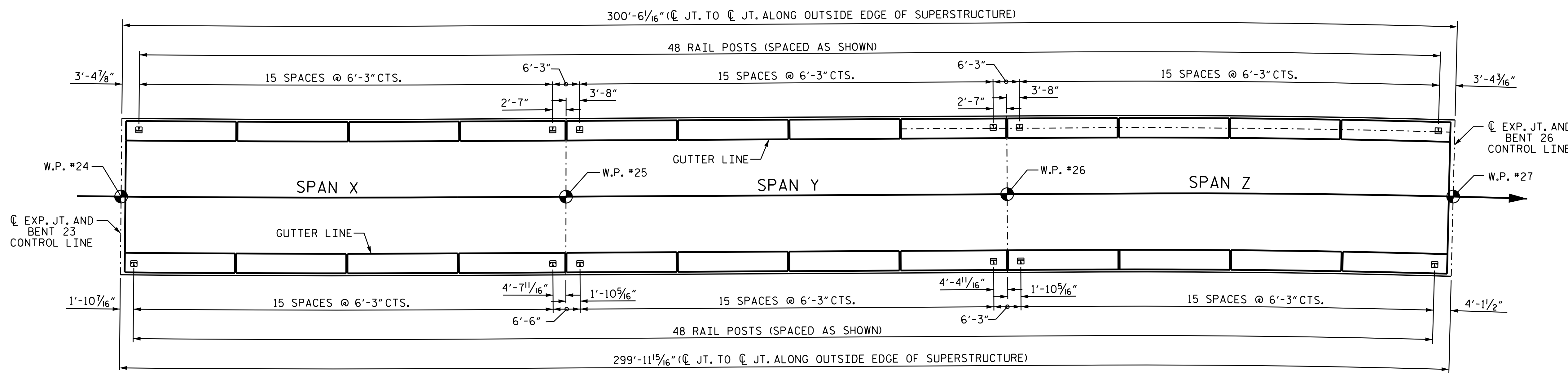

SPAN X, Y AND Z  
PLAN OF RAIL POST SPACINGS

ALL DIMENSIONS ARE TAKEN ALONG THE ARC OF THE OUTSIDE EDGE OF SUPERSTRUCTURE

PROJECT NO. B-4863  
CARTERET COUNTY  
STATION: 34+75.00 -L-

SHEET 9 OF 14

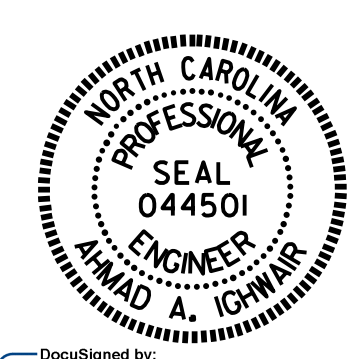

DocuSigned by:  
Ahmad Ighwair  
4894B044C555489  
3/9/2020

DRAWN BY : B. N. BARODAWALA DATE : 05-18  
CHECKED BY : M.A. ALLEN DATE : 11-18  
DESIGN ENGINEER OF RECORD: A. A. IGHWAIR DATE : 04-19

DOCUMENT NOT CONSIDERED FINAL UNLESS ALL SIGNATURES COMPLETED

REVISIONS						SHEET NO.	
NO.	BY:	DATE:	NO.	BY:	DATE:	S1-109	
1			3			TOTAL SHEETS 194	
2			4				