

SPAN M, N AND O

PLAN OF PARAPET

FOR DETAILS OF PARAPET, ENDOPOSTS, AND ADDITIONAL REINFORCEMENT, SEE SHEET 14 OF 14. ALL DIMENSIONS ARE TAKEN ALONG THE ARC OF THE OUTSIDE EDGE OF SUPERSTRUCTURE

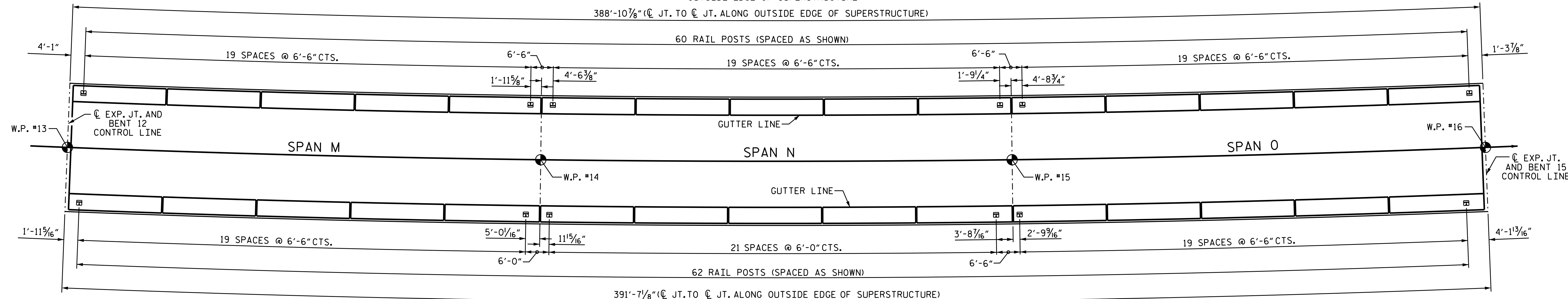

SPAN M, N AND O

PLAN OF RAIL POST SPACINGS

ALL DIMENSIONS ARE TAKEN ALONG THE ARC OF THE OUTSIDE EDGE OF SUPERSTRUCTURE

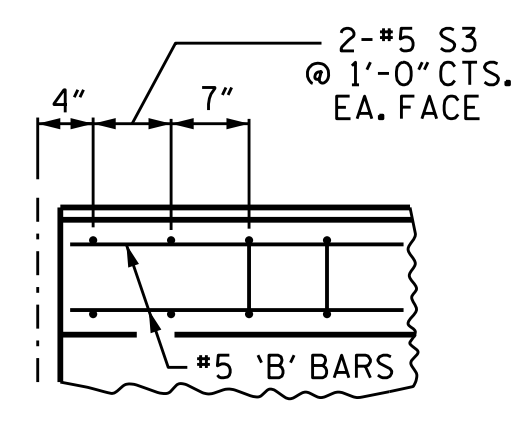

DETAIL 'A'

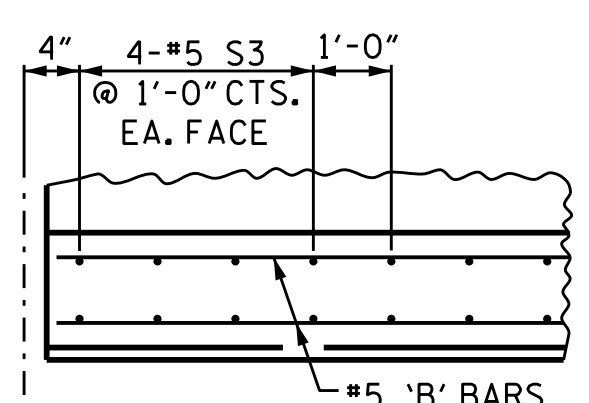

DETAIL 'B'

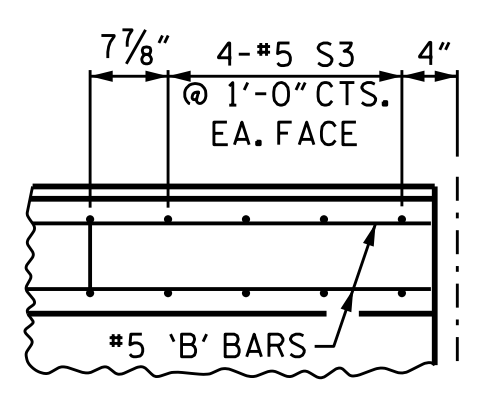

DETAIL 'C'

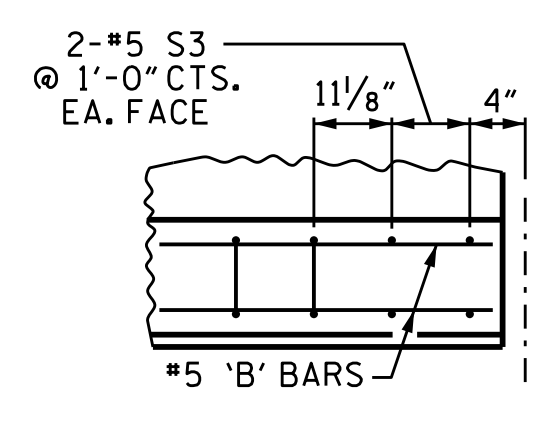

DETAIL 'D'

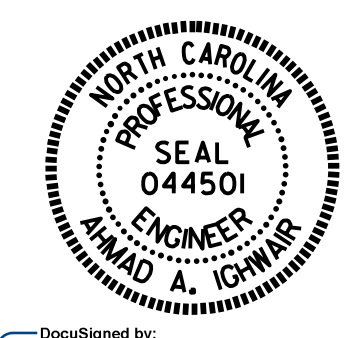

Documented by:
Ahmad Engineer
48848044C5554889
3/9/2020

PROJECT NO. B-4863
CARTERET COUNTY
 STATION: 34+75.00 -L-

SHEET 5 OF 14

STATE OF NORTH CAROLINA
 DEPARTMENT OF TRANSPORTATION
 RALEIGH
 CONCRETE PARAPET
 DETAILS AND
 2 BAR METAL RAIL
 POST SPACING

DRAWN BY : B. N. BARODAWALA DATE : 05-18
 CHECKED BY : M.A. ALLEN DATE : 11-18
 DESIGN ENGINEER OF RECORD: A. A. IGHWAIR DATE : 04-19

DOCUMENT NOT CONSIDERED
 FINAL UNLESS ALL
 SIGNATURES COMPLETED

REVISIONS						SHEET NO.	
NO.	BY:	DATE:	NO.	BY:	DATE:	S1-105	
1			3			TOTAL SHEETS	194
2			4				