

LOAD AND RESISTANCE FACTOR RATING (LRFR) SUMMARY FOR PRESTRESSED CONCRETE GIRDERS

LOAD FACTORS:

DESIGN LOAD RATING FACTORS	LIMIT STATE	γ_{DC}	γ_{DW}
	STRENGTH I	1.25	1.50
	SERVICE III	1.00	1.00

NOTES:

MINIMUM RATING FACTORS ARE BASED ON THE STRENGTH I AND SERVICE III LIMIT STATES.
ALLOWABLE STRESSES FOR SERVICE III LIMIT STATE ARE AS REQUIRED FOR DESIGN.

LEVEL	VEHICLE	WEIGHT (W) (TONS)	CONTROLLING LOAD RATING #	MINIMUM RATING FACTORS (RF)	TONS = W x RF	STRENGTH I LIMIT STATE										SERVICE III LIMIT STATE										COMMENT NUMBER
						MOMENT					SHEAR					MOMENT										
						LIVE-LOAD FACTORS (γ_{LL})	DISTRIBUTION FACTORS (DF)	RATING FACTOR	SPAN	GIRDER LOCATION	DISTANCE FROM LEFT END OF SPAN (ft)	DISTRIBUTION FACTORS (DF)	RATING FACTOR	SPAN	GIRDER LOCATION	DISTANCE FROM LEFT END OF SPAN (ft)	LIVE-LOAD FACTORS (γ_{LL})	DISTRIBUTION FACTORS (DF)	RATING FACTOR	SPAN	GIRDER LOCATION	DISTANCE FROM LEFT END OF SPAN (ft)				
DESIGN LOAD RATING	HL-93 (INVENTORY)	N/A	①	1.06	--	1.75	0.937	1.06	0	ER	64.49	0.937	1.46	0	ER	51.59	0.80	0.937	1.15	0	ER	64.49				
	HL-93 (OPERATING)	N/A		1.37	--	1.35	0.937	1.37	0	ER	64.49	0.937	1.89	0	ER	51.59	N/A	--	--	--	--	--				
	HS-20 (INVENTORY)	36.000	②	1.58	56.71	1.75	0.937	1.58	0	ER	64.49	0.937	1.88	0	ER	51.59	0.80	0.937	1.71	0	ER	64.49				
	HS-20 (OPERATING)	36.000		2.04	75.51	1.35	0.937	2.04	0	ER	64.49	0.937	2.44	0	ER	51.59	N/A	--	--	--	--	--				
LEGAL LOAD RATING	SINGLE VEHICLE (SV)	SNSH	13.500		4.18	56.46	1.40	0.937	4.81	0	ER	64.49	0.937	5.59	0	ER	51.59	0.80	0.937	4.18	0	ER	64.49			
		SNGARBS2	20.000		2.97	59.41	1.40	0.937	3.41	0	ER	64.49	0.937	4.07	0	ER	51.59	0.80	0.937	2.97	0	ER	64.49			
		SNAGRIS2	22.000		2.76	60.61	1.40	0.937	3.17	0	ER	64.49	0.937	3.73	0	ER	51.59	0.80	0.937	2.76	0	ER	64.49			
		SNCOTTS3	27.250		2.08	56.62	1.40	0.937	2.39	0	ER	64.49	0.937	2.98	0	ER	51.59	0.80	0.937	2.08	0	ER	64.49			
		SNAGGRS4	34.925		1.68	58.71	1.40	0.937	1.93	0	ER	64.49	0.937	2.42	0	ER	51.59	0.80	0.937	1.68	0	ER	64.49			
		SNS5A	35.550		1.65	58.60	1.40	0.937	1.89	0	ER	64.49	0.937	2.49	0	ER	51.59	0.80	0.937	1.65	0	ER	64.49			
		SNS6A	39.950		1.49	59.53	1.40	0.937	1.71	0	ER	64.49	0.937	2.18	0	ER	51.59	0.80	0.939	1.49	0	ER	64.49			
		SNS7B	42.000		1.42	59.58	1.40	0.937	1.63	0	ER	64.49	0.937	2.18	0	ER	51.59	0.80	0.937	1.42	0	ER	64.49			
	TRUCK TRACTOR SEMI-TRAILER (TTST)	TNAGRIT3	33.000		1.81	59.76	1.40	0.937	2.08	0	ER	64.49	0.937	2.56	0	ER	51.59	0.80	0.937	1.81	0	ER	64.49			
		TNT4A	33.075		1.81	59.93	1.40	0.937	2.08	0	ER	64.49	0.937	2.63	0	ER	51.59	0.80	0.937	1.81	0	ER	64.49			
		TNT6A	41.600		1.46	60.84	1.40	0.937	1.68	0	ER	64.49	0.937	2.24	0	ER	51.59	0.80	0.937	1.46	0	ER	64.49			
		TNT7A	42.000		1.46	61.26	1.40	0.937	1.68	0	ER	64.49	0.939	2.29	0	ER	51.59	0.80	0.937	1.46	0	ER	64.49			
		TNT7B	42.000		1.48	62.18	1.40	0.937	1.70	0	ER	64.49	0.937	2.18	0	ER	51.59	0.80	0.937	1.48	0	ER	64.49			
		TNAGRIT4	43.000		1.43	61.50	1.40	0.937	1.64	0	ER	64.49	0.937	2.03	0	ER	51.59	0.80	0.937	1.43	0	ER	64.49			
TNAGT5A	45.000		1.36	61.12	1.40	0.937	1.56	0	ER	64.49	0.937	1.95	0	ER	51.59	0.80	0.937	1.36	0	ER	64.49					
TNAGT5B	45.000		③	1.35	60.70	1.40	0.937	1.55	0	ER	64.49	0.937	1.95	0	ER	51.59	0.80	0.937	1.35	0	ER	64.49				

SECTION PROPERTIES 72" CFRP F.I.B.

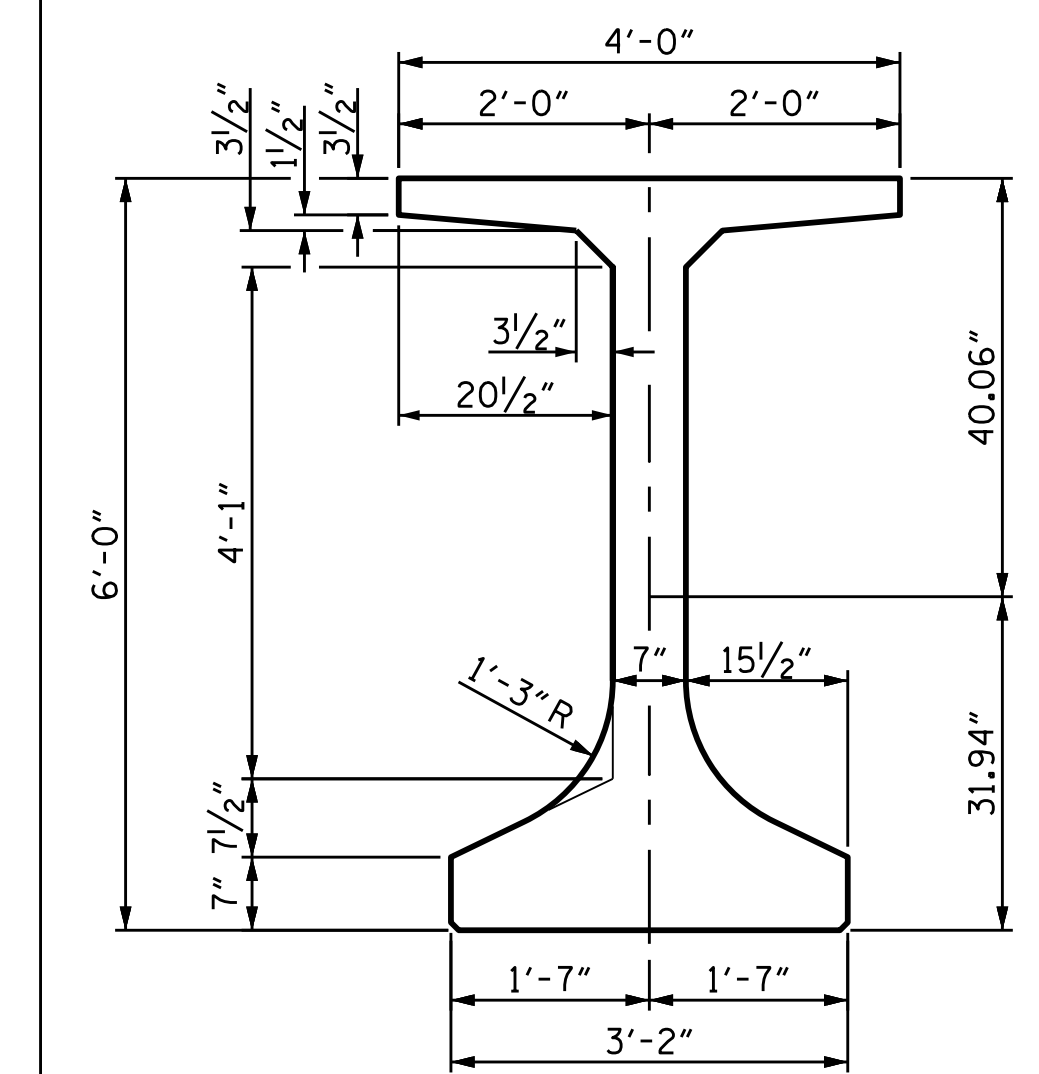

AREA = 1058.6 SQ. IN. = 7.3512 SQ. FT.
WEIGHT = 7.3512 x 150 = 1102.7 LBS./FT.
 $I_{XX} = 740,416 \text{ IN.}^4$ $I_{YY} = 82,099 \text{ IN.}^4$
 $C_T = 40.06 \text{ IN.}$ $C_B = 31.94 \text{ IN.}$
 $S_T = 18,483 \text{ IN.}^3$ $S_B = 23,182 \text{ IN.}^3$

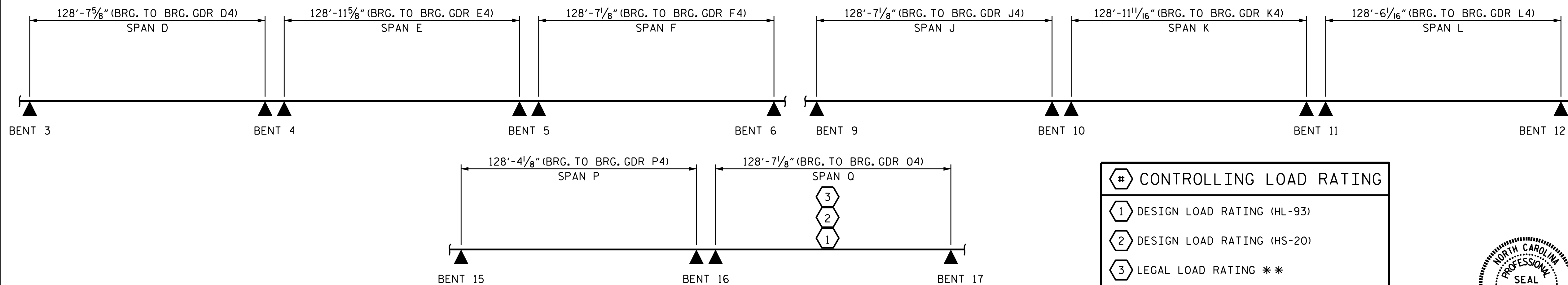

PROJECT NO. B-4863
CARTERET COUNTY
STATION: 34+75.00 -L-

SHEET 2 OF 5

STATE OF NORTH CAROLINA
DEPARTMENT OF TRANSPORTATION
RALEIGH
LRFR SUMMARY
72" CFRP F.I.B
PRESTRESSED CONCRETE GIRDERS
(GFRP STIRRUP OPTION)
SPANS D, E, F, J, K, L, P & Q

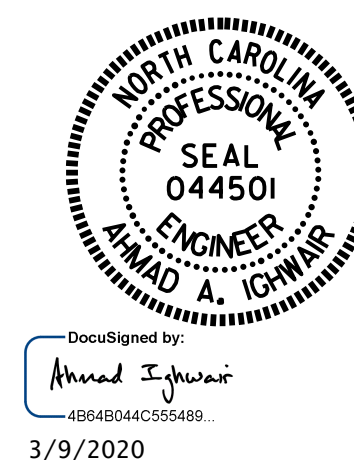

DOCUMENT NOT CONSIDERED FINAL UNLESS ALL SIGNATURES COMPLETED

REVISIONS						SHEET NO.	
NO.	BY:	DATE:	NO.	BY:	DATE:	S1-025	
1			3			TOTAL SHEETS	194
2			4				

ASSEMBLED BY : S. M. MATTA	DATE : 12/19
CHECKED BY : A. A. ICHWAIR	DATE : 12/19
DRAWN BY : MAA	1/08
CHECKED BY : GM/DI	2/08
REV. 11/12/08RR	MAA/GM
REV. 10/1/11	MAA/GM
REV. 12/17	MAA/THC