

STATE	PROJECT NO.	SHEET NO.	TOTAL SHEETS
N.C.	I-5905	18	
WBS NO. 45888.3.GVI			

PAVEMENT SCHEDULE	
A1	PROP. 11" PORTLAND CEMENT CONCRETE PAVEMENT
B1	PROP. APPROX. 5/8" ULTRA-THIN BONDED WEARING COURSE, AT AN AVERAGE RATE OF 70 LBS. PER SQ. YD.
C1	PROP. APPROX. 2.0" ASPHALT CONCRETE SURFACE COURSE, TYPE S9.5D, AT AN AVERAGE RATE OF 224 LBS. PER SQ. YD.
C2	PROP. APPROX. 1.5" ASPHALT CONCRETE SURFACE COURSE, TYPE S9.5D, AT AN AVERAGE RATE OF 168 LBS. PER SQ. YD.
C3	PROP. APPROX. 3.0" ASPHALT CONCRETE SURFACE COURSE, TYPE S9.5D, IN 2 SEPARATE 1.5" LIFTS AT AN AVERAGE RATE OF 168 LBS. PER SQ. YD.
D1	PROP. APPROX. 4.0" ASPHALT CONCRETE INTERMEDIATE COURSE, TYPE I19.0C, AT AN AVERAGE RATE OF 456 LBS. PER SQ. YD.
E1	PROP. APPROX. 4.0" ASPHALT CONCRETE BASE COURSE, B25.0C, AT AN AVERAGE RATE OF 456 LBS. PER SQ. YD.
E2	PROP. APPROX. 8.0" ASPHALT CONCRETE BASE COURSE, TYPE B25.0C, IN 2 SEPARATE 4" LIFTS AT AN AVERAGE RATE OF 456 LBS. PER SQ. YD.
R1	PROP. 2'6" CONCRETE CURB AND GUTTER 11" THICK
T	SHOULDER CONSTRUCTION
U	EXISTING PAVEMENT
V2	MILLING 1.5" DEPTH
V3	MILLING, 2.0" DEPTH
Y	MILLED RUMBLE STRIPS
Z	EXISTING STABILIZED SUBGRADE

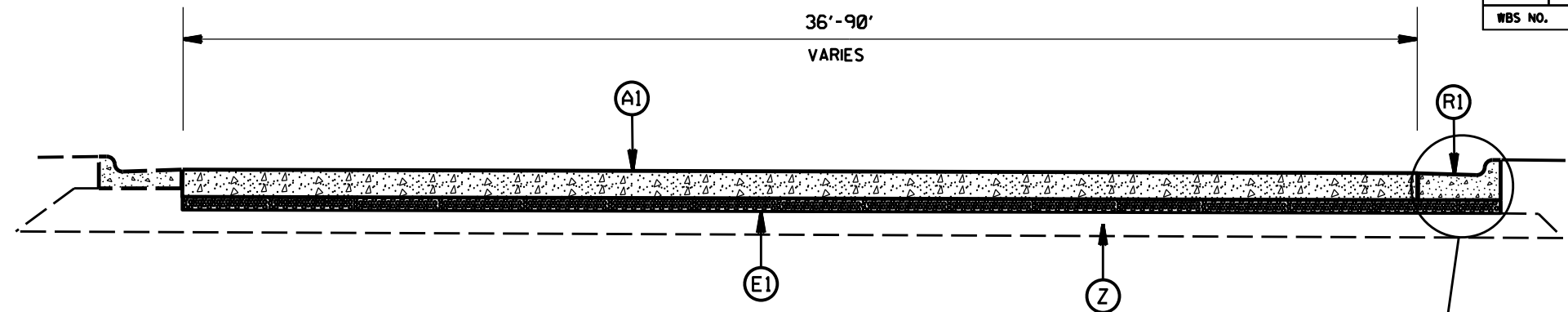

TYPICAL SECTION NO.21
OFF RAMP TO STATESVILLE AVE

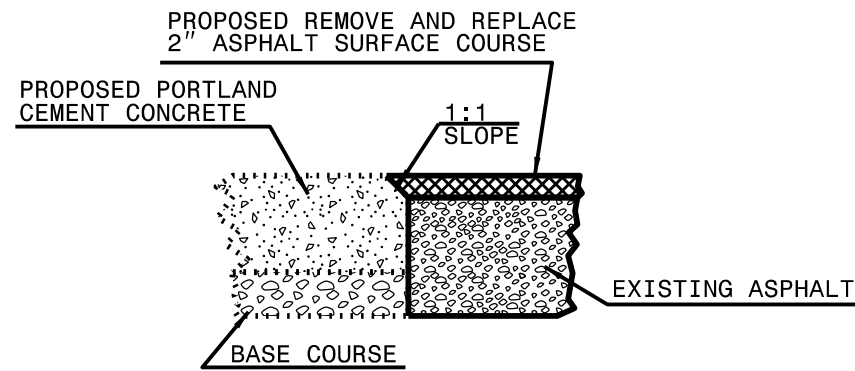

LONGITUDINAL JOINT

PROPOSED PORTLAND CEMENT CONCRETE
TO
PROPOSED ASPHALT SURFACE COURSE

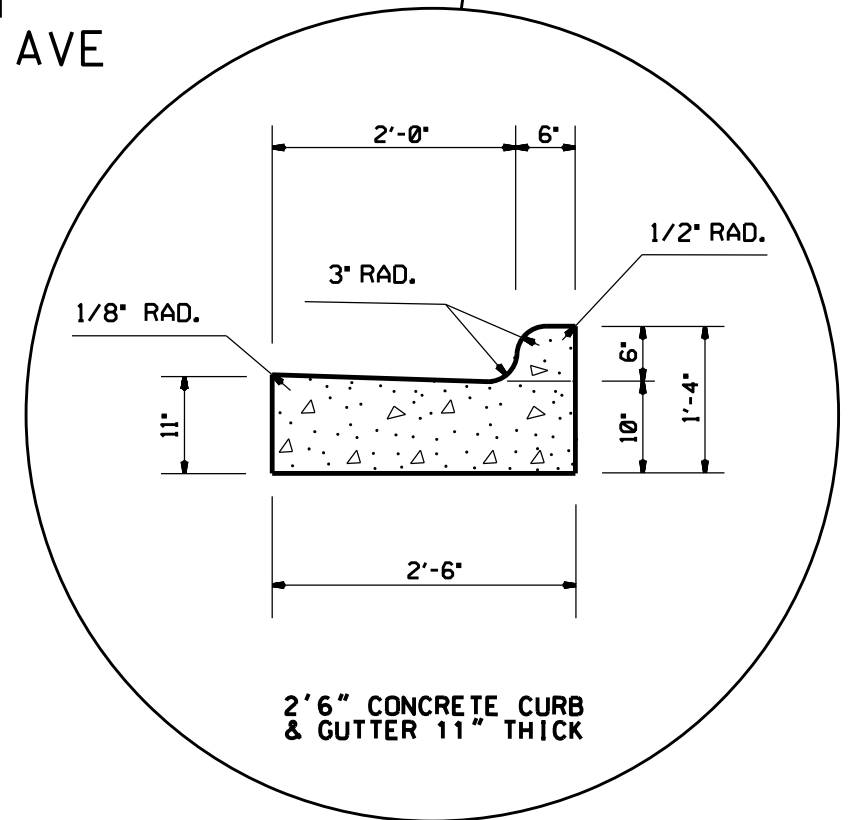

2'6" CONCRETE CURB
& GUTTER 11" THICK

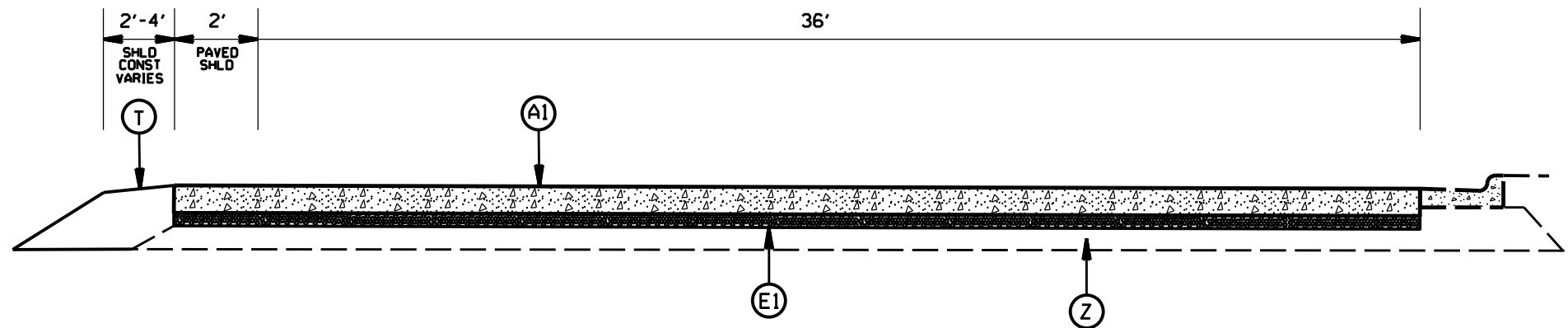

TYPICAL SECTION NO.22
TO RAMP TO STATESVILLE AVE

I-5905
I-85 PAVEMENT PRESERVATION
MECKLENBURG COUNTY

SCALE	-NA-		REVISIONS
DATE	3/19		
DWG. BY	JHE		
DESIGN BY	JHE		
APPROVED			