

DETAIL "A"

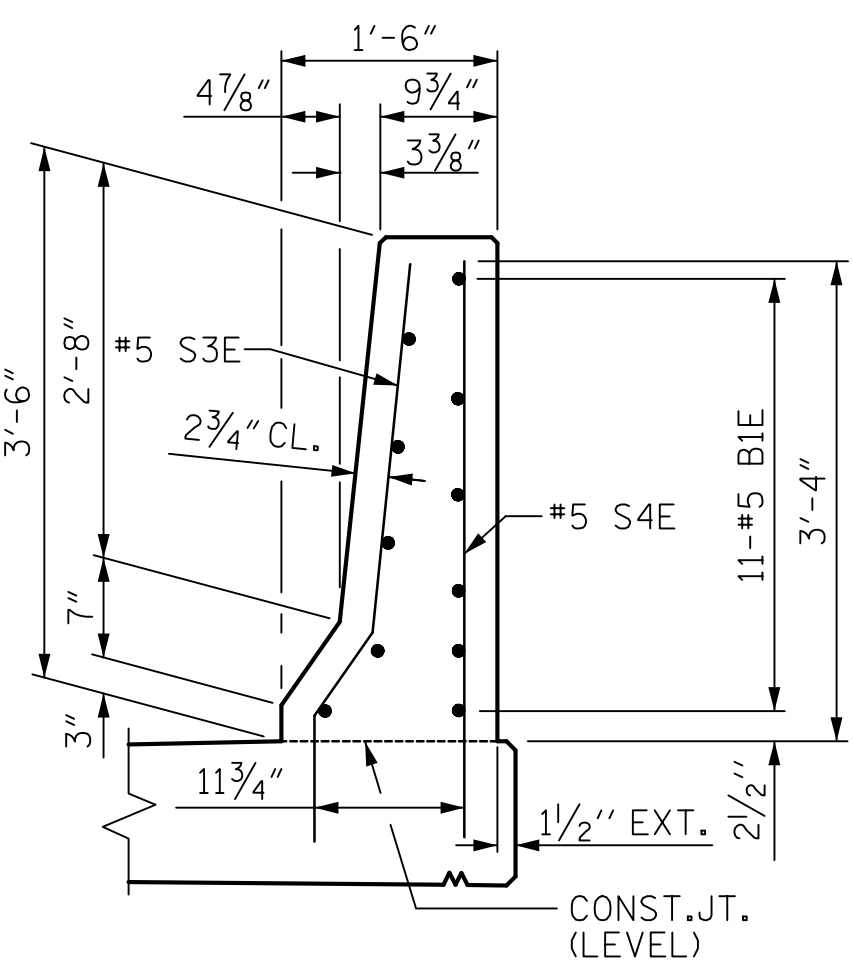

SECTION A-A

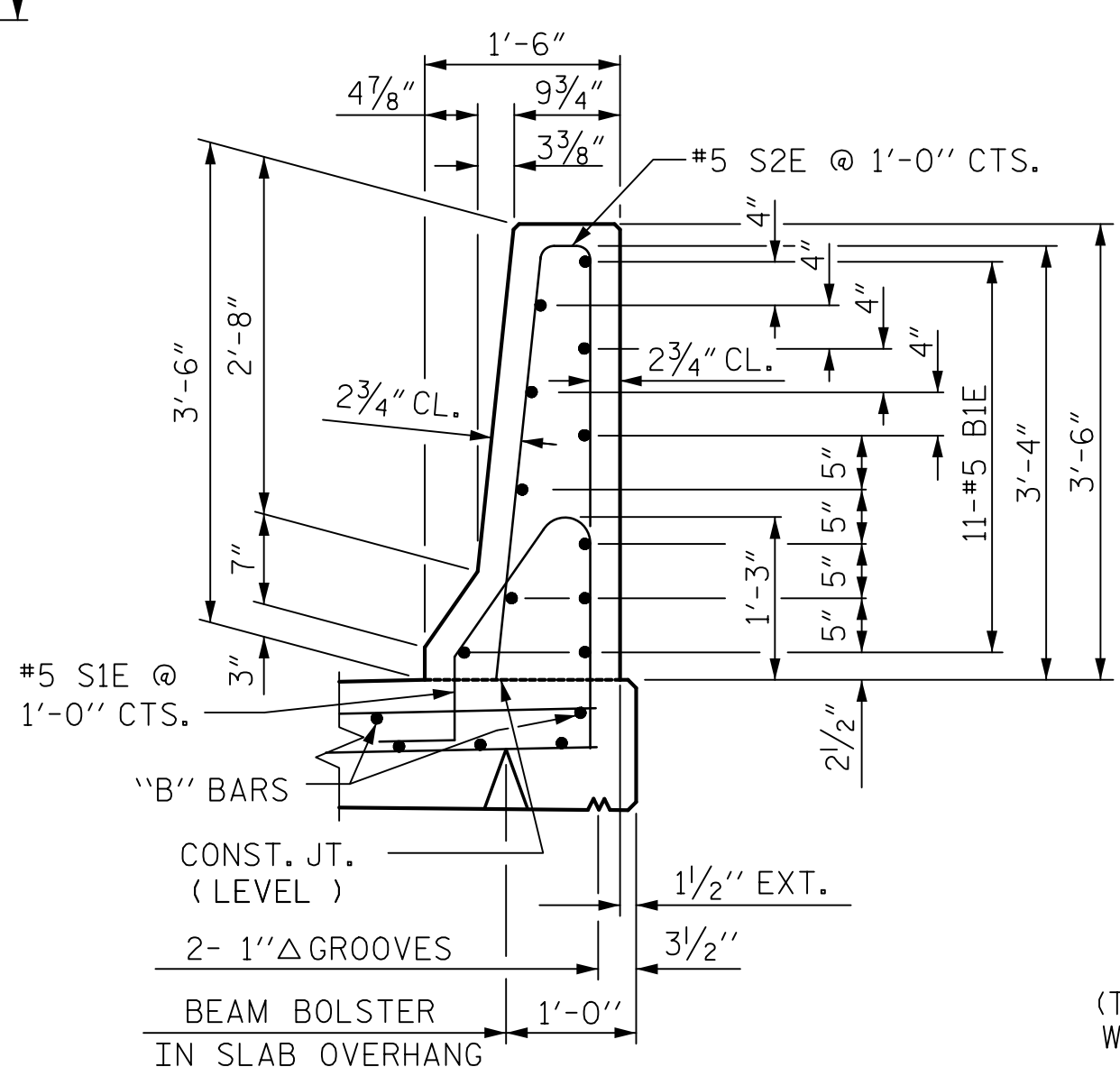

SECTION THRU RAIL

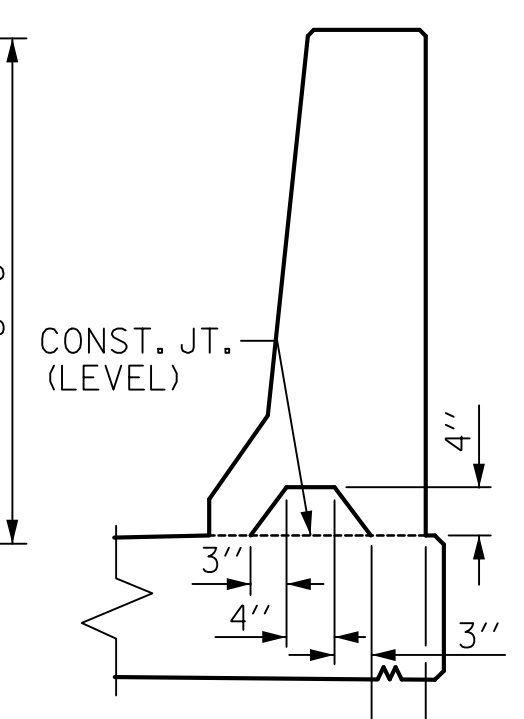

SECTION S-S
AT DAM IN OPEN JOINT
(THIS IS TO BE USED ONLY WHEN SLIP FORM IS USED)

NOTES

THE BARRIER RAIL IN EACH SPAN SHALL NOT BE CAST UNTIL ALL SLAB CONCRETE IN THAT SPAN HAS BEEN CAST AND HAS REACHED A MINIMUM COMPRESSIVE STRENGTH OF 3,000 PSI.

WHEN FOAM JOINT SEAL IS REQUIRED, THE JOINT IN THE DECK SHALL BE SAWED PRIOR TO THE CASTING OF BARRIER RAIL.

ALL REINFORCING STEEL IN BARRIER RAILS SHALL BE EPOXY COATED.

THE #5 S3E AND S4E BARS SHALL BE INSTALLED, USING AN ADHESIVE ANCHORING SYSTEM, AFTER SAWING THE JOINT. THE YIELD LOAD FOR THE #5 S3E AND S4E BARS IS 18.6 KIPS. FIELD TESTING FOR THE ADHESIVE BONDING SYSTEM IS NOT REQUIRED.

GROOVED CONTRACTION JOINTS, 1/2" IN DEPTH, SHALL BE TOOLED IN ALL EXPOSED FACES OF THE BARRIER RAIL AND IN ACCORDANCE WITH ARTICLE 825-10(B) OF THE STANDARD SPECIFICATIONS. THE CONTRACTION JOINT SHALL BE LOCATED AT EACH THIRD POINT BETWEEN BARRIER RAIL EXPANSION JOINTS. ONLY ONE CONTRACTION JOINT IS REQUIRED AT MIDPOINT OF BARRIER RAIL SEGMENTS LESS THAN 20 FEET IN LENGTH AND NO CONTRACTION JOINTS ARE REQUIRED FOR THOSE SEGMENTS LESS THAN 10 FEET IN LENGTH.

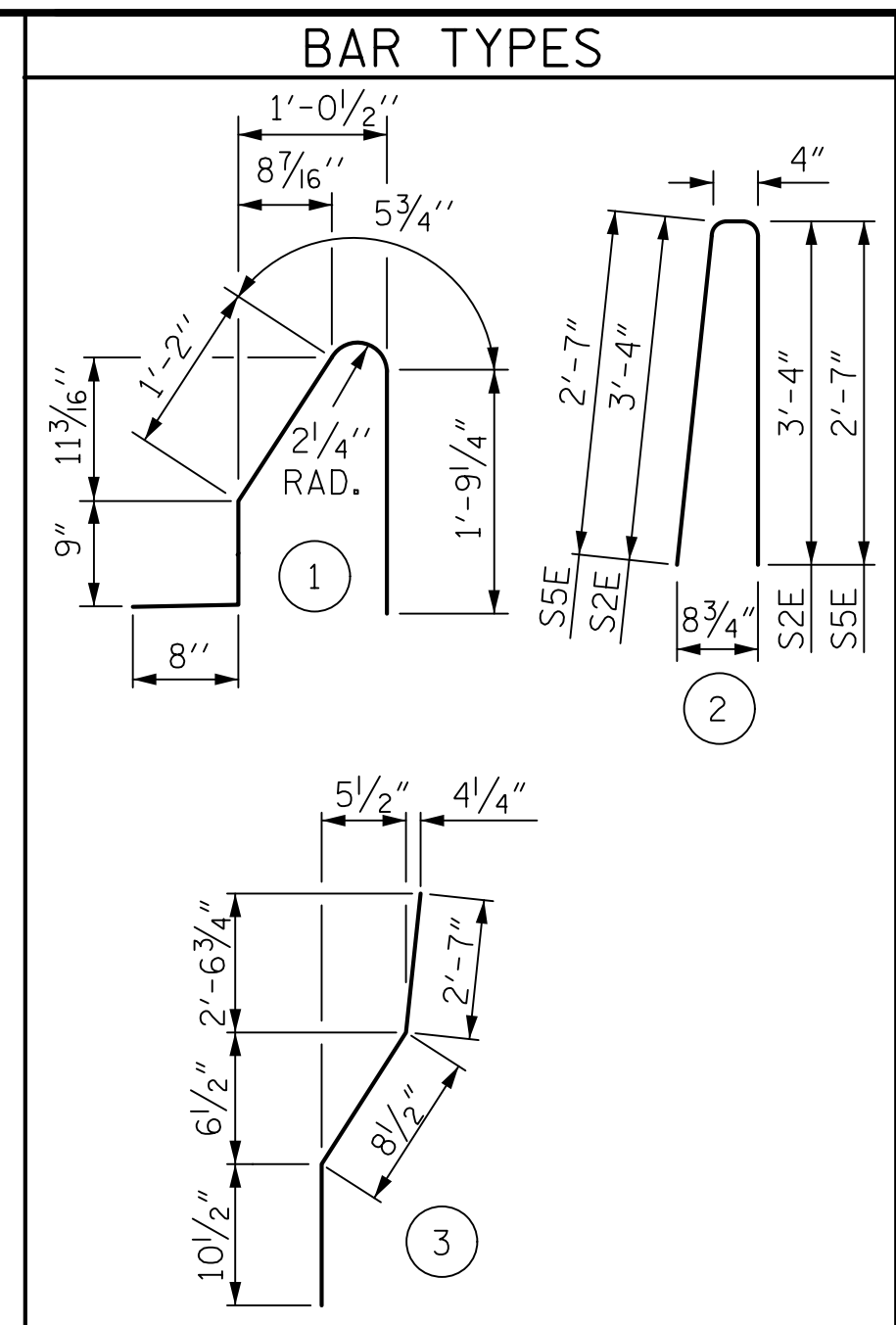

ALL BAR DIMENSIONS ARE OUT TO OUT

BILL OF MATERIAL
FOR CONCRETE BARRIER RAIL ONLY

BAR	NO.	SIZE	TYPE	LENGTH	WEIGHT
B1E	440	#5	STR	22'-7"	10364
S1E	944	#5	1	4'-10"	4759
S2E	936	#5	2	7'-0"	6834
S3E	16	#5	3	4'-2"	70
S4E	16	#5	STR	4'-0"	67
S5E	8	#5	2	5'-6"	46

EPOXY COATED REINFORCING STEEL 22,140 LBS.
CLASS AA CONCRETE 124.8 CU. YDS.
CONCRETE BARRIER RAIL 919.5 LIN. FT.

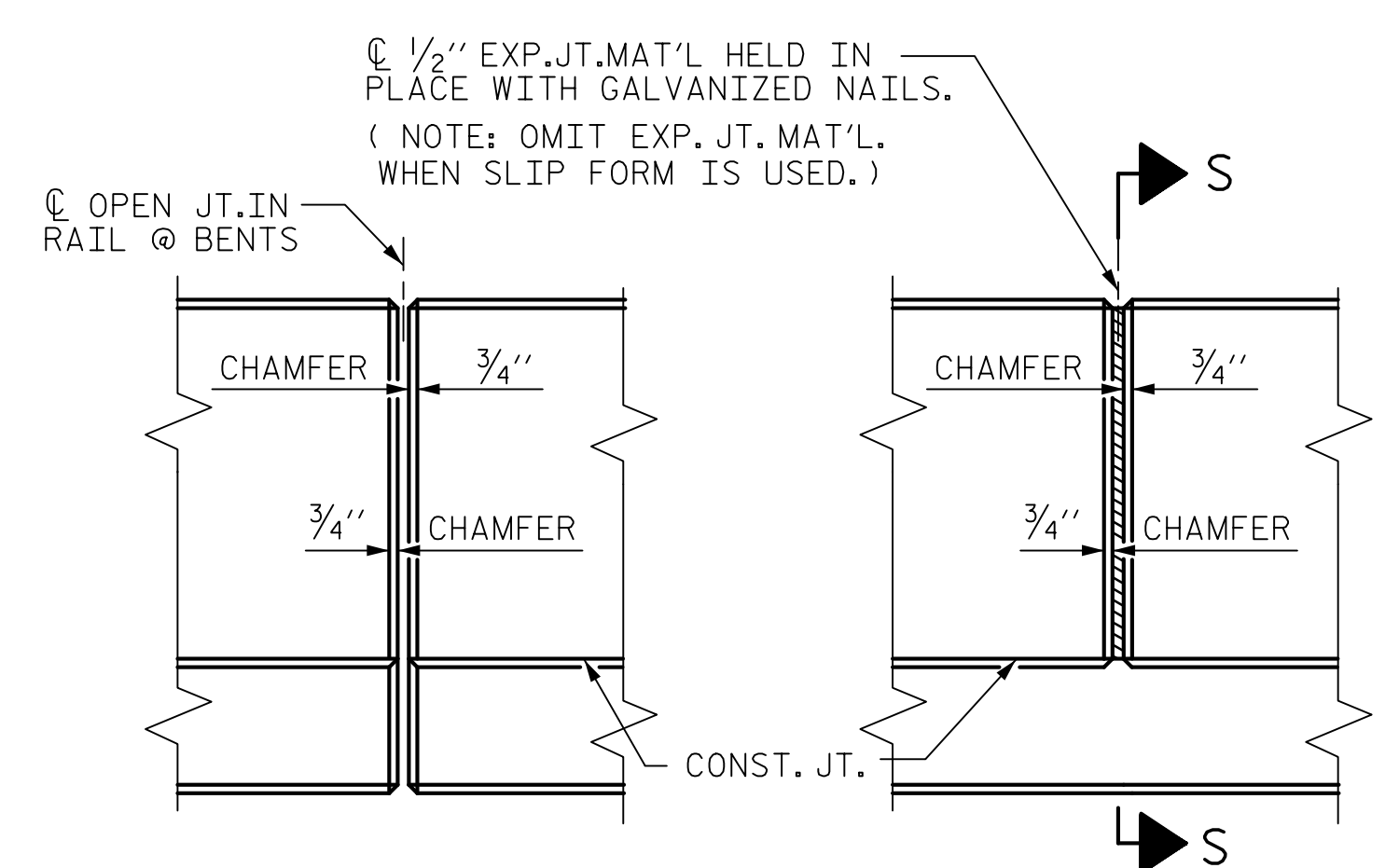

ELEVATION AT EXPANSION JOINTS
BARRIER RAIL DETAILS

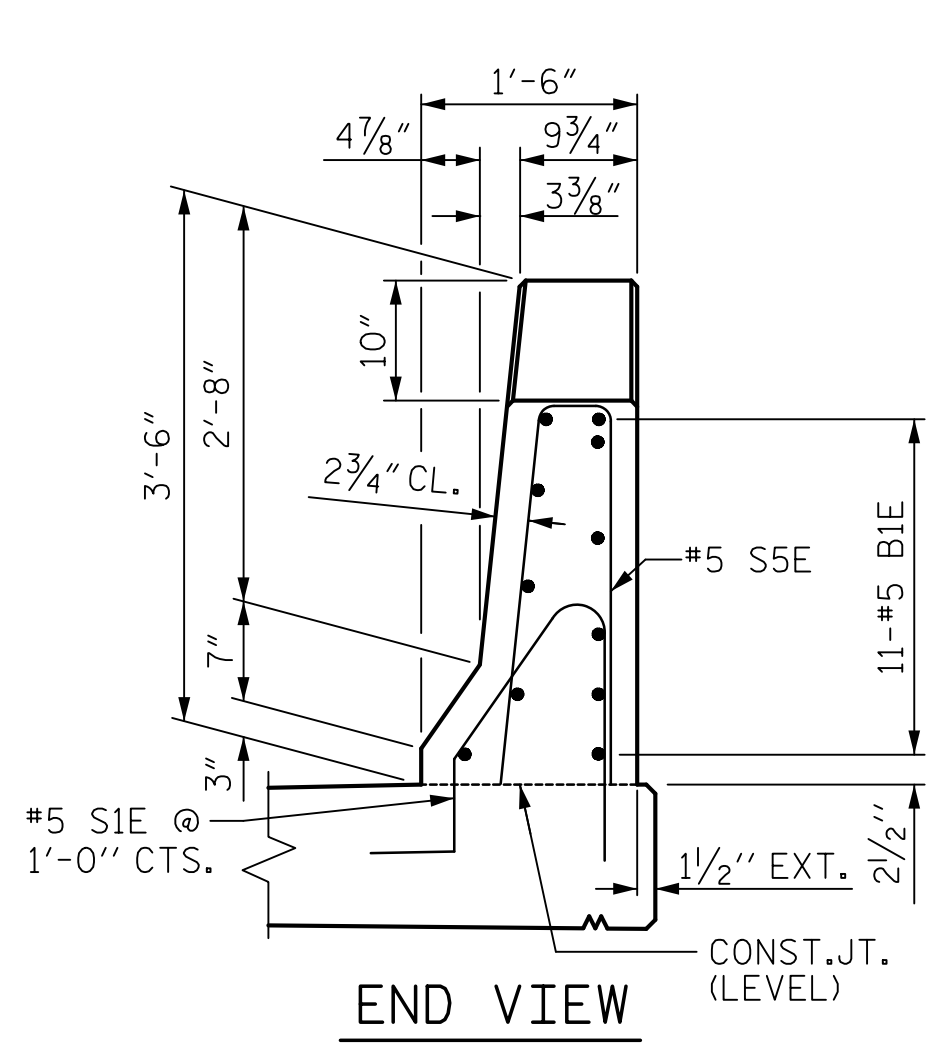

END VIEW

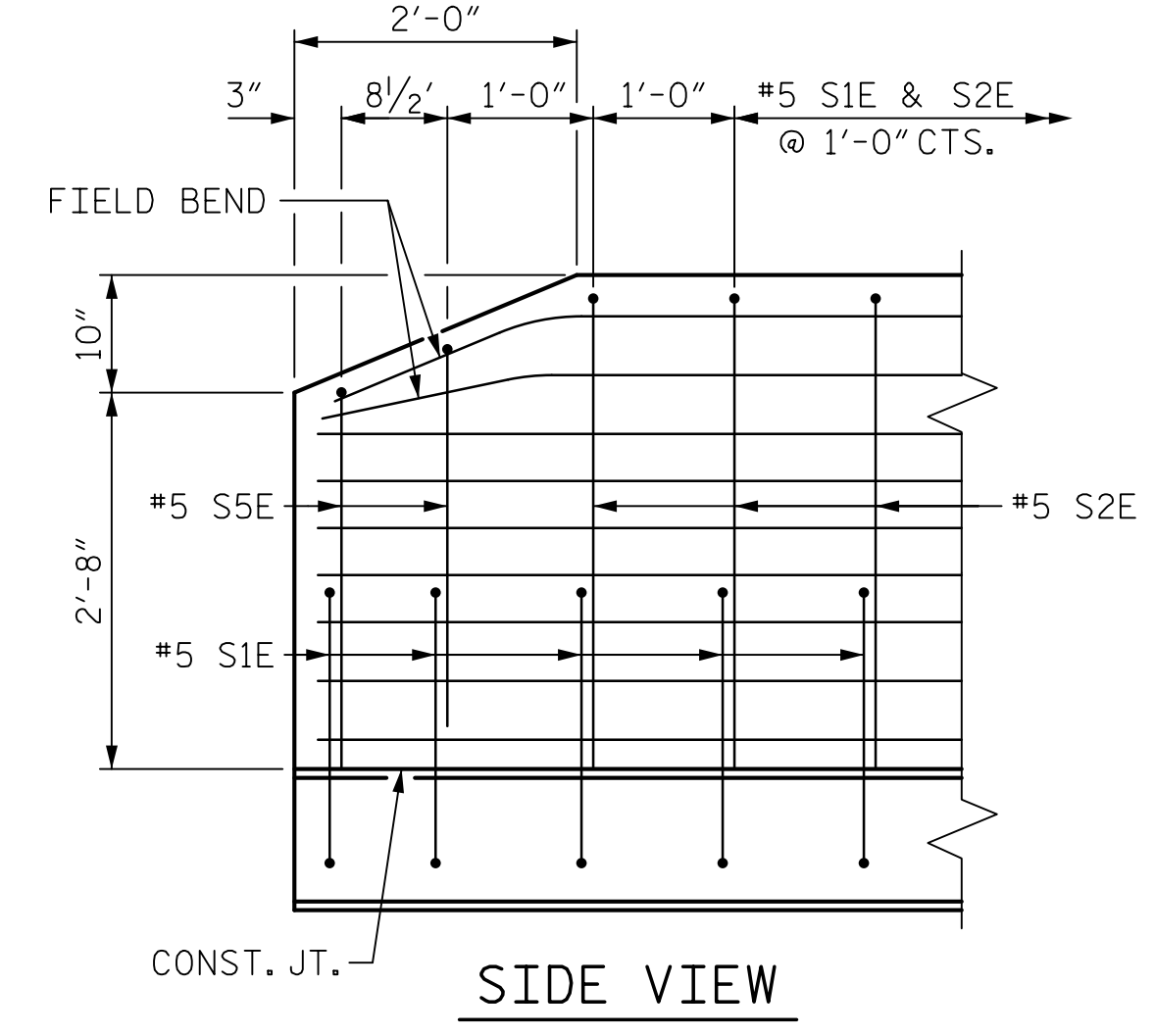

SIDE VIEW

END OF RAIL DETAILS

Mead & Hunt
111 E. Hargett Street
Suite 300
Raleigh, NC 27601
919-714-8670
meadhunt.com
NC License No. F-1235



PROJECT NO. B-5619
LENOIR COUNTY
STATION: 30+80.00 -L-
SHEET 2 OF 2

STATE OF NORTH CAROLINA
DEPARTMENT OF TRANSPORTATION
RALEIGH
STANDARD
CONCRETE BARRIER RAIL

ASSEMBLED BY : J.S. HOBSON DATE : 12/11/20
CHECKED BY : J.A. BOYER DATE : 12/19/20
DRAWN BY : ARB 5/87 REV. 7/12 MAA/GM
CHECKED BY : SJD 9/87 REV. 6/13 MAA/GM
REV. 12/17 MAA/THC

DOCUMENT NOT CONSIDERED FINAL UNLESS ALL SIGNATURES COMPLETED

REVISIONS

NO.	BY:	DATE:	NO.	BY:	DATE:
1			3		
2			4		

SHEET NO. S1-22
TOTAL SHEETS 40