

PLAN

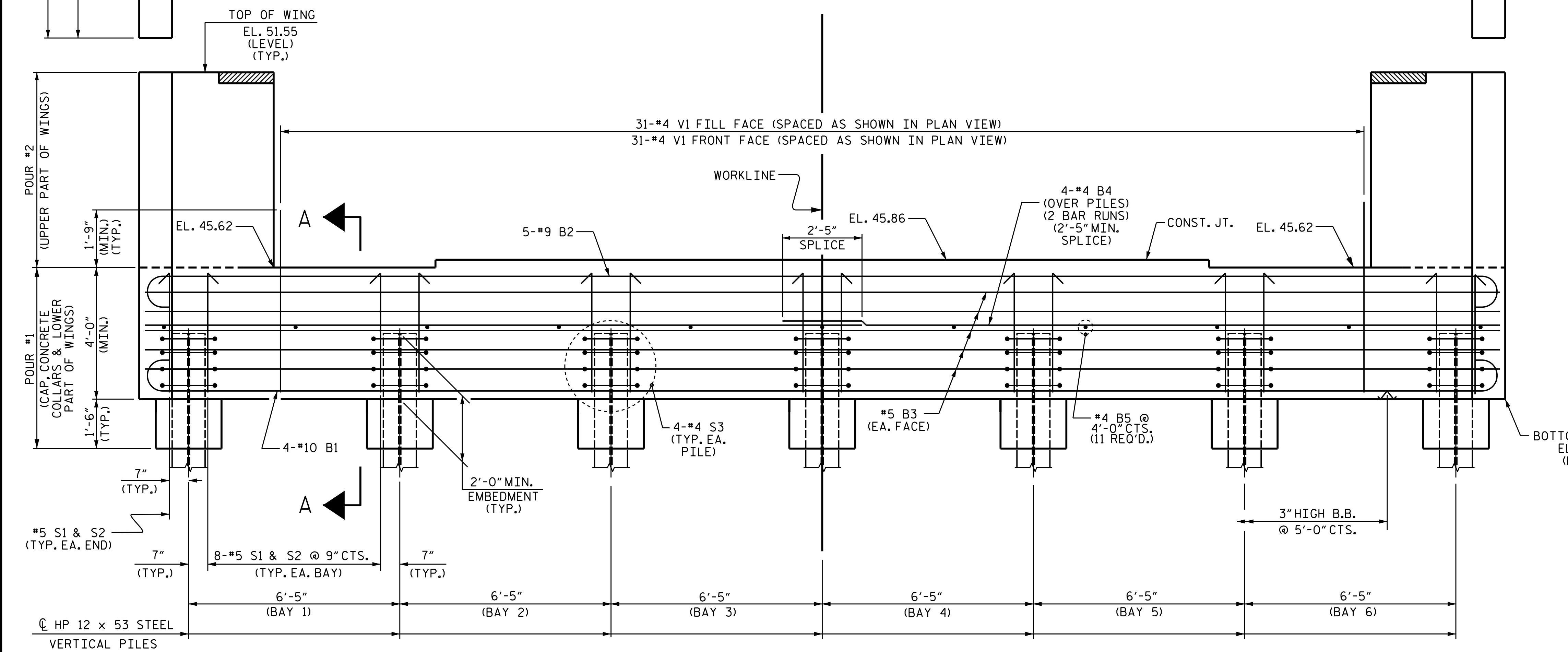

ELEVATION

NOTES

STIRRUPS IN CAP MAY BE SHIFTED AS NECESSARY TO CLEAR #4 V1 BARS.
 THE TOP SURFACE OF POUR #1 OF THE END BENT CAP AND WINGS, EXCLUDING THE BEARING AREA AND NON-INTEGRAL AREA AT THE ENDS OF CAP, SHALL BE RAKED TO A DEPTH OF 1/4".
 THE UPPER PORTION OF THE INTEGRAL END BENT SHALL BE POURED WITH THE SUPERSTRUCTURE. SEE SUPERSTRUCTURE PLANS.

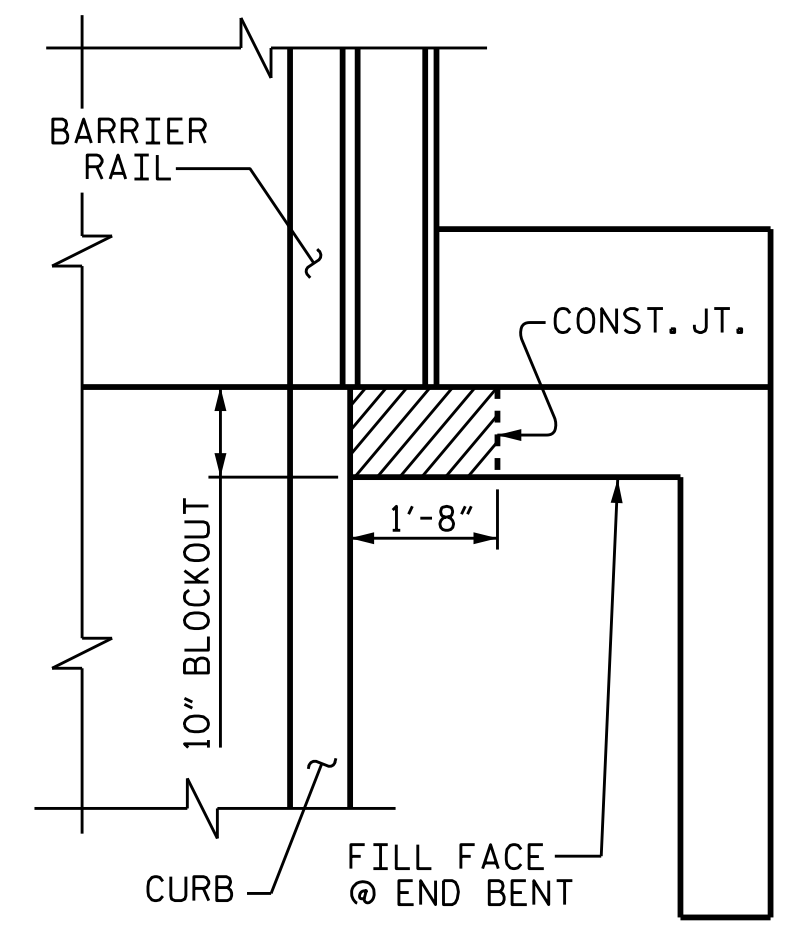

PLAN

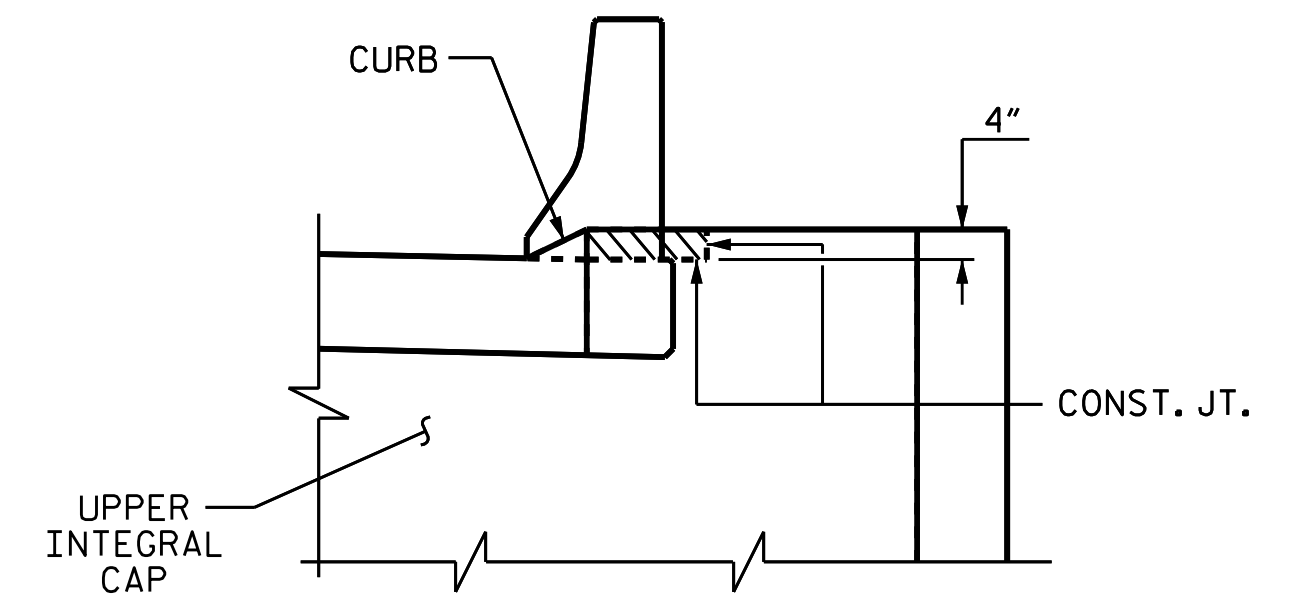

ELEVATION

BLOCKOUT IN WING WALL

THE CONCRETE IN THE SHADED AREA OF THE WING SHALL BE POURED AFTER THE BARRIER RAIL IS CAST IF SLIP FORMING IS USED.

PROJECT NO. B-4931
 EDGEcombe COUNTY
 STATION: 16+99.00 -L-

SHEET 1 OF 3

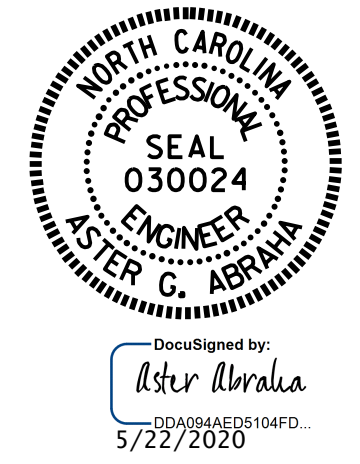

STATE OF NORTH CAROLINA
 DEPARTMENT OF TRANSPORTATION
 RALEIGH

SUBSTRUCTURE
 INTEGRAL
 END BENT 1

DRAWN BY: M.M. AHMED DATE: 11/19
 CHECKED BY: S. WANCE DATE: 01/20
 DESIGN ENGINEER OF RECORD: M.M. AHMED DATE: 09/19

REVISIONS						SHEET NO.
NO.	BY:	DATE:	NO.	BY:	DATE:	S-19
1			3			TOTAL SHEETS
2			4			30

STR. #1